

RADIO'S GREATEST MAGAZINE

RADIO-CRAFT

Incorporating

**RADIO &
TELEVISION**

HUGO GERNSBACK, Editor



**HAND
RADIOPHONE**
See Page 522

MAY

25¢

CANADA 30¢
1942

OVER 125 ILLUSTRATIONS

Ears of the Signal Corps!



*Serving
the cause
of Victory*

Murdock

**RADIO
PHONES**

For training—for action—the U. S. Army Signal Corps demands sensitive, reliable Radio Phones.

Precision-built Murdock Radio Phones are important aids to communication wherever the Army goes. In peace—in war—since 1904, Murdock has furnished 'scientific ears' for the Signal Corps.

MURDOCK MANUFACTURING COMPANY—Chelsea, Mass.

Certainly -- I Give You Both TRAINING AND EXPERIENCE when I Train You at Home to BE A RADIO TECHNICIAN



LEARN RADIO THOROUGHLY

from My Easy-to-Understand Lesson Texts



Radio Technicians earn good pay, get and hold good jobs, because they KNOW Radio — know the operation of various Radio circuits—know where to look for trouble when it occurs and how to fix it—know how to adjust circuits to perform most efficiently. That's why the background of every capable Radio Technician is a thorough knowledge of Radio theory and practice. My 67 Lesson Texts give you this knowledge in practical, easy-to-understand explanations, accompanied by hundreds of illustrations, diagrams, examples. You learn quickly because my Lessons are prepared especially for study at home—with more than 27 years of experience in home instruction behind them.

BUILD RADIO EQUIPMENT

With Standard Radio Parts and Tubes I Send You



You get, as part of my Course, my 6 Experimental Kits of Radio Parts. They contain more than 100 standard Radio parts, including tubes, condensers, resistors, punched chassis bases, hardware, soldering iron, solder, wire, with which you assemble many Radio receiver, Radio transmitter and other Radio circuits, including Frequency Modulation circuits. You will assemble a superheterodyne receiver and actually test it with a tester which you assemble. This tester is useful in spare time Radio repair and service work while learning. You get Practical Experience assembling and testing these circuits—learn how to identify, wire, install standard Radio parts, to test, align Radio circuits you will encounter on actual work as a Radio Technician. This actual work with Radio parts makes the study of my Course fascinating, and gives you valuable practical experience.

PROVE YOUR KNOWLEDGE

By Tests and Experiments on Equipment You Build



My Special Lesson Texts supplied with my 6 Experimental Kits of Radio Parts show you how to test the performance of the circuits you build and how to use the test equipment in measuring voltage, current, resistance, amplification—how to test and align the circuits for most efficient operation—how to detect troubles in circuits and how to correct them. You learn these facts quickly by actually working with real Radio equipment instead of simply reading books. You get both the knowledge and experience you need to make extra money in spare time while learning—and to fix commercial Radio equipment when you become a Radio technician. Mail the Coupon NOW.

GET ACTUAL EXPERIENCE

And Earn \$5 to \$10 a Week Extra in Spare Time While Learning



I show you how to get and handle Radio service work—how to make \$5, \$10 a week fixing Radio sets in your neighborhood in spare time a few months after enrolling. This gives you practical experience with actual Radios, gives you confidence, helps prepare you for a good full time Radio job. I send you for a good full time Radio job. I send you special "Extra Money Job Sheets" showing you how to do more than 50 Spare Time Radio Jobs. You get these as you progress with my Course and Experiments and gain the knowledge and skill to do actual work. Many men have paid for their Course with spare time money earned this way.

Why More Radio Technicians Now Make \$30, \$40, \$50 a Week Than Ever Before

It takes both Training and Experience to qualify you as a skilled Radio Technician. You get BOTH with my Course. That is why Radio Technicians I trained are cashing in on the booming Radio repair business existing now due to the shortage of new home and auto Radio sets. Keeping the country's 57,400,000 Radios playing, repaired and furnishing new tubes and parts gives good jobs to thousands of part time and full time Radio Technicians; enables many to open their own Radio businesses. N. R. I. Trained Technicians and Operators hold good jobs in many of the country's 832 Broadcasting Stations, and in Aviation, Police, Commercial, Marine and Government Radio, Loud-Speaker Systems give good jobs to many. Others are getting good Civilian Radio jobs with the Government; winning extra rank and pay in the Army, Navy; holding good jobs in factories which are busy making millions of dollars worth of Government Radio Equipment. Because my graduates are thoroughly trained, they will cash in on Radio developments such as Television and "E.M." after the war.

Beginners Quickly Learn to Earn \$5, \$10 a Week Extra Fixing Radios in Spare Time

Nearly every neighborhood offers opportunities for a good part-time Radio Technician to make extra money fixing Radio sets. Because of the growing demand for Radio repairs, these opportunities are increasing rapidly. I train you to take advantage of these opportunities—to make extra money starting a few months after you enroll—to gain valuable experience in practical Radio work.

MAIL THE COUPON—get my Sample Lesson and 64-page Book "Rich Rewards in Radio" NOW. They're FREE. See what Radio offers you as a trained Technician or Operator. Learn how practical my Course really is. Read letters from more than 100 men I have trained so you can see what they are doing, earning. Mail the Coupon NOW—in an envelope or pasted on a penny postal.

J. E. SMITH, President, Dept. 2EX
NATIONAL RADIO INSTITUTE, Washington, D. C.

GET SAMPLE LESSON FREE

MAIL THE COUPON

I want to prove our Course gives practical, money-making information; that it is easy to understand—what you need to master Radio. My Sample Lesson Text, "Radio Receiver Troubles—Their Cause and Remedy," covers a long list of Radio receiver troubles in A.C., D.C., battery, universal, auto, T.R.F., superheterodyne, all-wave and other types of sets. And a cross reference system gives you the probable cause and a quick way to locate and remedy these set troubles. A special section is devoted to receiver check-up, alignment, balancing, neutralizing, testing.



EXTRA PAY IN ARMY, NAVY, TOO

Men likely to go into military service, soldiers, sailors, marines, should mail the Coupon Now! Learning Radio helps men get extra rank, extra prestige, more interesting duty at several times a private's base pay. Also prepares for good Radio jobs after service ends. IT'S SMART TO TRAIN FOR RADIO NOW!

GOOD FOR BOTH 64 PAGE BOOK SAMPLE LESSON FREE

J. E. SMITH, President, National Radio Institute Dept. 2EX, Washington, D. C. without obligating me, mail your Sample Lesson and 64-page Book FREE. I am particularly interested in the branch of Radio checked below. (No salesman will call. Write plainly.)

- | | |
|--|--|
| <input type="checkbox"/> Radio Service Business of My Own | <input type="checkbox"/> Aviation Radio |
| <input type="checkbox"/> Service Technician for Radio Stores and Factories | <input type="checkbox"/> Operating Broadcast- ing Stations |
| <input type="checkbox"/> Spare Time Radio Servicing | <input type="checkbox"/> Army, Navy, Radio Operating Police Radio Stations |
| <input type="checkbox"/> Auto Radio Technician | <input type="checkbox"/> Operating Ship and Harbor Radio |

(If you have not decided which branch you prefer—mail coupon for facts to help you decide.)

Age

Name

Address

City State 14X-1



RADIO-CRAFT

Incorporating

RADIO & TELEVISION

HUGO GERNSBACK
Editor-in-Chief

H. W. SECOR
Managing Editor

G. ALIQUO
Circulation Manager



Contents MAY, 1942 Issue

VOLUME XIII -- NUMBER 9

Mailbag	516
Editorial: A Communications Paradox	Hugo Gernsback 519
The Radio Month in Review	520

RADIO DEFENSE

Hand Radiophone (Front Cover Feature)	H. W. Secor 522
The Radiomen Keeps 'em Flying	E. H. Leftwich 523

SERVICING

"War-Time" Servicing	Willard Moody 524
A Line Voltage-Booster	Lionel Haid 526
What Condenser Ratings Mean	J. W. Straede, B.Sc 528
Servicing Personal Radios in Institutions	Floyd D. Goff 530
RADIO SERVICE DATA SHEET: No. 322. Pilot Model 340 Series	532

SOUND

A Complete P.A. System	Ricardo Muniz, E.E., and Robert J. Bergemann, Jr. 534
Using Theater Sound Systems for "Hearing Aids"	G. R. LaPoint 537
Paper-Disc Sound Recorder	538
Build YOUR OWN Experimental Electronic Organ	W. K. Allan 540
A Modern High-School Sound System	Mahlen Moore 544

ENGINEERING

What Happens in Resonant Circuits?	Willard Moody 546
--	-------------------

EXPERIMENTERS

Constructing a Simple Photo-Electric Cell	Louis Castelli 548
Home-Made Arc Lamp	Joe Nonwicz 550
Automatic Voltage Regulator	S. Gordon Taylor 551

TEST INSTRUMENTS

A Portable U.H.F. Oscillator	George F. Baptiste 554
D.C. Vacuum Tube Voltmeter	Harry S. Bixby 556

FM

Simplified "FM" Receiver Alignment	L. M. Dezettel, W9SFW 557
--	---------------------------

DEPARTMENTS, ETC.

Mailbag	516
The Radio Month in Review	520
Operating Notes	537
Book Reviews	553
RADIO SERVICE DATA SHEETS (See Servicing)	532
Latest Radio Apparatus	560

RADIO & TELEVISION

A.C. Variable Pitch Code Oscillator	J. S. Lee, W8C2P 563
A 2-Band Midget-Tube Receiver	L. M. Dezettel, W9SFW 564
Talking on a Light Beam	James Solms 566
Experimental "Chew-Box" Mike	568
Radio Hook-ups	569
Question Box	570
Radio Patents Review	571, 572
Amateur Radio	575



Published by Radcraft Publications, Inc. Publication office: 29 Worthington Street, Springfield, Mass. Editorial and Advertising Offices: 25 West Broadway, New York City. Chicago Advertising Office: RADIO-CRAFT, 520 North Michigan Avenue, Chicago, Ill.

RADIO-CRAFT is published monthly, on the first of the month preceding that of date; subscription price is \$2.50 per year in U. S. (In foreign countries, 75c additional per year to cover postage; Canada, 50c additional.) Entered at the post office at Springfield as second-class matter under the act of March 3, 1879. All communications about subscriptions should be addressed to: 29 Worthington Street, Springfield, Mass., or Director of Circulation, 25 West Broadway, New York, N. Y.



Foreign Agents:

London—Gorringe's American News Agency, 9A Green St., Leicester Square, W. C. 2, England.
Paris—Messageries Dawson, 4 Rue Faubourg, Poissonniere, France.
Melbourne—McGill's Agency, 179 Elizabeth St., Australia.
Dunedin—James Johnston, Ltd., New Zealand.



Text and illustrations of this magazine are copyright and must not be reproduced without permission of the copyright owners.



Copyright 1942 Radcraft Publications, Inc.



“THERE IS A BRIGHT SIDE”

An Open Letter to Users of Electrical Measuring Instruments

Much more than instruments is needed to fill the vast requirements of America's gigantic production program. Experience gained by many years of actual instrument manufacturing is vital. Triplet's broad experience in filling peace-time needs is answering the call to arms—is doing its part in re-establishing in the world the Democratic ideals of freedom.

Private business must undergo restrictions for the sake of National security. As good Americans we will bear these willingly.

And there is a bright side. Rapid expansion, new fields and improved processes mark today's instrument program. New developments unbelievably revolutionary in their scope are growing out of the vast proving ground of war-time production. When war ends, these advantages will be passed on to all of you. From the experience of today will come many new and greatly improved instruments to better serve the peaceful world of tomorrow.

N. A. Triplett

Sales Manager

THE TRIPLETT ELECTRICAL INSTRUMENT CO.

FOR DEFENSE



**BUY
UNITED
STATES
SAVINGS
BONDS
AND STAMPS**

We Can All Help . . .

Buy Defense Stamps and Bonds. Buying them regularly is the best way you can help General MacArthur and our fighting men. We must all pull together now, and your dollars can best serve in stamps and bonds.

**THE TRIPLETT ELECTRICAL INSTRUMENT CO.
BLUFFTON, OHIO**

More Help from

SYLVANIA SERVICEMAN SERVICE

by
FRANK FAX



A SHORT time ago Uncle Sam told the radio-buying public, "That's all there is, there isn't any more." That puts it up to you servicemen to keep the nation's radio sets—57 million of them—in trim for the duration.

Yes sir, there's plenty of work ahead, but to get your share, you've still got to scratch for it. And that's why we've prepared a couple of new sales helps to add to the long list now available to you.

One is a set of "Radio Alert" post-cards. These emphasize the importance of good radio reception in air raids and black-outs, pointing out that radio may be the only open means of communication during alerts. The price of the cards to you is just a penny apiece for postage.

The other new item is a booklet of radio caretaking hints for housewives—a timely reminder to the ladies that their annual spring scouring should include a look-in at the radio, too.

Every one of the thirty helps listed below—including the two new ones—is obtainable at your local jobber. Or, if you prefer, write direct to me, Frank Fax, Dept. C-5, Hygrade Sylvania Corporation, Emporium, Pa.

- | | |
|--|--|
| 1. Window displays, dummy tube cartons, timely window streamers, etc. (From your Sylvania jobber only) | 16. Technical manual |
| 2. Counter displays | 17. Tube base charts |
| 3. Electric clock signs | 18. Price cards |
| 4. Electric window signs | 19. Sylvania News |
| 5. Outdoor metal signs | 20. Characteristics sheets |
| 6. Window cards | 21. Interchangeable tube charts |
| 7. Personalized postal cards | 22. Tube complement books |
| 8. Imprinted match books | 23. Floor model cabinet |
| 9. Imprinted tube stickers | 24. Large and small service carrying kits |
| 10. Business cards | 25. Customer card index files |
| 11. Doorknob hangers | 26. Service garments |
| 12. Newspaper mats | 27. 3-in-1 business forms |
| 13. Store stationery | 28. Job record cards (with customer receipt) |
| 14. Billheads | 29. "Radio Alert" Post-cards |
| 15. Service hints booklets | 30. Radio Caretaking Hints to the Housewife |

SYLVANIA
RADIO TUBE DIVISION
HYGRADE SYLVANIA CORPORATION

REPAIRING CONDENSERS

Dear Editor:

I have a low-loss ceramic-insulated mid-geet condenser which fell off my work bench and the insulating material was broken. Being the only one of its kind that I had I needed it very badly. I took a piece of good masonite and cut it just a little larger than the condenser when open and drilled the shaft hole in the middle. A smaller hole was drilled at the bottom also and then I bushed it up until the rotor plates moved freely.

This little condenser can now be mounted by drilling small holes at the top and the bottom of the masonite strip.

HOMER L. DAVIDSON,
Fort Dodge, Ia.

RE: RADIO BEAMS

Dear Editor:

In reference to your article on "Radio in Aviation" and Radio beams in your Jan.-Feb. *Radio-Craft*. This was very interesting and I, for one, would like to see lots more such articles. This article should prove of interest to flyers as well as Radiomen. Keep up the good work!

LESTER L. WILLIAMS,
Las Vegas, New Mexico.

HEAD-PHONE RECEPTION FOR HOSPITALS

Dear Editor:

Since Mr. Shaney answered my letter to him about how to get good phone reception, in your July, 1941, issue, I have been working with output transformers, different pairs of phones, condensers, tone controls, etc., and I am beginning to get pretty good phone reception. So I am becoming interested in the thing which, next to good phone reception will, I believe, help me more than anything else to get the doctors and supervisors here to make a rule requiring the use of phones with all private radios; in fact many hospitals require the use of phones with all private radios.

I wrote Mr. C. Seymour who mentioned in his letter published in your July, 1941, issue, that he maintained radios in a hospital where loudspeakers were not permitted, but I want to come in contact with more servicemen who also maintain radios in hospitals where phones are required with all the private radios used by patients.

Will you please publish this letter, excerpts from it or a small notice asking any serviceman who knows of hospitals or sanitariums which require the use of phones with all private radios to write me about them, giving their names and addresses?

JEROME FOWLER,
Tuscaloosa, Ala.

WAR-TIME USES FOR FM

Dear Editor:

In the January-February issue of *Radio-Craft* Mr. Hugo Gernsback, in his editorial "U. S. Radio At War" mentions the necessity for reliable, short range communication between planes and subs. Also "Only new radio ideas of course can be used."

I believe that there are possibilities in "FM" which may have been overlooked in this particular case. In saying this I am not criticising. Humans can be compared to the monkey who had his hand caught in the jar of nuts. They often overlook a solution that is close by, while racking their brains for an idea which will fill the bill.

FM has already joined the U. S. Army for use in tanks and scouting units, where interference makes the use of AM difficult or impossible. (No. I didn't learn this from the Fifth Columnists.) Just to refresh your

memory, some of the advantages of FM which make it a good solution to the "plane-sub" problem are:

- (1) Short-range transmission
- (2) Easy adjustment of range
- (3) Compactness of units
- (4) Low-power operation
- (5) Low-cost operation
- (6) Reduced interference
- (7) Complete absence of distortion due to station interference, and ability to "blank-out" an enemy unit by slightly increasing power.
- (8) Simplicity of equipment as compared to the ultra-shortwave transmission as suggested by Mr. Gernsback.

Frequency Modulation lends itself almost perfectly to such wartime needs, and the United States has the jump on the Axis in being able to put it to work immediately!

We are shoulder to shoulder in the fight for freedom. Let's all swing together to put the axe to the Axis and the boots to the Japs!

H. L. HEWITT,
Grenfell, Sask., Can.

SUCCESSFUL WITHOUT THEORY

Dear Editor:

I have noted what some readers have been writing, that all Servicemen are "gyps," and should be forced to get a Government license. That is what I call the "bunk." I believe that 80 or 90 per cent of the radio mechanics who really fix radios do not know theory. I have worked on the same bench with a man who knew radio theory and yet could not repair a radio as rapidly as I. *Practical experience* is what counts—and that certainly is the best school. I acquired my knowledge of radio from practical experience and yet am making a good living without theory.

As to what we would call a "quack," I believe he should keep on; he makes business good for a good mechanic. This is due to the fact that when people get to know him, they will not go back to him, but will go to a reliable mechanic.

So, men, why not let's all pitch together and not try to "knock" the so-called mechanic. There is enough work and business for us all. Let us hear from some more of your RSMA members. I would like to have one of those buttons myself.

CONRAD ALBRIGHT, JR.,
Texarkana, Arkansas.

NEW BUSINESS! SERVICING "DIATHERMY" MACHINES

Dear Editor:

We operate a Radio-Electric shop here in this city of 5,000 population. I am the radio Serviceman and have a first-class lineup of equipment and a very good record for service. I am not saying this to "brag," but only to state my position.

I recently had the opportunity to service a diathermy machine for one of the local doctors. I sent the tubes in to Chicago for test and found that one was bad, so the remedy was easy. However, after talking to several of the doctors and the superintendent of the local hospital, I have come to the conclusion that I have been passing up some good business in this line. There are many of these diathermy machines and X-Ray apparatus both here and in the surrounding smaller towns. Whenever they need service, they have to ship them in to Chicago. Naturally this takes quite a bit of time, so they are all willing and anxious to have them repaired locally.

Will someone advise me how to break into this business, where to get the neces-

sary technical service bulletins, diagrams and instructions? Can you also tell me what type of testing equipment is necessary, etc.? Can you give me something on the price schedules for labor on this type of equipment? I presume this type of work would command a much better price than ordinary radio work.

I believe there are lots of us who are passing up service work like this, either because we have never thought of it or have hesitated to go into it. After all it is in our line and should be "right down our alley." It should be worked up into a profitable source of income.

I am a regular reader of *Radio-Craft* but do not remember seeing any article on this type of service.

Any help you can give will be greatly appreciated.

By the way—after replacing the tube in the aforementioned diathermy it worked perfectly. The doctor wrote to the company and told them I had "repaired" it very efficiently, and asked for service notes and a diagram. They answered by saying that they did not divulge any information concerning their machines and did not publish diagrams. But, would he contact his serviceman, ask him to write to them and tell them what the trouble was and how he corrected it, so that they in the factory might try to remedy that in future machines before they left the factory! Now, isn't that nice! They will not even offer to help, but expect the poor Serviceman to give them all the hard-earned information he has gained!

R. H. JURGENS,
Madison, S. Dak.

HELP THE "HOME EXPERIMENTER"

Dear Editor:

I think the beginner in radio is due a good deal of attention and encouragement from others who have preceded him in this field. A good many of these beginners are handicapped by lack of money in their endeavors to get ahead and, as a result, some become discouraged and turn towards something else that, although less money is involved may not be as profitable in the end.

Many of these beginners become wholeheartedly interested in radio, and, as a result, do a good deal of experimenting, if they can obtain the equipment with which to work. Quite often one reads of some person interested in certain type of work, experimenting with simple equipment in his "home workshop," and suddenly making a discovery that astounded learned scientists, with their great modern laboratories filled with the best and most expensive equipment. If that person had given us his experimenting and turned in another direction, because of difficulties in obtaining his simple equipment, and because no one encouraged him in his endeavors, the world would have gone on for scores of years, perhaps, ignorant of what might be the greatest discovery of all time.

I don't mean to say that all "home workshops" would turn out famous inventors, but I do say that there would very likely be a greater percentage, if these beginners were given encouragement from such sources as the local servicemen, the amateurs and the schools. The schools could provide simple, inexpensive equipment and, although not including it in the curriculum, they could encourage students to carry out experiments and do simple set-building, in order to master the first principles of radio. In this manner the beginner would have access to equipment that would, perhaps, be too expensive for him to own.

Many servicemen, amateurs and other people have old discarded sets using the old type tubes, such as the 27's, 35's, etc. If they would turn these over to the experimenting beginner in radio, they would do much to encourage him at this stage of his education.

These old tubes and other parts are not as nice to work with, I grant you, as the newer ones; but *they will work*—and in using them he can carry out quite a number of excellent experiments. For one thing the parts cost him next to nothing, for most people are glad to get rid of them; also, if he burns out a tube or breaks a part, he does not suffer much expense in replacing it.

As time goes on he can save more money and purchase better equipment with which to work. Eventually he will want to take a course in radio engineering and become a full-fledged radio technician. However, without that little bit of attention and encouragement from others, he would, perhaps, still be an insignificant figure among the millions, working away at a low-paying job he may not like. It is needless to repeat that in these days of war there can't be too many well-trained radio technicians.

So, how about it, you people that are able to help these would-be radio hams? Are you going to hand out that old discarded radio and electric equipment from your attics or cellars, and hand it over with your best wishes? You have nothing to lose and everything to gain, so get busy right away, won't you?

GERALD CHASE,
Burford, Ont., Can.

THE RADIO REPAIR MAN

Dear Editor:

Every day throughout the country, hundreds of radios are repaired. Back of all this repairing you will find the "repair man." Although few people realize it, this man controls, to a certain extent, whether or not the public hears the news, their favorite music or actor, and public leaders. Probably the servicemen did not think of this angle of their work themselves.

Actually the radio repair man is performing a public service. He represents one of the pillars of democracy. His never-ceasing work may be compared to a doctor's practice. No matter what hour the need arises, the radio repair man is ready to go anywhere to repair anyone's radio. Of course as with doctors, so with repair men, you will find men who are not upholding the honor of the radio trade, but merely *working for themselves*. This kind of man you will find in every profession, but fortunately, they are few and far between.

Too many people take the repair man as a "standardized" member of the community, little realizing what they would do without him. He is one man in your town you can depend on to be ready at all times for whatever might come along. In the summer you will find him stocked up with batteries for your portable radio. Yes, and most likely he will be ready to rent you a portable radio for your fishing trip, or a small mantel set for summer cottage use. Then again he will have plenty of flashlight batteries, because the summer time is the time when more flashlights are used.

But no matter what time of year you take your radio to him, you will find him ready to give you the prompt and courteous service he advertises. Yes, you can truthfully say that the radio repair man is a credit to and a builder of our country.

D. McBRIDE,
Newmarket, Ontario, Can.

TECHNICAL BULLETINS

Technical bulletins give reliable information in easy-to-follow form, and save valuable time otherwise spent in laborious reading of numerous books. Every subject is treated briefly and concisely, yet completely. No complicated mathematics, chemistry, electricity, or theory. Each bulletin is written in simple language.

PRICE \$1.00 EACH POSTPAID
ORDER BY NUMBER

D-101—USING NICHROME RESISTANCE WIRE.—How to repair electric flat irons, toasters, rheostats, resistors and other electric heating devices. Figuring lengths and sizes of wire for any job.

D-113—HOW TO DESIGN SOLENOIDS AND PLUNGER MAGNETS.—Anyone who is interested in solenoids or plunger magnets cannot afford to be without this non-mathematical, simple and practical information.

D-129—COLORING METALS CHEMICALLY.—Formulas for producing colored finishes on brass, copper, iron, aluminum and alloys by simple chemical processes.

D-132—WORKING WITH PLASTICS.—Information about new material that combines advantages of wood and metal.

D-141—RECORDING THERMOMETER EASILY MADE.—Information on building device to record temperature changes over 12 hour periods. Uses any type of clock and a sensitive element carrying a pen that marks temperature fluctuations on a paper chart.

D-104—SILVER SOLDERING AND BRAZING.—Practical methods of brazing, silver soldering, and hard soldering. Tables giving the composition of brazing and soldering alloys, and fluxes.

D-119—ELECTROPLATING WITH ALLOYS.—New practical processes for bronze, brass and cadmium silver alloys.

D-121—CORROSION, CAUSES AND PREVENTION.—Information about corrosion and methods of controlling its destructive effects on plumbing and heating systems, tools and machinery, automobiles.

D-139—RUBBER MOLDS FOR CASTINGS.—Instructions for making the original model, preparing the rubber mold, and casting useful articles from liquid plastic, magnesite and other materials.

D-108—ELECTROPLATING WITH GOLD AND SILVER.—Formulas and instructions for electroplating with gold and silver by efficient Process. Formulas for green gold, red gold and other finishes.

D-122—STAINLESS STEEL EASILY SOLDERED, BRAZED OR WELDED.—Complete practical methods of soldering, brazing and welding stainless steel. Including formulas for solders and fluxes.

D-126—HOW TO DESIGN AND BUILD HYDRAULIC RAMS.—Complete directions for surveying springs and streams. How to build and install hydraulic rams.

D-146—SIMPLIFIED CASTING METHODS.—Simple and rapid methods of making castings in soft metals without sand molds, for models, ornaments, toys, and many useful articles.

Each Bulletin consists of a set of large sheets, assembled in one packet, size 9 x 14½"; weight ¼ lb. Numerous illustrations, diagrams, charts to supplement text.

TECHNIFAX

1917 S. STATE ST. (DEPT. 542) CHICAGO, ILL.

DEPT. 542

TECHNIFAX 1917 So. State, Chicago, Ill.

Enclosed find \$..... for which please send me postpaid the following Technical Bulletins:

Nos.

Name

Street and Number

City and State

EXTRA QUALITY COUNTS MORE THAN EVER THESE DAYS...



INSULATED METALLIZED—The only resistors with the famous Metallized-type element (except IRC "F" type and high-power and high-voltage types produced for industrial use). Completely sealed and insulated from end to end. Moisture-proof and vibration-proof. 1/2-, 1- and 2-watt sizes.



POWER WIRE WOUNDS—They dissipate heat faster—stand overloads better—are protected against moisture by an exclusive Climate-Proofed Cement Coating. 53 standard sizes and shapes, also many special types, from 3- to 200-watts, fixed or adjustable, inductive or non-inductive.



CONTROLS—POTENTIOMETERS—Quiet—and built to stay quiet. The only Controls with the noise-eliminating features of Metallized-type element bonded to a moisture-proof base; S-finger "knee-action" contactor; and spiral connector which eliminates metal-to-metal wiping contact.

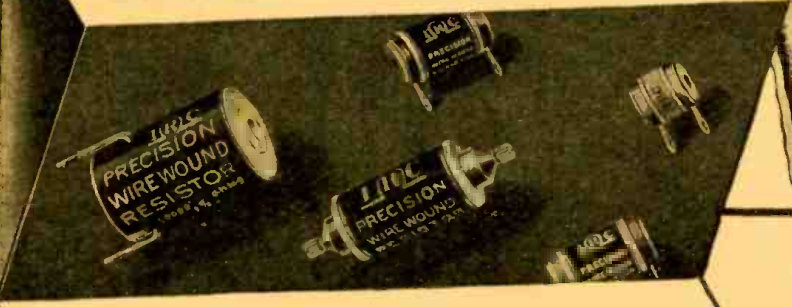

PRECISION WIRE WOUNDS—Designed to combine a high degree of accuracy with real dependability and modest cost. Made in 14 types. Inductive or non-inductive windings. Standard accuracy is 1%, or to as low as 1/10 of 1% on special order. Impregnated against atmospheric conditions.

IRC Resistors and Controls represent the greatest values for your money—not that they cost less, but because they are built to perform better and last longer.

Quality and dependability are now more important than ever in keeping the nation's radios in good working order when almost every day brings War news and other broadcasts of utmost significance, no radio owner will want to miss.

BUILDING BUSINESS—FOR YOU!

This little tag, packed with all IRC Volume Controls sold through the jobbing trade, is designed to hang on the control knob whenever you make a replacement. No customer will fail to see it. None will fail to be impressed with the fact that you have used a replacement of the highest quality. The reverse side has space for your name, address and 'phone number and suggests that satisfied customers recommend your services to friends.



INTERNATIONAL RESISTANCE CO.

401 N. BROAD ST., PHILA., PENNA.

RADIO-CRAFT

Incorporating

RADIO & TELEVISION

"RADIO'S GREATEST MAGAZINE"

*... Radio in War
is both Vital and
Useless ...*

A COMMUNICATIONS PARADOX

By the Editor — HUGO GERNSBACK

THE present war has been termed a mechanized war and a war of communications. One without the other is unthinkable. Coordination of land, sea and air forces is a tremendously vital matter and—as has been shown repeatedly in this war—battles begin to be lost when there is no rapid coordination between the various forces. But, you cannot have rapid coordination without radio nowadays.

Yet paradoxically enough, the all-important radio communication frequently becomes quite useless and we are plunged once more back into the days of the sailing ship, particularly where war-time naval communications with land is concerned. Both in the Atlantic and in the Pacific, it has been demonstrated repeatedly that neither surface vessels nor submarines (nor airplanes for that matter) can safely use radio transmitters during war except under especially favorable conditions. Submarines are wary of using radio lest they betray their position, which usually means quick sinking of the submersible. Nor does a naval armada use radio except in home waters, and often not even then. A naval fleet in enemy waters would commit suicide if it were to transmit radio messages indiscriminately.

Particularly in the Pacific both American and Japanese naval forces cannot use radio transmission at all when it comes to communicate with the home bases. When Japan sent her fleet on their nefarious task which ended on December 7th with Pearl Harbor, they did not betray their whereabouts by radio signaling.

And, when late in April American bombers struck at Japan proper, bombing Tokio, Yokohama and Kobe, paradoxically enough the news to the world did not come from American sources, but from Japanese broadcasts! As we go to press, five days have elapsed and still the United States Navy Department is silent. Of course there are excellent reasons for this. The American Task Force which performed the remarkable feat of bombing Japan proper, cannot be so foolish as to reveal its position by using radio. It should be remembered that the enemy *listens!* He listens always—and he has most excellent ears. Not only does he listen but if the American Task Force had given away their location by radio, the Japanese listening posts would have known the exact spot from which the broadcast originated by what is known as *triangulation*. By having two Japanese stations several hundreds of miles apart draw a bead on American naval vessels on the high seas, its exact location is divulged within a matter of minutes. Then it would be a simple matter for the Japanese War Department to notify its naval units in order to intercept the American Squadrons—and that is precisely the reason why an attacking force not in its own home waters cannot use its radio transmitters safely. While our Navy has ears too, and excellent ones, with which to listen it cannot talk back except under unusual circumstances.

Remember also that we have a terrific disadvantage when we attack Japan, on account of the vast distances which our Navy must traverse in order to get at the enemy. Therefore it will take days and perhaps weeks for the Navy Department to finally

announce a victory or a battle that took place long ago, with the results which may already have been broadcast by the enemy.

Thus during war time, even with the modern instrumentality of radio, we are back to the sailing vessel days, as far as quick communication with the home land is concerned.

That is a regrettable matter but in war safety comes first and I firmly believe that the odd situation in which we find ourselves today will not prevail in the future.

I am certain that before very long American naval units will find a way to overcome this great silence handicap. I suggest one method how the problem may be solved with perfect safety to the Navy.

I refer to the *Radio Sonde*, which has been used and is still being used a great deal to make meteorological observations. These radio Sondes are small balloons, only a few feet in diameter which take aloft an extremely light-weight radio transmitter. Nowadays they are sent up into the stratosphere where the balloon bursts. The radio Sonde then descends by a small silk parachute. Going up as well as coming down a small radio transmitter sends a series of signals to earth which give the listening scientists certain information as to air conditions up in the stratosphere.

Suppose in the future the Navy, after completing its task, wishes to transmit a complete communique to a distant or home base. The message is prepared on a perforated paper tape with the code punched in holes. This tape is wound on a light spring motor and the radio Sonde is then liberated from the Naval Task Force, whenever the naval vessels have reached the point which they know will be suitable for the purpose. Remember that the radio Sonde now is an *independent transmitter* that floats in the air and is carried along by the steady winds of the upper stratosphere. The balloon is adjusted in such a manner that it can stay aloft as long as necessary before bursting. A small clock-work which can be set for any pre-determined time will begin to operate the short wave radio transmitter within 12 or 24 hours or whatever lapse of time unit is considered safe. A few non-radio balloons will have been sent aloft first to find out the direction of the wind. Then when the radio Sonde is ready to transmit its message to the world it may be a thousand miles or more distant from the ship that released it. It therefore can not reveal a vital position nor can it possibly give aid to the enemy.

More important than the actual official message from our own fighting forces at sea, it will give us concrete facts rather than vague talk. Broadcasts by the enemy to those interested always understate or minimize facts rather than to tell the full truth.

The radio Sonde cost only a trifling amount of money and can be sent aloft at a cost of less than \$100. It is destroyed when it sinks into the sea, or for that matter some means can be used to destroy it by explosives, if this should be deemed necessary, upon landing either on land or sea. There appears to be no valid reason why such radio Sondes should not be used soon.

• THE RADIO MONTH IN REVIEW •

The "radio news" paper for busy radio men. An illustrated digest of the important happenings of the month in every branch of the radio field.

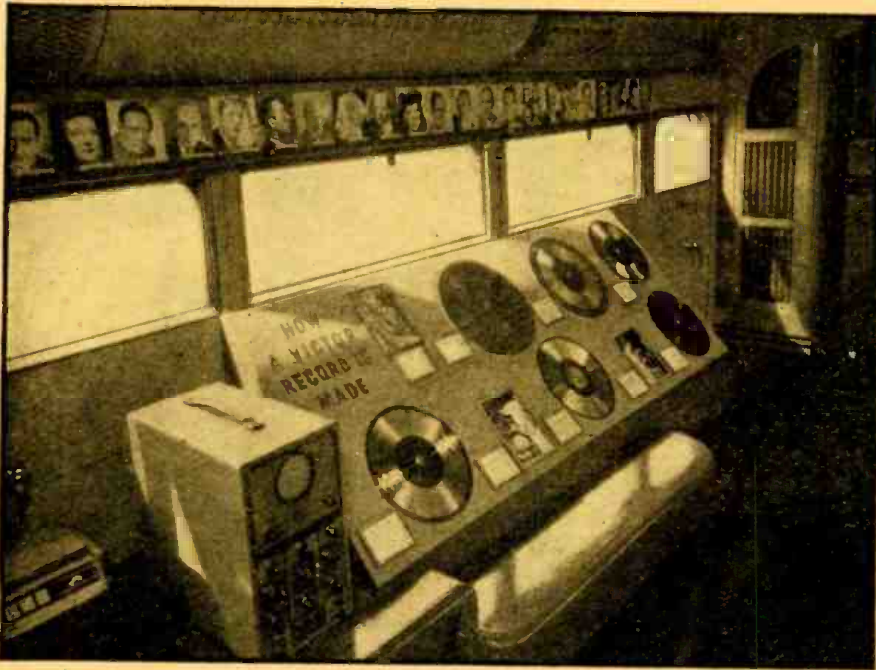

Interior of the sound coach provided by RCA Victor for the nation-wide tour of Lucy Monroe, to promote the sale of defense bonds and stamps, exhibits several phases of sound as applied to defense industries. Records are emphasized because of their value in morale building, when played over industrial sound systems to offset peak fatigue periods during the working day. The coach, with self-contained power plant, is equipped to project sound in every direction with tremendous power.

RCA AND TREASURY DEPT. SPONSOR LUCY MONROE TOUR

Lucy Monroe, noted soprano and first of the radio and concert artists to give up commercial activities to devote full time to war service, is conducting a country-wide tour sponsored by the Treasury Department and RCA Victor to promote the sale of defense savings bonds and stamps.

A specially equipped and colorfully painted sound coach, supplied by RCA Victor, is accompanying Miss Monroe. Used to publicize the meetings throughout each community, the coach contains an exhibition of sound amplification equipment aiding the war program. Powerful loudspeakers are concealed in the vehicle to direct sound over a wide area. The coach is in charge of James McCarville.

AMPLIFIER LOCATES TRAPPED PERSONS

A new use for amplifiers and microphones has been found in Europe and other countries, where bombing raids have been carried out. A microphone is placed at one end of a large horn. The horn is moved over the ground where it is suspected people have been trapped by falling buildings. The amplifier greatly magnifies any weak voices picked up by the microphone. The listener uses a pair of sensitive headphones so as to hear the slightest sound picked up by the mike.

The apparatus works "two-way" and once the voices have been heard (or even before they have been heard) the voice of the engineer in charge of the searching party can be projected through the ground for quite a distance, by means of the large horn, which is also fitted with a loudspeaker unit.

DE FOREST TURNS LIGHTS OFF BY RADIO

Dr. Lee De Forest, inventor of the audion tube which made radio possible, demonstrated recently before members of the New Brunswick-Highland Park Defense Council his newest invention, which he calls the "blackouter."

The radio device, weighing less than five pounds, is designed to extinguish electric lights automatically in the home or on display signs. It is connected to the light current and a radio aerial, then tuned to one of the major networks on a twenty-four-hour basis. When an air raid signal is sounded over the radio station the lights automatically are extinguished.

After the alert has been sounded, the lights may be turned on manually or by means of a time-delay switch which could be hooked to the unit. This switch would turn the lights on shortly after the station resumed broadcasting.

One unit could be used to control lights in a whole block of stores, the inventor asserted. It would be more practical, however, he remarked, for one storekeeper or a small group to install the units because the cost of wiring a large number of stores in the necessary sequence would be large.

FIFTY-SIX MILLION RADIO SETS IN USE

There were 56,000,000 radio sets in use in the United States in 1941, of which 30,600,000, or 86 per cent, were in homes, according to figures made public by the National Association of Broadcasters.

The Research Division of the National Broadcasting Company, through H. M. Beville, Jr., Division head, and Barry Rumble, Chief Statistician, cooperated with the NAB in making the survey. There have

been no Government census figures on radio sets in several years, and the last one made, and as yet not released to the public, is only up to 1940.

The NAB figures show that there were 16,400,000 sets in use in institutions, places of business and additional sets in homes, and 9,000,000 sets in automobiles.

The increase last year over 1940 showed 1,300,000 more sets in homes, 1,000,000 automobile sets in use, and 3,600,000 more radio sets in institutions, places of business and additional home sets.

Avoid dictionaries department:—Here's the best definition of FM and AM we've run across; from an F.C.C. report:

"Modulation is a process of imparting sound or other signal (intelligence) to a transmitted radio wave. The radio wave has two defining characteristics—amplitude and frequency. With amplitude modulation the sound controls the amplitude of the radio wave transmitted, while the frequency remains constant. In contrast, frequency modulation varies the frequency of the radio wave while the amplitude remains constant."

AIR WARDENS ATTEND TELEVISION CLASSES

Winning the war being the most serious business at hand, television has now enlisted for the duration. Its first assignment is the training of some 54,000 air wardens in the New York, Philadelphia, and Schenectady-Albany metropolitan areas, which air wardens in turn will be better prepared to train hundreds of thousands of others.

"Because our organization believes firmly, and has always felt from the beginning of our television pioneering, that video broadcasting has tremendous educational possibilities, we are happy indeed to join NBC, RCA, GE and Philco in the present television training course for air wardens," states Allen B. Du Mont. "We have installed Du Mont television receivers, in collaboration with the other organizations, so as to equip the 84 precinct classrooms in the five boroughs of Greater New York.

"From our own observations we have every reason to believe that television instruction is not only highly practical in saving much manpower and equipment, but is the only feasible means whereby this excellent defense course, under the supervision of Commissioner Lewis J. Valentine and Deputy Commissioner John H. Morris, Coordinator of Police Department Civilian Defense, could possibly be made available to tens of thousands of air wardens scattered not only throughout the vast New York area, but likewise in Philadelphia, Schenectady-Albany, and doubtless other areas which will be brought into this television-instruction network shortly. Such training is uniform and simultaneous. It is fortunate that the television signals of the NBC station in New York can be picked up and rebroadcast at distant points with such satisfactory results.

"The television sessions at 10:30 and 11:30 A.M.; 3:00, 4:00, 8:00 and 9:00 P.M., on Monday, Tuesday and Wednesday each week, for six weeks beginning February 23rd, make it practical for air wardens to attend regardless of their bread-and-butter occupations. Certainly NBC deserves unstinted praise and thanks for the hard work and cost involved in putting on six sessions each day for eighteen sessions per week, with the necessary actors, scenery, actual bombs and other paraphernalia, diagrams and so on. Likewise the New York Police Department for assigning Lieutenants and Captains to head the lectures."

WHEN TWO MIKES BEAT ONE!

Frank Forest, tenor on the "Double or Nothing" show heard over KHJ-Mutual Don Lee Mondays 8:30 p.m. PWT, is indebted to the Mutual engineer who suggested that he use two microphones to accommodate his voice range. One is placed in the usual place in front of the singer with the other one about 10 feet away. When Forest goes into a high note, microphone number one is closed and the other microphone is depended on to pick up his voice.

NEW DEVICES TEST AIRLINE SETS

Two new devices for testing aircraft radio equipment have been designed and produced by United Air Lines for use in service shops along its routes.

One of the devices, designed by H. N. Wilcox of the laboratory staff, is a *vibration generator* for testing radio equipment under conditions considerably in excess of those encountered in flight. An air-operated generating unit with an electrical frequency control is connected with a test table which can be rotated through 360 degrees for inspection of equipment during test. A means is provided for increasing or decreasing the amplitude of vibration, with a maximum intensity of 3 g's for a 100-pound load. The frequency of vibration is constant at 30 cycles per second.

The other device, designed by E. A. Jensen, also of the laboratory staff, is a signal generator for aligning and measuring the frequencies of all radio receivers carried aboard United's Mainliners. The equipment is made for the operation of 24 crystal-controlled frequencies but can be adapted to as many as 40. It has an output ranging from one millionth of a volt to one volt and is capable of modulation up to 100 per cent at six different audio frequencies.



NEW "SHAKE TEST" FOR RADIO: Here is United Air Lines' newly-designed vibration generator for testing aircraft radio equipment under conditions considerably in excess of those encountered in flight.

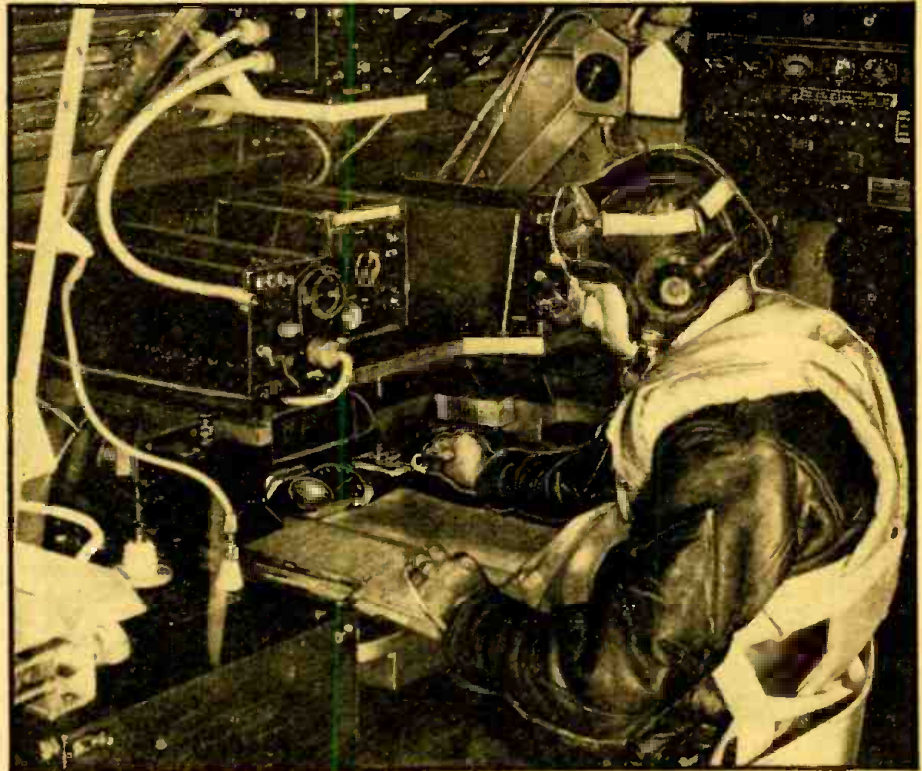

NAVY BOMBER RADIOMAN AT WORK: The accompanying official U. S. Navy photo shows the radio operator on the job, aboard one of our Navy bombers. Radio today is tremendously important in all operations, especially where bombers are engaged on long flights. Radio keeps the plane in contact with the "home base" and conversations are also carried on between the various planes in the bombing squadron. In some cases the bombing plane checks on its objective by taking directional bearings on broadcast or other stations operating in the enemy territory.

LAST RADIO-PHONOGRAPH COMES OFF RCA LINE

The last radio-phonograph for civilian use rolled off RCA Victor's Camden assembly line on Tuesday, April 7. It was also revealed that the final commercial radio chassis to be built at the Company's Camden factory for the duration was completed 50 days ahead of the deadline set by the War Production Board.

The WPB on March 7 ordered the manufacture of radios and phonographs for home use to be discontinued after April 22. A provision in this order permits the companies to complete the instruments on which they had begun assembly on or before April 22, under the limited production quota provided for in a previous order. However, with the completion of the last chassis on March 5 and its installation on April 7, all phonograph and cabinet assembly operations at the Camden plant ceased that day.

According to Robert Shannon, president of the RCA Manufacturing Company, the WPB order did not find his company unprepared.

"As far back as September, 1939, when the Nazi hordes began to over-run the European continent, our Company's leaders foresaw that radio and sound would be called upon to play a more important role in our country's history than ever before.

"Long-range plans were laid then for the conversion of plants, machinery, materials, and man-power to our country's requirements as they would become needed."

By pushing its commercial radio work out of the way at the Camden plant weeks ahead of the WPB deadline, Mr. Shannon declared, the company gained valuable time in its conversion process. Immediately after the last radio-phonograph instrument was taken from the final assembly line, demolition squads went into action in the first step toward converting the remaining facilities of the radio plant at Camden to total production of radio and sound equipment for the armed forces.

TIGHT SEAL BETWEEN IRON AND GLASS

Tight seals between iron and glass, eliminating the need for nickel and cobalt, critical war metals, for wires leading into certain types of vacuum tubes, are now being made with a new development of General Electric scientists. Dr. Albert W. Hull and Dr. Louis Navias, of the G-E Research Laboratory, have just been granted a patent for their invention.

From early days of the electric lamp, a problem of construction has been to make a tight seal between metal and glass. It is also involved in making radio tubes. Even with tubes in which the glass shell is replaced by one of metal, the lead-in wires pass through glass insulating bushings.

Since nickel and cobalt (previously used for the purpose) are used in many ways for war equipment, and their supply is extremely limited, the new invention of Dr. Hull and Dr. Navias is an important one, since for certain applications, it permits tight seals to glass without their use. They have devised a series of glass compositions which can be used with iron and certain iron alloys. One consists of 45 per cent silicon dioxide, 14 per cent potassium oxide, six per cent sodium oxide, 30 per cent lead oxide and five per cent calcium fluoride. The rate of expansion of these glasses is very close to that of iron.

In seals using these glasses a further and separately patented invention of Dr. Navias also proves useful. When a glass containing lead is sealed in contact with iron, some of the lead atoms migrate from the glass into the metal. This weakens the joint, and may let air leak into the tube. Dr. Navias proposed placing a thin layer of lead-free glass directly over the metal, then sealing the lead-containing glass to that. The thin glass layer prevents the lead from reaching the iron, yet it is not thick enough to crack and let air in.

HAND RADIOPHONE

Front Cover Feature

H. W. SECOR

The most compact short-wave transmitter and receiver yet constructed is the one here portrayed. It should find wide-spread use in Defense Plants.



The pressure of a finger on a control switch permits the operator to "talk" or "receive."

OUR front cover picture illustrates a completely self-contained, radio-telephone combination transmitter and receiver weighing only four pounds, and not much larger than the handset of a "French" telephone. The unit is being made available to governmental agencies and services, including municipal divisions, public utilities, fire and police departments, railroads and other transportation agencies, etc., subject of course to licensing by the Federal Communications Commission, as well as priority rating.

Believed to be the most compact and lightweight complete transmitting and receiving outfit ever produced, the built-in battery power supply for the new Weltronic "transceiver," under continuous operation, has a rating of about 8 hours. This is equivalent to approximately a week to a month's operation under normal intermittent service. The power supply is derived from standard commercial batteries in order to keep battery replacement cost at a minimum and facilitate maintenance of operation.

With a range of upwards of a mile over land, the units are provided with "off" and "on" switches and finger-operated selector to change from transmitting to receiving and vice versa, while talking through the unit.

As the front cover picture shows this transceiver is ideal for use by guards around defense plants. The advantage of its use for this purpose is that guards can be spotted at various points, or can move around and can report at any time to the central receiving unit, which may be fitted with a loud-speaker amplifier. It has definite advantages over normal simple alarms such as whistles, since it permits conversations and arrangements for handling suspicious persons without warning them in advance.

Although these transceivers are designed for operation on a single wavelength, thus requiring no tuning in service, their frequency range is adjustable from 112 to 300 megacycles ($2\frac{1}{2}$ to 1 meter) through a simple externally accessible screw adjustment.

Also provided on the units are a volume control and a detachable adjustable short fish-pole type of aerial.

Construction of the set is as rugged as that of a commercial telephone unit.

In operation, when the toggle switch is thrown into the "on" position, the unit is

"receiving." To talk through the unit, it is necessary merely to pull the selector finger lever down against light spring pressure. Releasing the selector lever switches the unit back to receiving again.

The transceivers may thus be used in pairs or groups with or without a central receiving and transmitting control station.

TECHNICAL FEATURES

The Hand Radiophone shown on this month's cover is a very ingenious short-

wave radio telephone transmitter and receiver, or what is commonly known as a transceiver. This apparatus is covered in the U. S. Patent No. 2,276,933 issued to Cletus J. Collom of Detroit, Michigan. This transceiver employs a circuit fairly familiar to radio experts. When the switches shown are turned to one position, the apparatus is in condition for talking by short wave to any other station or "post" one-half mile or more away. When the switches are thrown to the opposite position, the apparatus is then converted for receiving purposes. The apparatus should find many applications for the protection of war-time industrial plants. Following the suggestions made by Mr. Gernsback in a recent editorial—such 2-way sets might, if they had been used, have saved the giant *Normandie* from the disastrous fire which she suffered.

The switching of the apparatus from transmitting to receiving is carried out by means of a switch, actuated by the hand which holds the complete apparatus.

The antenna is of the telescopic type and may be extended for tuning or for increasing the range. The complete transmitting and receiving set is actuated by small dry batteries contained in the housing cabinet. A telephone receiver is mounted in the cap at the upper end of the apparatus (for listening), while a sensitive microphone is mounted in the cap at the lower end of the instrument, in proximity to the mouth of the person using the apparatus. One form of adjustable antenna may be that similar to the collapsible steel rule, which rolls up inside the case when pressure is exerted upon it.

This article prepared from data supplied through the courtesy of the Weltronic Corporation.

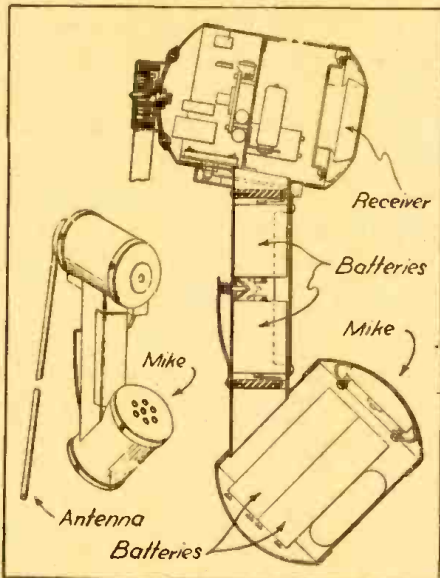

Above—Sectional view of the "Hand Radiophone" here described. Below—Wiring diagram, as shown in the patent covering the transceiver.

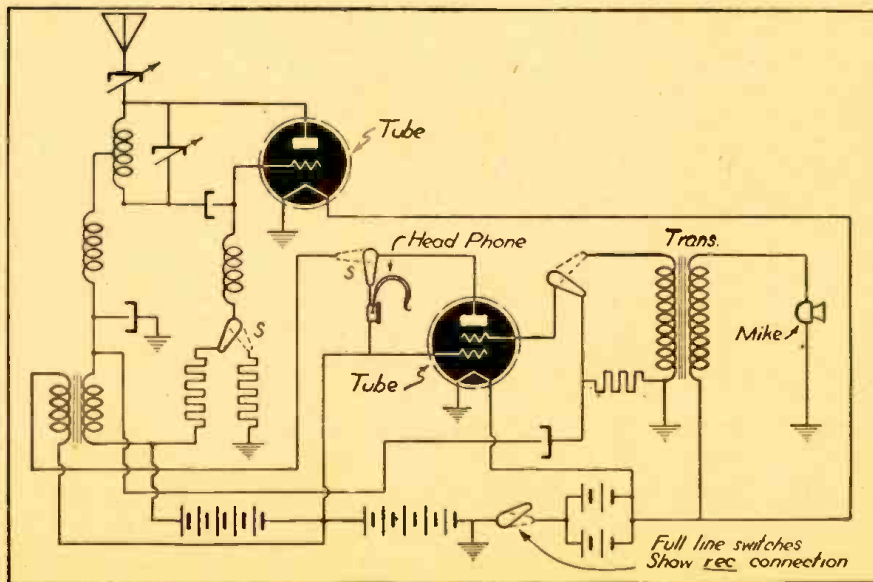



Photo by U. S. Army Signal Corps.

Left:—Col. A. Robert Ginsburgh recently led a group of Army officers on a visit to the Vultee Aircraft plant. Sgt. D. Symington is seen talking to C. A. Phillips, a Vultee employee, on the electrical installation bench. Right:—The author soldering radio switch panel.

The RADIO MAN

Keeps 'em Flying

E. H. LEFTWICH

The excellent opportunities open to the Serviceman in the aircraft industry are explained by the author. Men are needed, at good pay, for assembling radio sets for planes and installing them in the planes. Don't fail to read Mr. Leftwich's article.

THE foreman turned from the blueprints at his desk and faced me. I wondered if I had stuck my neck out again. But he laid a friendly hand on my shoulder and grinned.

"Tomorrow, Ed," he told me, "I'm making you a lead-man."

For a moment everything went haywire all around me. Things began to whirl and swim about in mad confusion. While I grabbed the back of the foreman's chair to steady myself, something choked up inside of me. A few seconds . . . and I came back to earth.

"Thanks, a lot, Jim," I managed to breathe, and the staccato pounding of the riveters in the next department almost drowned out my words. "I'll do the best job I can."

"I know you will, Ed. You'll have charge of all the soldering on our ships." Again, he grinned. "Now, fly into it and show me what you can do."

Sitting at my desk, going over my jobs for the night, I looked over my own crew . . . the crew of ex-servicemen, amateurs and electricians, whose work I was now responsible for in the tremendous bomber plant. I'd wanted this job. . . . Lord how I'd wanted it, worked for it and looked forward to it as a goal of real achievement.

It wasn't hard for me to look back, just a year ago, to the time when I'd first started in the aircraft plant. Then, I wouldn't have dreamed of a job such as this. A few yards away, on my right, stood my supervisor, the same one I'd had when I started, and he knew all the answers.

A big, jolly ex-radio serviceman, who formerly owned his own shop, Ken was okay then, just as he is now. The night I started to work, Ken had said, "I've heard about you, Ed. You're one of the old-time servicemen, and I'm glad to have you

here in Radio and Electrical Sub-assembly. Your radio knowledge will help you a lot, but you'll have to learn to do things *our* way, of course."

And did he put me through! Night after night, I sat at my bench learning to solder the way aircraft assemblies *have* to be soldered, and believe me *that* soldering has to be just about perfect. There were dozens of different assemblies, radio and electrical to wire, and these jobs were a long way from the auto-radios, midget broadcast sets, haywire transmitters and receivers I'd been wiring.

You see, aircraft equipment has to be *right*. It's a matter of life and death, and now that we are in the war, it means more than ever before.

Even to an old-time radio man, the many different jobs in our department looked complicated and confusing. I wondered if I'd ever be able to thoroughly master all of the different assemblies. You think that wiring up a super-het is a tough job? I used to think so, too. But just wait until you see an aircraft assembly for the first time!

Ken put me through the mill . . . and I liked it. Any man who likes to do a real job, one that he is proud of, would have liked it, and after a while my work began to stick and stopped coming back from Inspection department.

In the modern aircraft plant, the radio serviceman can be easily trained to fit in like the cellophane wrapper on a cigarette pack. From his former experience, he knows how to solder, to wire and install equipment. If he likes to build equipment, Sub-assembly is where he belongs. If he'd rather install wiring and equipment, there are places for him on the Final-assembly line. Then, there are Testing and Inspection departments where the radio serviceman

will surely feel perfectly at home.

Almost without exception, our Inspectors are hams and former servicemen. Our foreman is an ex-navy radio operator and speaks our own language.

Working conditions in an aircraft plant are ideal, and even though our war program calls for intensive all-hour production, officials realize the importance of the human element. These things are never neglected for a moment, and there is full co-operation between the company and the employees. Everything possible is done to promote safe, sanitary and harmonious working conditions.

Personal problems which arise from time to time are taken care of without delay and in a manner which takes into consideration the personality of the particular worker. The amazing progress of the American aircraft industry is largely due to this almost unbelievable spirit of co-operation, which I do not hesitate to say was present long before we got into the war. Aircraft officials never take the "know-it-all" attitude. Rather, their viewpoint is that, "5000 heads are better than one."

In our plant there are from ten to twenty-five cash awards made each month to employees for original devices which do a certain job better and quicker.

It is certainly advisable that a great number of servicemen stay on their jobs to "keep 'em playing," because Uncle Sam wants the public to know about things, especially in cases of emergency, but there are many jobs open in the aircraft field for the radio serviceman.

After the war, the aircraft industry will come into its own, in a big way, and thousands of responsible jobs will be made here for the radio serviceman, because . . . you can't "keep 'em flying" without radio equipment!

"WAR-TIME" SERVICING

WILLARD MOODY

How may the Serviceman safely substitute low voltage condensers for those of higher rating? How does one calculate the relative carrying capacity of substitute resistors? These and many other questions facing the War-Time Serviceman are answered in the accompanying timely article by Mr. Moody.

THE radio serviceman on the home front is going to be called on to repair sets for which exact replacement parts are no longer obtainable. To many men this will mean the exercise of an ingenuity which in former years might have been lacking and unused. The most common question which arises in the minds of radio men is the effect of using a condenser which is larger or smaller in capacity than the original.

Let's take a practical example. A certain receiver has a power supply using an 8 mf. input filter, followed by a field coil serving as a choke. The second filter condenser is also an 8 mf. unit. Now, the voltage rating of the original units is 450 volts. A serviceman has a dual condenser having a capacity of 16-8 mfs. at 450 volts. How should he connect the replacement condenser? It is assumed that the choke is in the positive leg of the circuit.

We know, from radio theory, that the peak current to the rectifier tube will be a function of the first filter condenser capacity and other factors. Therefore, we appreciate that it is not wise to install a larger unit capacity than the original for the first filter condenser than about 10 mf. (plus 20% roughly). We therefore take the 8 mf. section of our replacement and connect it from the rectifier filament to ground and the second condenser of 16 mf. from B plus to ground. The 16 mf. unit results in better filtering and gives slightly improved bass response since the lower audio frequencies are more readily shunted to ground through the lower reactance of the 16 mf. in comparison with the original 8 mf. condenser. *A safe rule to follow is that the rating of the condenser used as a replacement should equal the voltage rating of the original, but should never be less than the original.* It may, on the other hand, exceed in voltage rating the original unit. The capacity of the first filter condenser should not be increased by more than 20 per cent over the original for the first filter input condenser and for grid coupling condensers or condensers in A.V.C. circuits. Plate return or screen return by-pass condensers are not critical and may have larger capacities than the original, but the voltage rule given above must always apply.

In many cases smaller capacities than the original will be available. Suppose, for example, that we had a triple section condenser of 4-4-8 mf. (Fig. 3) and wanted to use it in the above power supply. The voltage rating of the condensers is 450 volts. By joining the two 4 mf. units together and connecting to the rectifier filament and ground we have the first filter condenser and the 8 mf. unit takes care of the B plus. The 4 mf. unit was installed along with its twin at the input for the reason that if one 4 mf. unit opens up the set will still play with the remaining one. Of course, there is also the danger that if one unit shorts the other will be worthless, but if the first condenser shorted the power supply would be inoperative if the 8 mf. unit were used—anyhow.

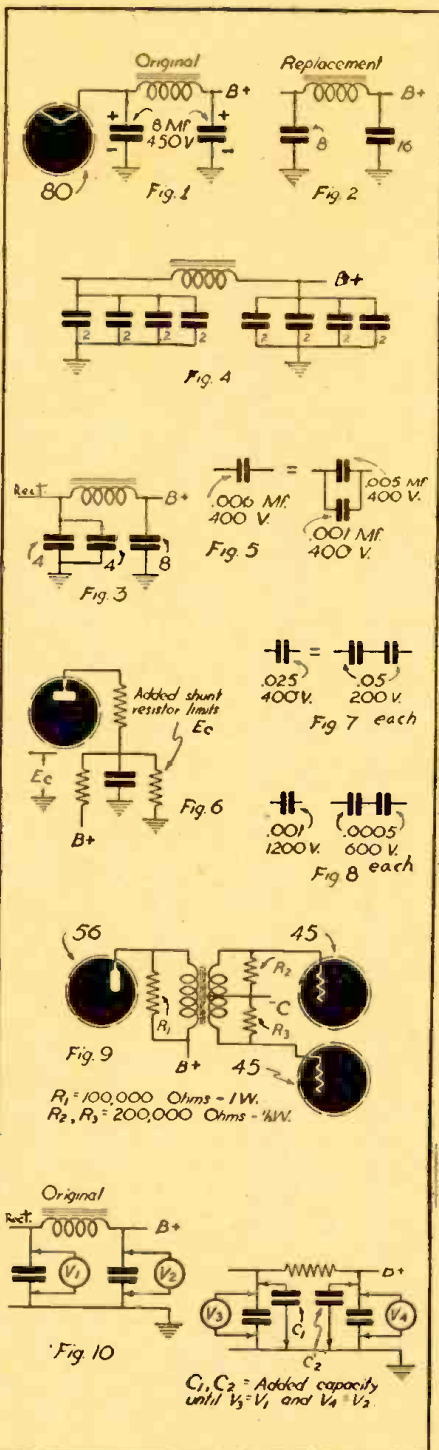

Fewer sizes of replacement condensers and resistors are available to the "war-time" Serviceman. In many cases he will find it necessary to substitute a couple of low-voltage condensers, connected in series, in place of a single condenser of higher voltage rating. Many interesting and practical problems concerning substitute resistors and condensers are discussed by the author and shown in the accompanying diagrams.

If we had had a number of condensers, each of 2 mf. capacity and 450 volt rating, it would have been perfectly feasible if not economical, to connect a number of them in parallel. (Fig. 4) Two 4 mf. condensers in parallel are equivalent to one 8 mf. condenser. Two 16 mf. condensers in parallel are equivalent to one 32 mf. condenser.

Probably the most common trouble will be in getting condensers of odd sizes in the paper series. That is, a condenser of .006 mf. may be difficult to get. (Fig. 5) In such cases a .005 mf. in parallel with .001 mf. will give the necessary capacity. If a .012 mf. unit is needed for a critical tone control circuit, two .006 mf. units can be substituted.

In certain cases a .5 mf. condenser of 400 volts is needed to withstand the momentary peak voltage which is present in a circuit when the current is first turned on. The operating voltage may be only 160 or 170 volts when the set is operating, (Fig. 6) but a 200 volt condenser can't be used. When a circuit such as this is encountered, it is possible in many cases to shunt a resistor across the condenser to limit the voltage peak. As the voltage is high when the set is turned on, the current in the resistor will be high and the effect of the voltage will be cut down. The resistor can be determined experimentally for a given set, by connecting a high resistance voltmeter (5,000 ohms per volt or better) across the condenser. The peak voltage can be measured with a test capacity in the circuit and then a resistor can be tried and a new measurement made.

The capacity of two condensers in series is given by the formula,

$$\frac{1}{C_N} = \frac{1}{C_1} + \frac{1}{C_2} \dots \text{etc.}$$

For example, two .05 mf. condensers of 200 volts hooked in series would be equivalent to a .025 mf. condenser rated at 400 volts. (Fig. 7) Two .01 mf. condensers rated at 200 volts each would be equivalent, if hooked in series, to a .005 mf. condenser rated at 400 volts. (The voltage strain is divided between the two condensers.)

In the automobile sets there are condensers across the high voltage secondary which have small capacities but high voltage ratings. Where there is sufficient space it is permissible to hook a couple of 600 volt condensers in series (Fig. 8) to get 1200 volt equivalent ratings.

RESISTORS

Suppose that we have a cathode circuit requiring a 400 ohm resistor rated at 5 watts. We have on hand a 100 ohm unit rated at a ½ watt and a 300 ohm unit rated at 2 watts. We are to assume that the original unit in the circuit is a 5 watt unit, but that 2.5 watts is the actual power in the resistor. Since the power is 2.5 watts and the resistance is 400 ohms, the current is

From the formula $P = I^2R$,

$$I^2 = \frac{P}{R} \text{ and } I = \sqrt{P/R}$$

Then,

$$I = \sqrt{2.5/400} = .079 \text{ ampere}$$

$$.079 \times .079 \times 100 = .625 \text{ watt}$$

$$.079 \times .079 \times 300 = 1.875 \text{ watt}$$

Therefore, the $\frac{1}{2}$ -watt would need to be changed to a 1-watt resistor, or 2-watt resistor—depending on the ventilation. The 300 ohm unit would need to have a 4 or 5 watt rating. A wattage rating equal to twice the normal circuit power is standard, commercial practice.

A 6F5 tube requires a 100,000 ohm plate load resistor for a certain type operation of the tube. The original load was a 100,000 ohm $\frac{1}{2}$ watt type. Can a 1 watt carbon type be used as a replacement? Yes, since the increase is in the right direction towards higher rather than towards lower wattage. Can a wire-wound type be used? Yes, since the inductance of such a unit, even though non-inductively wound, would be negligible (audio).

I have a special form of line cord which has a tapped resistance of 40 ohms from one end. The total series resistance of the cord is 160 ohms. The current in the circuit is .3 ampere (typical A.C.-D.C. heater circuit). I have on hand a 40 ohm 10 watt resistor and a 120 ohm wirewound resistor having a rating of 20 watts. Can these resistors be used in place of the original line cord, provided the job of installation is done in a rugged, workmanlike manner?

First of all, the power in the resistor is for 120 ohms at .3 ampere,

$$P = I^2R = .3 \times .3 \times 120 = 10.8 \text{ watts}$$

The power in the 40 ohm resistance is,

$$P = I^2R = .3 \times .3 \times 40 = 3.6 \text{ watts}$$

Thus, it is definitely established that the 20 watt, 120 ohm resistor and the 10 watt, 40 ohm resistor could safely be used as a replacement for the special line cord.

Suppose that we have two 1 watt resistors of 300 ohms and wish to know if they may be substituted for a resistor of 600 ohms and 2 watt rating. The power in the circuit is 1 watt. Since the power is 1 watt, the current is

$$I = \sqrt{P/R} = \sqrt{1/600} = .04 \text{ ampere}$$

$$\text{then } 300 \times .04 \times .04 = .48 \text{ watt}$$

$$\times 2$$

.96 watt total

The resistors, obviously, could safely be used.

If we have two 250,000 ohm resistors and one 50,000 ohm resistor, what is the net resistance if the resistors are all connected in parallel? From the formula,

$$\frac{1}{R_N} = \frac{1}{R_1} + \frac{1}{R_2} + \frac{1}{R_3}$$

$$\frac{1}{R_N} = .000004 + .000004 + .00002$$

$$\frac{1}{R_N} = .000024$$

$$R_N = \frac{1}{.000024}$$

$R_N = 35,714 \text{ ohms}$

I have an audio transformer with a burned out primary. The unit is used to couple a 56 plate to two type 45 tubes in push-pull. How may I make a repair which will give fairly good service without replacement or redesign? A simple way of doing it is to shunt a 100,000 ohm 1 watt resistor (Fig. 9) across the primary and to connect a .05 mfd. 400 volt condenser from the 56 plate to one of the 45 grids. By auto-transformer action, the second 45 grid will receive an audio signal. Since the pri-

mary of the transformer is open, the secondary impedance will be higher than it should be. Therefore, shunt a 200,000 ohm resistor across each half of the secondary.

I have a burned out speaker field having a resistance of 500 ohms. The set is an A.C.-D.C. job using a 25Z5 rectifier. The only replacement I can get is a 3,000 ohm (field) speaker. How should I connect the set?

Substituting a resistor of 500 ohms for the speaker field, a voltage measurement is made on the set and a reading of 16.5 volts is obtained. The power in the field must, then, be

$$P = \frac{E^2}{R} = \frac{16.5^2}{500} = .5245 \text{ watts}$$

The power in the 3000 ohm field is

$$P = \frac{E^2}{R} = \frac{16.5^2}{3000} = 3.3 \text{ watts}$$

The current is

$$I = \sqrt{P/R} = \sqrt{3.3/3000} = .0332 \text{ amp.}$$

The current in 500 ohms is

$$I = \frac{E}{R} = \frac{16.5}{500} = .033 \text{ amp.}$$

The currents are the same, but the powers are widely different.

Since the original speaker field power was .5245 watts and the speaker, having a 3000 ohm field, draws an excessive amount of current, what is to be done?

Adding another rectifier tube would be the only practical answer. At 100 volts output, the field would receive more energy than the original field received from its power source. However, the new speaker would have more reserve strength and greater power-handling capability, so that better tone would probably result when the heavier speaker field is used.

A choke coil would be used in place of the original field or a resistor could be used. If the resistor is employed, additional filter capacity will be needed to keep the hum-level down, due to loss of filtering action with the speaker field removed, or the choke inductance replaced by the low impedance resistor. The choke or field would have a high reactance and high impedance for A.C.—much greater than that of a resistor.

A quick way of checking the relative efficacy of the filter with resistance of 500 ohms in place of the 500 ohm field would be to use a vacuum-tube voltmeter or A.C. voltmeter across the second filter condenser. A voltage measurement of A.C. is first made, (500 ohm choke) A.C. voltage being checked across the first and second filter condensers. The 500 ohm resistor is then substituted and the A.C. voltage across first and second filter condensers is again checked. The second and first filter condensers are then shunted with additional capacity until the A.C. voltage appearing across the second filter condenser is no larger than the voltage which appears across the second filter condenser when the choke is used.

In some cases it may be necessary, due to the impossibility of obtaining a special transformer, to substitute a standard power transformer for a tapped transformer. Some sets, not many, use a 1-V rectifier and tapped secondary winding on the transformer. A type 80 rectifier can be substituted, with an improvement in hum reduction since for the same amount of capacity the full wave rectifier system has less hum output. The hum frequency is twice the power supply frequency, or 60×2 is 120 cycles. Condensers have $\frac{1}{2}$ as much reactance at 120 as at 60 and so they are more efficient by-pass agents.



MR. JOHN GEO. COLEMAN
 Radio Maintenance of Westchester
 110 Mt. Vernon Ave., Mt. Vernon, N.Y.

"N.U. products have always been of the highest quality. The N.U. Plan has helped me get those much needed pieces of testing equipment."

WHERE YOU FIND
NATIONAL UNION
 YOU FIND BETTER
RADIO SERVICE

PREMIUM
Quality
TUBES



BATTERIES



CONDENSERS

also *Transmitting tubes, panel lamps, cathode ray tubes, exciter lamps, sound equipment, photo electric cells, sound accessories, dry batteries, flash light bulbs.*

NATIONAL UNION invites . . .

All radio service dealers to enjoy the benefits of the N. U. Shop Equipment Plan. The latest in tube testers and test equipment are available to you . . . prompt delivery. More than 60,000 completed deals prove the success of this plan. Investigate now.

Ask Your N. U. Distributor or Write



NATIONAL UNION
RADIO Corp.
 57 STATE ST., NEWARK, N. J.

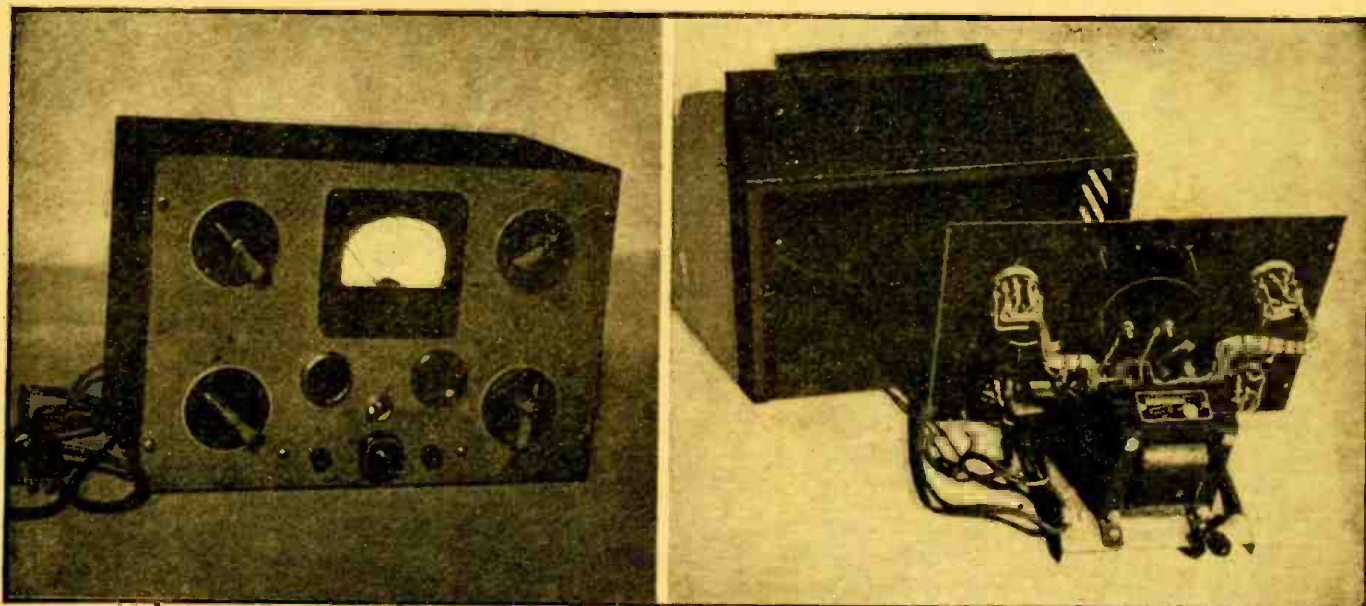

The photos above show front and rear views of the home-made line voltage "booster."

A LINE VOLTAGE-BOOSTER

With 4-Range A.C. Voltmeter

In many localities the line voltage rises and falls periodically, making the testing of the radio set a very dubious matter. The line voltage "booster" here described will be found most useful for correcting the voltage to the proper value.

LIONEL HAID

the two instruments. The construction of the instrument is here described.

The first thing to do is to secure all of the necessary parts. Next, lay out and drill the front panel as in figure 1. Mount the auto-transformer on the chassis deck, as far back as it will go. Then fasten the deck to the panel by means of two 6-32 round-head screws. Next mount all of the remaining parts on the panel. We are now ready to begin the wiring. A much neater job will be had, if all of the wires are grouped and tied with string. The multipliers furnished with the A.C. voltmeter come mounted in a perforated metal box $6\frac{3}{4}$ " long, $5\frac{1}{2}$ " wide and $3\frac{1}{2}$ " deep. This box is bolted with small screws to the back of the Bud metal cabinet. The meter selector switch is connected to the terminals on the multiplier

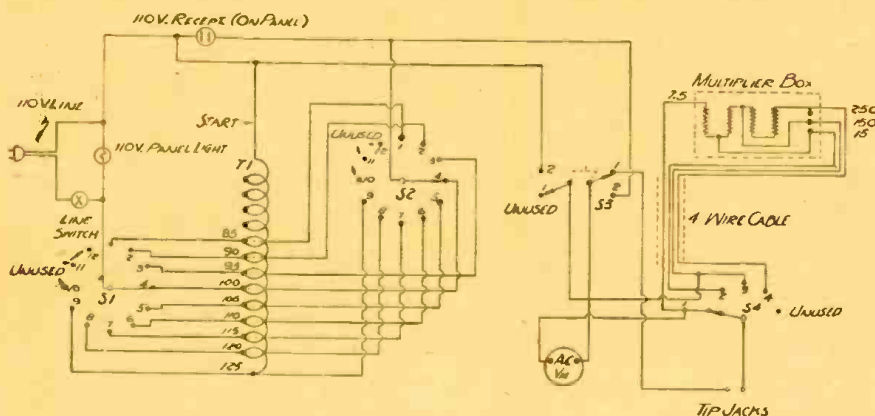

Wiring diagram for the easily-built line voltage "booster" is shown above.

Right—Panel layout diagram for the voltage "booster."

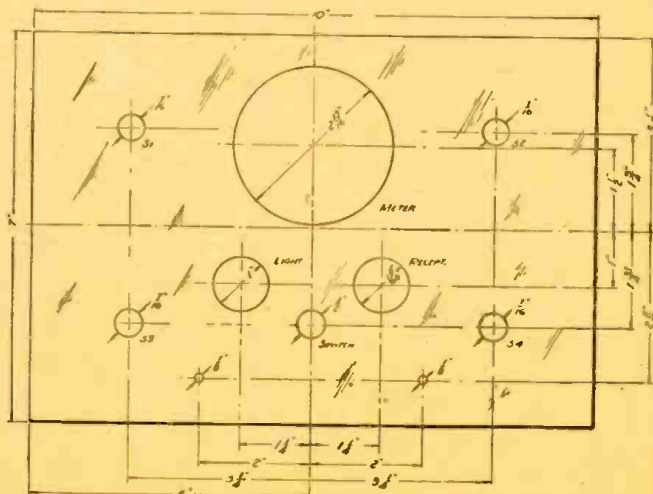

In the writer's locality (Indiana) we have had considerable trouble in the rural districts with intermittent operating sets. The steady flow of sets into our service shop with this complaint seemed to indicate that there was some trouble in the locality where these sets were used, especially when they would play perfectly for hours on our bench. To arrive at the source of the trouble, periodic checks of the line voltage in the customer's homes throughout the day were made, and we found that at certain times when there was the least load on the lines, the line voltage soared as high as 135 volts.

As it was impossible to work on the receivers in the home it was decided that we should design and build a suitable instrument for boosting the normal city line voltage to that equal to what the set must operate on. As we had no good A.C. voltmeter in the shop it was planned to combine

box by means of the four-wire cable. In our instrument we used a male and female connector plug in this cable, so that it could easily be removed from the cabinet. However this is not necessary if one desires to eliminate it. When all wiring is completed and you have rechecked with the circuit diagram, the panel may be fastened into the cabinet and the line cord plugged in the 110 volt A.C. outlet.

The two top switches are the voltage selector switches. By manipulating these switches, any desired voltage from 85 to 150 may be secured. The bottom switch at the left connects the meter to the tip-jacks, for external use when thrown to the left, and in the right position indicates the exact voltage being applied to the set. The switch at the lower right is the meter-range switch, effective only when the left switch is set for external use.

To test the instrument, set the voltage selector switches at any position, turn the meter switch (lower left) to the right. Now turn instrument on; the panel indicator light should glow and there should be a voltage reading on the meter. By manipulating the two top switches a wide variety of voltages will be obtained. If this gadget is carefully constructed the builder will be more than repaid for his investment in money and labor, as many intermittent troubles can be easily located and remedied.

Since sending you the details of the booster, I have added a flasher mechanism which I wired in series with one side of the 110 volt line. I used a rotary switch in parallel with the flasher to "short" it out when not in use. This switch accounts for the large black knob at the lower center of the front panel in these later pictures. The flasher is a heavy-duty adjustable device from an old electric sign that I found in the conglomeration of odd parts that I have accumulated. I find that by flashing the set on and off while it is under test, will often show up "intermittents" that will not show up when merely tested on an increased voltage. As this flasher is adjustable, I can set it for any period of off and on contacts that I desire, up to half minute intervals.

Incidentally, the booster makes a dandy soldering iron control when not being used for the purpose for which it was intended. By setting the controls for about 80 volts the iron can be left on for long periods without "burning up".

LIST OF PARTS

- One Stancor No. P-5068 Auto-former
- One Bud No. C-993 Metal Cabinet
- One Bud No. CB-522 Chassis Deck
- One Bud No. JL-1698F 110 V. Lamp and Socket
- One Triplett No. 337A A.C. voltmeter with multipliers
- One Amphenol No. 61-F A.C. receptacle
- Two Yaxley No. 32112J 12-point tap switches
- One Yaxley No. 3215J 5-point tap switch
- One Yaxley No. 3222J S.P.D.T. switch
- One Amphenol No. MPM4 male cable connector
- One Amphenol No. MPP4 female cable connector
- Two Centralab 1-5 numbered switch plates
- Two Centralab 1-10 numbered switch plates
- One toggle switch
- Two Amphenol tip jacks No. 78-1P
- Three feet of four-conductor cable
- Six feet of rubber-covered line cord
- One line cord plug

What Say — Servicemen?

Got A Good Idea for War-Time Servicing?

Send a sketch . . . we redraw them . . . together with a description . . . typed if possible. All articles accepted and published will be paid for at regular rates.



NOT A SUBSTITUTE!

...It's a Super-Rugged Sprague "Dry" Specially Built to Do a Wet Electrolytic Job

Same diameter as wets

Specially made to stand high voltage peaks

Handles AC ripples that standard 450 V. Drys cannot

WARTIME restrictions make it difficult to supply wet electrolytic condensers because of their aluminum thread-neck cans—but, thanks to Sprague engineers, you can keep right on making wet electrolytic replacements, and do it with the same assurance as though you were using the finest wet electrolytic condensers ever built.

The answer is the new Sprague Type WR Replacement Capacitor—a tubular cardboard dry electrolytic of very high voltage formation. Not only will WR's stand the peak voltages often impressed on wet electrolytics, but they'll handle

the AC ripples that might cause standard 450-volt dry electrolytics to overheat to the point where they break down. The diameter of WR's is the same as that of standard wets so that they will fit the screw-type can mounting holes. Their metal feet can then be soldered to the chassis for firm mounting.

Sprague Type WR's are now available in three sizes—WR-8 which replaces wets from 4 to 8 mfd.; WR-16 to replace capacities from 12 to 18 mfd., and WR-25 to replace capacities from 20 to 40 mfd. Ask your Sprague jobber today!



WARNING! Don't be fooled! Although standard dry electrolytic condensers can sometimes be used as wet replacements, your safety margin is apt to be mighty thin. High surge voltages and AC ripples may cause trouble. That's why it pays to play safe by using the new Sprague WR Types. They're not substitutes. They're actually built to do a wet electrolytic job. They're the real thing as far as performance and durability are concerned.

SPRAGUE WET REPLACEMENTS
(SPECIAL WR TUBULAR DRIES)
SPRAGUE PRODUCTS COMPANY, North Adams, Mass.

Radio Plane Guide

A TWO-COURSE ultra-high frequency radio range development of a type which is expected to replace the radio beam system now in use on the airways of the United States within the next few years was described at the winter convention of the Institute of Radio Engineers.

The new development operates on 125 megacycles, a wave length 400 times shorter than the wave length in use at present. Experimentation indicates that this ultra high frequency system eliminates static entirely and greatly diminishes the danger of multiple courses and the distortive effects which mountains, rivers, ore deposits and other influences of terrain exert upon radio beams, factors which have been held responsible for airline accidents. The new system provides precise and complete information to the pilot. It shows him whether

or not he is to the left or right of his correct line of flight and whether he has flown beyond the radio range station or has not yet reached it, an extremely important point of information in bad weather.

The ultra high frequency range has been developed for and in collaboration with the Radio Development Section of the Civil Aeronautics Administration by the Laboratory Division of the International Telephone & Radio Manufacturing Corporation.

In addition to its safety factors and more complete information for the pilots, the new development points the way much further toward the automatic gyroscopic control of the plane. The instrument indicator actuated by the ultra high frequency range transmitter may in the future be used to direct the automatic pilot and thus keep the plane on its course automatically.

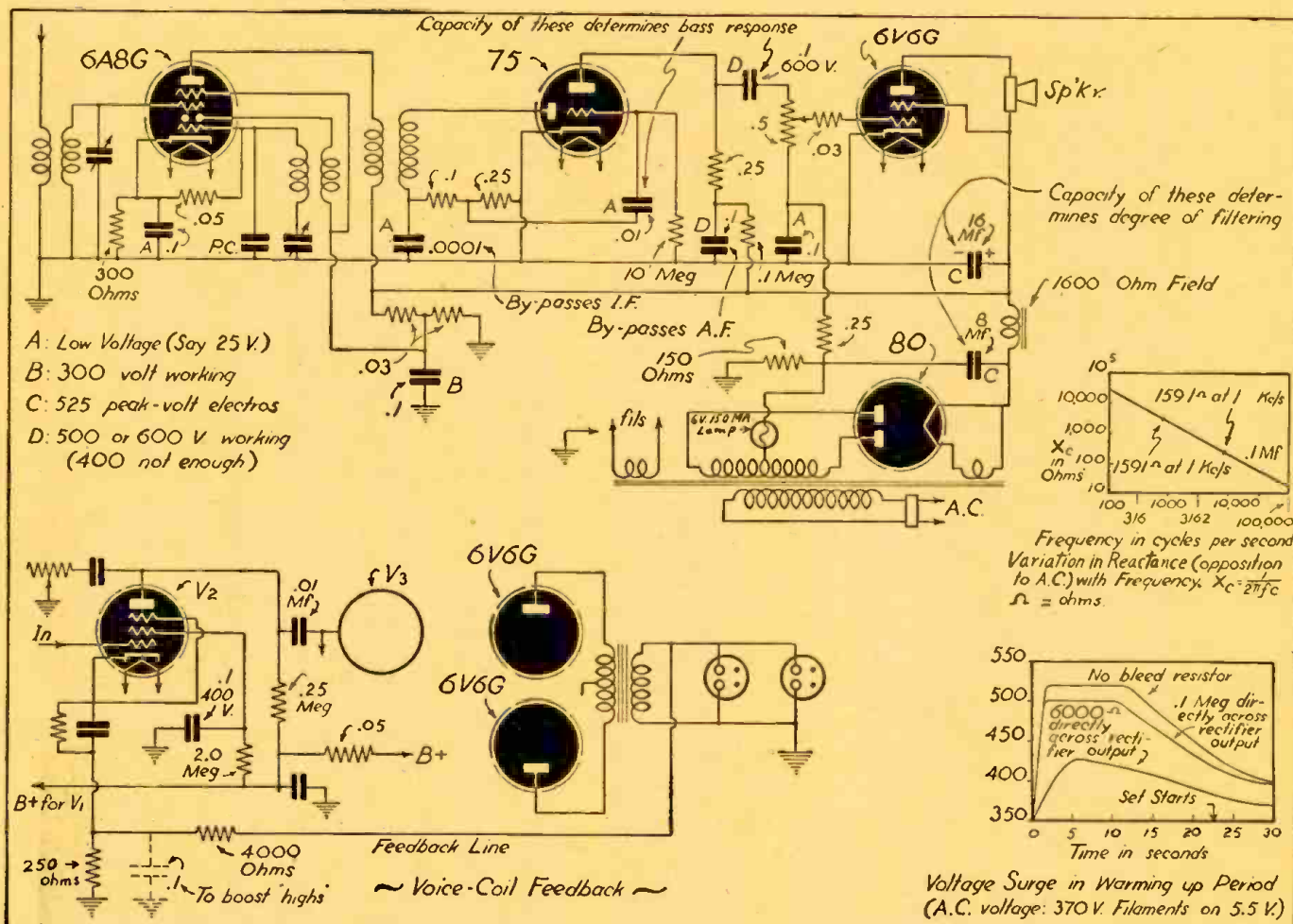

This circuit diagram, in connection with the text, gives a clear idea of the voltage ratings of condensers and at what points units with lower ratings may sometimes be substituted.

What Condenser Ratings Mean

JOHN W. STRAEDE, B.Sc.

CONDENSERS are usually labelled with their capacity in microfarads and their safe working voltage. Sometimes a test voltage is also mentioned in the case of tubular condensers or a maximum peak voltage in the case of electrolytics. The test voltage should be at least three times the working voltage and is usually greater still.

VOLTAGE RATINGS

For electrolytics, working voltages of 450 and 500 with peak voltages of 500 and 600 are common, but a "450-volt working" electrolytic may deteriorate rapidly (a sign of overloading) when the working voltage is only 400 volts. The reason, of course, is that the peak voltage across the condenser may be as high as 530 volts in the period before the set "warms up." Another factor not always realized is that when a condenser is connected to a pulsating-voltage supply, the peak voltage is much greater than the R.M.S. (root-mean-square) or effective voltage, depending on the nature of the fluctuations. For full-wave rectified A.C., the peak voltage is 1.414 times the final "smoothed" voltage, assuming the original A.C. was a pure sine-wave alternating current. The peak D.C. voltage cannot be greater than 1.414 times the original A.C. voltage, so an electrolytic of 525 peak-volts rating will work quite as well after a high-

The author answers such practical questions as—Why higher voltage condensers must be used in filters connected to a vibrator; what the relation of the peak value of the voltage is to the R.M.S. value; why screen-grid circuits are tough on condensers, etc.

voltage-output 5V4G as after a less-efficient "80," provided the A.C. applied to the anode or plate is of the same voltage.

PEAKS WITH VIBRATORS

The output of a vibrator, on the other hand, has enormous voltage peaks, and the first filter condenser may require to be 1,500-volt or 2,000-volt working. (The test voltage should be much higher, say, 4,000 to 5,000 volts.)

When a set is switched on, the tubes take several seconds to warm up, and during this time the voltage across the electrolytics may rise above their rated value. In practice, there is generally some resistor across the H.T. supply (a "bleeder" resistor), which draws current at all times, the output tubes may be directly heated and so draw current immediately, or the rectifier may be indirectly heated.

But, apart from this, the condensers take a certain time to charge, and during that time they draw current (apart from leakage current), so the actual rise in smoothed voltage is not to 1.414 the original A.C. value but to about 1.1 or 1.2 times, depending on the actual circuit. Again, wet electrolytics are to a certain extent self-healing and are less damaged by overloading—in practice, a 500-volt wet electro. seems just about equivalent to a 525-volt dry one.

Check up on your pet circuit or your own hi-fi super-bloopydyne to see if one, two, three or more of the following features are present to prevent overloading of the electrolytics: (1) Indirectly heated rectifier; (2) bleed resistor; (3) directly heated output tubes; (4) high-voltage electros (600-volt type).

LEAKAGE RESISTANCE

The voltage rating of a paper type condenser is also an indication of its leakage resistance. To withstand high voltages, three layers of waxed paper may be used as the dielectric, thereby reducing the leakage resistance.

Another place where condensers break down is when used to by-pass screen voltages. Suppose the screen-grid of a resistance-coupled 6J7 requires 40 volts. You might suppose that a 200-volt condenser would be O.K. So it might be, if the voltage

came from a divider, but if a dropping resistor is employed, then the condenser will certainly break down, because there is no voltage drop across the resistor when the set is switched on (and the 6J7 is cold), and the full H.T. voltage (then at its highest, say, 500 volts) is across the screen by-pass condenser.

Sometimes condensers are connected in series to increase the voltage rating. This is very satisfactory in the case of wet electrolytics. For other types, bleeder resistances (about .1 meg. 1-watt or .25 meg. 1/2-watt) should be connected across each condenser to equalize the voltages. The catch, of course, is that if two equal condensers are connected in series, the capacity is halved. Two 8 mf. 500-volt condensers in series give a 4 mf. 1,000-volt combination.

CAPACITY RATING

The use of a condenser depends on its ability to store small amounts of electricity, the amount stored depending on the voltage across the condenser and its capacity. We say that A.C. passes through a condenser—what really happens is that the charging and discharging of the condenser permits the A.C. to keep flowing. D.C. (apart from a momentary surge, when the condenser becomes charged) does not pass through a condenser, so a common use of a condenser is to separate A.C. from D.C. *Smoothing* condensers across the H.T. supply by-pass the A.C. portions or the "ripple." The D.C. passes to the set.

The "reactance" or opposition of a condenser to A.C. depends on the size of the condenser and the frequency or rate of variation of the A.C.

To separate A.C. and D.C., the condenser should be as large as possible. In practice there are limits, the physical size and the leakage generally increasing with capacity.

RADIO FREQUENCY

High-frequency alternating currents (R.F.) pass more readily than low-frequency (A.F.), so a condenser may be used to separate them. The size of the condenser here is important. If too large, too much A.F. gets through with the R.F. If too small, only part of the R.F. gets through, the remainder continuing with the A.F. In other words, there is always an "optimum size." A classical example of this is the condenser across the grid-leak in a grid detector circuit. For many years this was .00025 mf., which by-passed some of the higher audio-frequency signals. When the demand for quality slowly arose, like some dinosaur dragging itself out of the primeval mud, people began to demand these "highs" and the condenser was reduced to about .0001 mf. with a slight loss of volume, because part of the R.F. did not "get through."

RESISTANCE-CAPACITY COUPLING

Because the reactance of a condenser varies with frequency, resistance-capacity coupling between tubes tends to weaken the low notes. The actual loss at any frequency depends on the size of the coupling condenser and the size of the grid resistor. The product of these two values (one in mfd., the other in megohms) gives an indication of the fidelity. The reciprocal of this product indicates the frequency at which response starts to fall off. (The response is approximately 3 db. down at a frequency six times the reciprocal, e.g., if $C = .002$ mfd., $R = .5$ meg., then the reciprocal is 1,000. The response is 3 db. down at about 150 c/s.) The circuit shown has a total loss of less than 1 db. at 20 c/s. from diode load to output, excluding speaker losses.—Reproduced through the courtesy of *The Australasian Radio World*.

PROTECT that 40%

Now more than ever the jobber and service man must protect the standing which he has built. Condenser replacements account for about 40% of all radio repair jobs. Dependable condensers are therefore essential to the building of the utmost in customer satisfaction and in holding your clientele.

CONTINUOUS DEPENDABLE SERVICE

For 21 years the manufacturers of POLYMET electrolytic and by-pass condensers have striven to improve quality and service. Add to this a liberal and reasonable mark-up and the fact that no fly-by-night "bargain catalogs" can undersell you on POLYMET. You're protected, your customer is satisfied, your profits and volume increase. We're conserving vital defense materials by limiting sizes to those most universally used. These will serve practically every need, repairing larger electrolytics when proper capacity and voltage are used.

Complete listing of available types and prices will be forwarded upon request.

POLYMET CONDENSER CO.
699 E. 135TH. ST., NEW YORK, N.Y.

DIATHERMY MACHINE USED BY SPIES

The use of short-wave diathermy machines (of the type used by physicians for treating human ailments) by spies in wartime was described in considerable detail by H. Gernsback in his editorial in this magazine for May, 1940, page 645. In that article Mr. Gernsback also described an effective means for shielding the short-wave diathermy apparatus, so that it could not radiate electrical waves.

This editorial also pointed out that short-wave diathermy machines had been known to cause a radio disturbance 3,000 miles away and even further.

In a recent feature article published in the *New York Daily Mirror*, all of these facts are once more brought to the attention of the public. The claim is made by this newspaper that a checkup by government agents has shown that Jap "Fifth Columnists" were using a whole series of these diathermy machines to transmit data on ship sailings, etc., to Japan. The article also claims that a very ingenious scheme was utilized to synchronize a dozen or more of these machines, so that they would all operate as one powerful transmitter, and at the same time make it much more difficult for F.B.I. radio listeners to locate exactly the origin of the secret signals.

One thing is certain—our government authorities should pass a law requiring that all short-wave diathermy machines be licensed, or else carefully and minutely checked up by F.C.C. inspectors. Every machine of this type to be placed within a metal shielding cage, or else a room whose walls are covered with wire mesh or screen, and the screen thoroughly grounded.

It is interesting to point out that investigations made a few years ago showed that it is not sufficient to place a single wire-screen cage around such a diathermy machine, but that to positively eliminate any radiation of radio waves from the apparatus, that it is necessary to use two wire-mesh screens or cages, the two cages or screens separated a few inches apart, and both of them thoroughly grounded.

4 STANDARD TYPES

of Amperite Regulators replace over 400 types of AC-DC Ballast Tubes now in use.

Amperites are real REGULATORS... have patented Automatic Starting Resistor which prevents initial surge and saves pilot lights... Ask Your Jobber.

AMPERITE

THE *Simplest* WAY TO REPLACE **BALLASTS**

WRITE FOR REPLACEMENT CHART

AMPERITE CO. 561 BROADWAY, NEW YORK, N. Y.

RADIO TECHNOLOGY

RCA Institutes offer an intensive course of high standard embracing all phases of Radio and Television. Practical training with modern equipment at New York and Chicago schools. Also specialized courses in Aviation Communications, Radio Servicing and Commercial Operating. For Free Catalog write Dept. RC-42.

RCA INSTITUTES, Inc.
A Radio Corporation of America Service
75 Varlek St., New York. 1154 Merchandise Mart, Chicago

How I Service

"PERSONAL RADIOS"

In Institutions

FLOYD D. GOFF

AS I am located near a large sanatorium and several educational institutions, I am often called on to service *personal radios* in them. A serviceman working in places of this type will often run into problems and situations very seldom experienced in ordinary service work. I wish to describe here a few of my experiences and methods.

It is true that about seventy percent of the personal radios in use in these places are of the A.C.-D.C. type. Many servicemen consider servicing them unprofitable but my carefully kept records show that this is untrue. Due to the voltage fluctuation caused by the present heavily loaded conditions of the power systems, you can realize a nice profit from tube replacements alone, in them. Another thing, due to the increased list prices you are less likely to hear the remark "Why that is more than half the cost of the entire radio," when presenting your bill. If you are within reach of any institutions of any kind, you will do well to make yourself known and appreciated in them.

A good way of advertising in hospitals and sanatoriums is to have some gummed stickers printed with your complements and address. Put them on the covers of some of the more popular five cent weekly magazines and distribute them through the different wards, lounge and sun rooms.

One of the biggest troubles with radios in this type of place is interference. No one will expect you to completely eliminate interference in a place like this but they will ask you to reduce it. I have found that it originates mostly in the power line, so it is fairly easy to bring down within tolerable limits. One filter may work wonders in a certain room but be practically useless in the next room or across the hall. The only thing you can do is try several different filters until you find the best one. Sometimes a large filter will be of little value to a certain set, while a simple 1 mfd. by pass across the power line will almost completely eliminate the interference.

When I use an ordinary condenser across the power line I always put it underneath the chassis if possible. However in some of the tiny, midget sets this is impossible. In these cases I attach it to the power cord just back of the plug, with a neat layer of white adhesive tape. Then I put on a layer of Scotch cellulose tape to keep it from getting dirty.

As all servicemen are familiar with the different ways of eliminating interference in power lines it is useless to give any further description here.

Most people in institutions of this type want earphone jacks on their receivers.

Many unusual problems are encountered in attempting to service small radio receivers in hospitals and other institutions; how the author solved some of these problems is here explained.

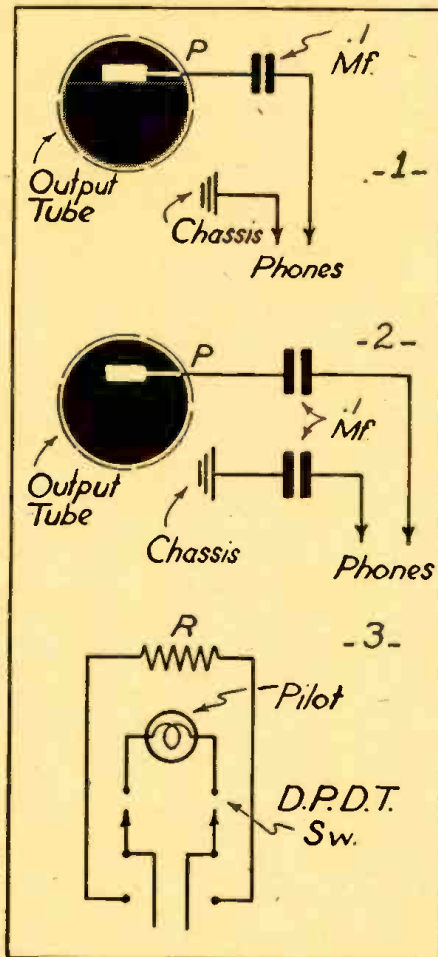

Two top diagrams show how to connect phones to radio set; lower diagram pilot lamp "cut-out" switch.

There are several methods of installing these but I have found that the methods shown in Figures 1 and 2 usually give the best results. When installing earphone jacks always use an open-circuit jack (Utah type 2-A or similar). Connect it so that it open-circuits

the voice coil when the phone plug is inserted. This eliminates the need of a switch.

In places where all lights must be turned out at a certain hour they will also want a pilot light switch. In some cases a single-pole switch is all that is necessary but where the pilot light acts as a ballast I use the method shown in Figure 3. The resistor is a 5- or 10-watt unit of the same value as the pilot bulb resistance.

Most sets you will find in use in these places have "built-in" aerials, but sometimes you will be asked to erect one. In places where there is an unusually large amount of electrical interference I find that a short length of bare copper wire, strung up inside the room *without insulators* of any kind will give good signal strength with less interference, than an aerial of the conventional type. In fact the results of some experiments I made along this line were amazing. It seems that the high resistance path to ground has some kind of attraction for the charges of static, while the radio waves naturally take the path of least resistance. Of course no ground can be used with this type of aerial.

Most of the modern institutions have a house radio and public address system something similar to the school systems except that earphones are used instead of loud speakers. Many of your customers in these places will want adaptors so that they can listen to these entertainments and announcements through their radio speakers. The method of doing this needs little description as it is done in the same way that a phonograph is adapted to the audio section of a receiver. You can use either a transformer or condenser input to the audio grid circuit. A good quality transformer will usually give the best results.

It is a common thing for owners of small radios to decide to take them out of the cabinet and give them a "good going over." The result usually is that they tighten up all of the trimmers. Three times out of five they are reluctant to admit that they did anything to it. When you suspect that this has been done but not quite sure, the quickest way I know of to find out is the following. Turn the variable condenser plates completely in mesh. Connect a signal generator to the antenna post of the set (if it has a built-in aerial, disconnect it). Touch an .05 condenser to the *oscillator* grid of the first tube, holding it in the hand but not touching either lead. Slowly tune the signal generator from about 550 through 650 kc. If a signal can be heard at any point, no matter how weak then the circuit is all right except for alignment. This can be done more quickly than it can be described. This method can be used only on A.C.-D.C. sets.

Watch Out for Mice Saboteurs!

● ALL battery radios, particularly Crosleys, and all models having closely spaced variable condenser plates—(battery sets) in the country homes are often subjected to "investigation" by mice, and this condition leads to a very peculiar chemical action on the chassis and all exposed metal parts.

One very obstinate case of failure to operate in one of these battery sets had all the ear-marks of a burned-out antenna coil. Upon checking, it was found to be O. K. After much searching and fuming, I decided to clean the condenser plates with carbon tetrachloride, after which the set

functioned perfectly. It is impossible to detect a "short" between the plates when this condition occurs, but the signal is blocked off at this point. This tip should save anxious hours for the serviceman, as we often find traces of *sabotage* by mice on "town" sets.—Thos. F. Shambach, Jr.

Off the PRESS!

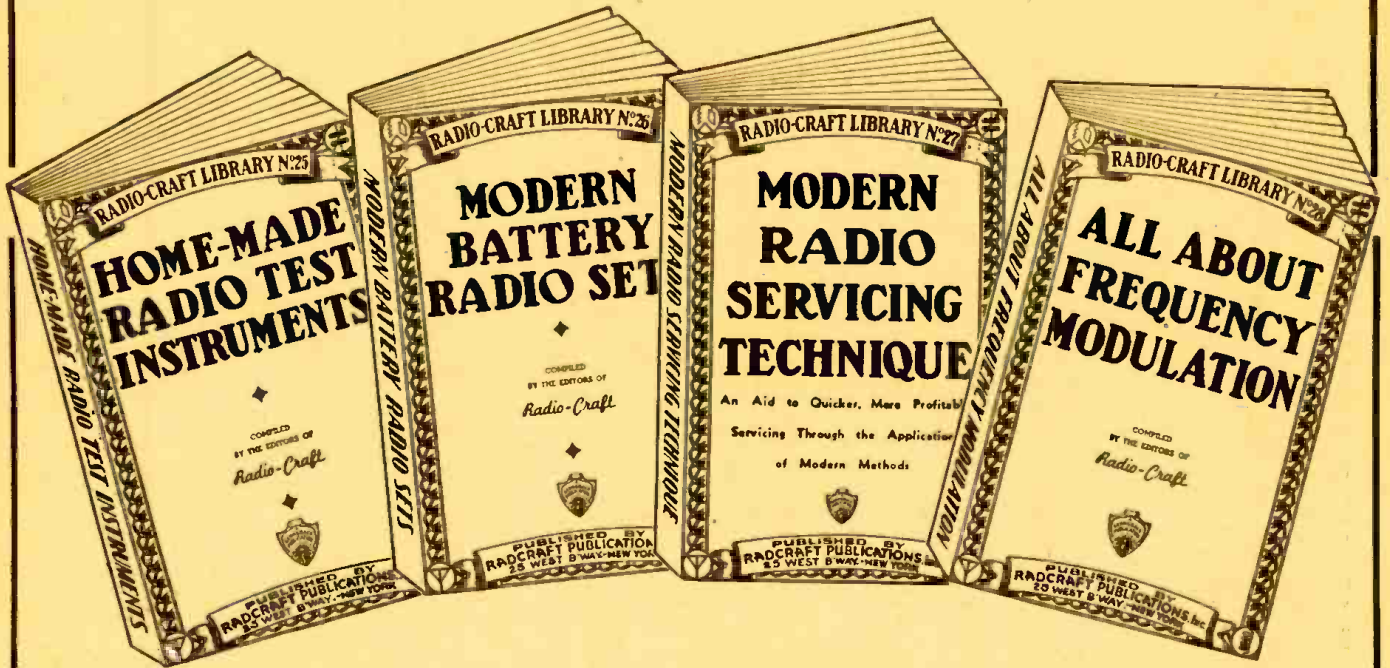

New RADIO-CRAFT Library Books

THE four latest books of our well-known RADIO-CRAFT Red Books—Nos. 24, 25, 26 and 27—have just come off the Press. These four books are all on timely subjects and we recommend every one of them to you strongly.

Now, more than ever, radio education has become a burning question. If you are to be in the National Service; in the Army, Navy or Air Force—practical radio knowledge is of paramount importance. **YOU CAN GET BETTER RATINGS AND ADVANCE QUICKER IF YOU HAVE A GOOD RADIO BACKGROUND.**

Conversely, if you are not with the armed forces, there is a whole of a job to be done at home. With more and more men going into the service, the demand for practical servicemen becomes greater each day. Therefore we say: **PROFIT BY THESE UNIQUE BOOKS, WHICH ARE PRICED SO LOW THAT THEY ARE WITHIN THE REACH OF EVERYONE'S PURSE.**

No. 24—AUTOMOBILE RADIO PRINCIPLES AND PRACTICE

A complete compilation of pertinent data on how to install and service the modern automobile radio receiver. All of the most-essential details which have crept into the profession have been weeded out. Each topic is treated so as to contain a precise statement of the fundamental principle involved, to assure the reader's clear understanding, without distracting his attention by the discussion of a multitude of details and mathematical expressions, which are primarily for the engineer; and tend to confuse rather than clarify a statement for the auto-radio-technician. A practical treatise based on practical experience by practical radio people for the practical radio-technician. This book contains 85 illustrations.

Outline of Contents: Introduction—The Auto-Radio Art—Features of the Modern Automobile Receiver—Installations of Automobile Radios and Antenna—The Automobile High and Low Tension Electrical Systems—Automobile Electrical Disturbances—Vibrator Convertors and Motor Generators—Service Hints, Classified Automobile Installation Notes, and Conclusion.

No. 25—HOME-MADE RADIO TEST INSTRUMENTS

This book includes articles covering a wide range of test apparatus of live interest to every radio man. Servicemen will find many circuits in this book to make their work more profitable. New ideas in test equipment make it possible to service radio receivers more quickly.

Laboratory workers and experimenters will find many articles which describe in detail construction and use of all essential radio test units—multi-meters, oscillators, stage-analysis testers, oscilloscope equipment, V.-T. voltmeters, etc. Even advanced technicians will be interested in the circuit arrangements showing the new and improved variations of well-known, basic test equipment. A MUST for every serviceman. This book contains 86 illustrations.

Outline of Contents: A Low-Cost Signal Chaser—Signal Tracer Test Unit—Simplified Practical Signal Tracer—A Home-Made Infinite-Resistance Tube Checker—Build This Direct-Reading V.-T. Voltmeter—How to Make a Modern V.-T. Voltmeter—Measuring High Values of A.C. Voltage and Current With a Low-Range Meter—How to Make a Meter-Range Extender—How to Build a Practical Tube Tester and Set-Analyzer Adapter—The Beginner's Simple Volt-Milliammeter—Build This Simplified Neon-Type Test Unit—Midwest Oscilloscope—How to Make and Use a Frequency Wobbler—Double Tracing Your Oscilloscope—Home-Made Frequency Modulator.

No. 26—MODERN BATTERY RADIO SETS

Whether you are a radio man or a beginner, the articles in this book give you basic circuit arrangements or elementary radio receivers which serve the dual role of teaching the elements of radio reception, as well as making perfectly operating 1- and 2-tube radio receivers. Picture diagrams and bread-board layouts galore.

Advanced radio set builders are offered more complicated arrangements. Laboratory workers and engineers will find in many of the articles circuit and constructional features which have become commercial practice. Many entirely new ideas are given in this book. One of the most important volumes we recently issued. This book contains 78 illustrations.

Outline of Contents: Beginner's 1-Tube High-Gain All-Wave Receiver—Beginners-Build This 1-Tube Loop Receiver—A "3-in-1" Battery Portable—An Easily-Built "Flewing Superregenerative" 2-In-1 "Card File" Battery Set—

A 2-Tube Superhet. With Pentagrid Regenerative 2nd-Detector—The 4-Tube Superhet. Vacation Portable—The "Lunchbox 5" Battery Portable—"The Seafarer" Loop-Type Boat Radio Set—4-Tube Permeability Portable—An All-Purpose Portable—A Typical Commercial 3-Way Portable (Pilot Models X-1452 and X-1453)—Switch for Varying "C" Bias on Battery Radio Sets—Making a Simple Portable Aerial—Making a Pilot-Light Fuse—Old Auto Sets for New Cars—Using a Loop Portable in Cars—Quasi-Electric Soldering Iron—Lamp Bulbs as Resistors.

No. 27—MODERN RADIO SERVICING TECHNIQUE

Here is a book of great importance to every radio man, every radio engineer, and particularly all radio servicemen. A list of the contents which follows shows the importance of this book, literally jam-packed to overflowing with radio-ment. Whether you are a servicing beginner or whether you are an experienced serviceman—you will find many important helps in this volume. Book is eminently practical and will solve many problems for you. More important: It will show you many short-cuts, all calculated to save your time and patience. Practical everyday data on standard receivers appears throughout the book. A whole of a book compressed into a minimum of space. Contains 93 important illustrations.

Outline of Contents: Elementary Servicing Technique—Correct Procedure for the Servicing Beginner—Elementary Procedure for Servicing Radio Sets—A.F.C. Alignment Made Easy—Dynamic Servicing—Dynamic Testing Simplifies Servicing—Modern Receiver Test Requirements—Servicing Universal A.C.-D.C. Receivers—Servicing "Orphans" and Private-Brand Sets—Emergency Servicing Without Test Meters—Servicing Coils—Servicing R.F. Coils—Servicing Oscillator Coils—General Information—RMA Transformer Color Code—What Causes Echo, Fading?—Radio Service Puzzlers.

SPECIAL SEND-NO-MONEY OFFER

It is not necessary that you send money with order. If you wish to take advantage of our C.O.D. plan, simply cut out the coupon, paste it on a post card and send it to us. Books will be sent to you immediately.

All four books are listed uniformly at 50c each. No discount on less than three books.

If you wish to take advantage of our special offer, ordering three books or more, we make an unusual low price to you as follows:

3 books—\$1.25
4 books—\$1.50

Do not fail to send coupon today!

RAD-CRAFT PUBLICATIONS, INC.
25 West Broadway, New York, N. Y.

Radcraft Publications, Inc.,
25 West Broadway,
New York, N. Y.

Gentlemen:

Rush to me by return mail, as per your special offer, the following books: (Check books selected.)

No. 24—AUTOMOBILE RADIO PRINCIPLES AND PRACTICE.
 No. 25—HOME-MADE RADIO TEST INSTRUMENTS.
 No. 26—MODERN BATTERY RADIO SETS.
 No. 27—MODERN RADIO SERVICING TECHNIQUE.

I will pay postman 50c for each book, (if two, or one only are ordered) plus a few cents postage and charges. \$1.25 for three books, plus a few cents postage and charges. \$1.50 for four books, plus a few cents postage and charges.

NAME

ADDRESS

CITY STATE

Save shipping and C.O.D. charges! Check here if you send cash with order. (Cash, U.S. new postage stamps, money order, check.) Foreign countries no C.O.D. Add 20% to all prices quoted.

PILOT Model 340 SERIES
110 Volt A.C.-D.C. Receiver Service Data

TUNING RANGE

Broadcast Band—	535 to 1730 kc. or 560 to 173 meters
Short Wave Band 2—	1.75 to 5.85 mc. or 171 to 51 meters
Short Wave Band 1—	7.0 to 22.0 mc. or 43 to 13.6 meters
49 meter Band —	5.9 to 6.22 mc.
31 meter Band —	9.5 to 9.7 mc.
25 meter Band —	11.68 to 11.92 mc.
19 meter Band —	15.06 to 15.38 mc.
16 meter Band —	17.62 to 17.98 mc.

This Pilot Superheterodyne Receiver has 10 tubes and a Cathode Ray Tuning Beacon, and operates on either an Alternating or Direct Current power supply.

HOW TO OPERATE

IMPORTANT: Before putting the receiver into operation, remove the four red packing screws under the cabinet and two steel brackets located under the chassis. The chassis will then float freely on the rubber cushions, insuring reception free from vibration.

ANTENNA

While this receiver will give excellent results with a few feet of wire for an antenna, you will be well repaid for the slight expense of a good antenna by the improvement in tone quality, the distance from which foreign stations may be received and the reduction of interfering noises due to other electrical devices. For short wave or distant broadcast band reception the use of a doublet external antenna is recommended.

When using a doublet antenna, connect one lead-in wire to terminal "A" at the rear of the chassis, and the other lead-in wire to terminal "D." Remove the connecting link from terminals "D" and "G" and connect terminal "G" to a ground such as a cold water pipe or radiator. If an ordinary single wire antenna is used, connect the lead-in wire to Terminal "A" on the rear of the chassis. Leave the link between "D" and "G" terminals and connect a ground wire under terminal "G." A doublet antenna kit complete with all accessories is available.

POWER SUPPLY

This receiver will operate on 105-125 volts or 200-240 volts as indicated on the locking plate in the rear of the chassis. To change operating voltage, remove locking plate, move switch to other position and replace plate.

When operating on direct current, if the receiver does not work about one minute after being turned on, reverse the plug in the light socket.

CONTROLS

There are three knobs and eight push-buttons for control of this receiver. The purpose of the knobs is indicated on the front of the cabinet. The push-buttons select the desired wave band.

The "ON" and "OFF" POWER SWITCH and VOLUME CONTROL is at the extreme left. To put the set in operation, turn this knob to the right. After the tubes have warmed up, turn the knob further towards the right to increase the volume.

The second knob from the left is the TONE CONTROL. The tone quality of the receiver may be adjusted by turning this control to the left to emphasize the bass notes, to the right for full, well-rounded tone.

The TUNING CONTROL is the extreme right hand knob. With this control any part of the range on which the band switch is



The Pilot Model No. 340 A.C.-D.C. receiver, covering the short wave and broadcast bands.

set may be tuned. By incorporating the use of a Gyro-Spinner the tuning over the full range has been facilitated. Careful tuning of this control is most advantageous on the Short Wave Bands.

The PUSH-BUTTONS are used to select the desired band as indicated above each button.

CATHODE RAY TUNING BEACON

Any station must be accurately tuned in, as the careless adjustment of the tuning will cause distortion. The Cathode Ray tuning beacon in the top center of the dial scale shows when the receiver is accurately tuned to the station's signal. As the station desired is approached by the pointer, the unlit inverted "V" shaped sector of the Cathode Ray tuning beacon will get smaller. When the correct setting of the station is passed by the pointer, the unlit sector will increase in size. The correct setting for the full volume of the station's signal is where the sector is smallest. The sector will completely disappear on a powerful signal.

PHONOGRAPH AND TELEVISION JACKS

On the rear of the chassis is a set of "Pin" jacks. They are intended to be employed for connection with an electrical phonograph, or with the sound outlet of a television receiver.

BAND SPREAD TUNING

The International Short Wave Broadcast Bands have been spread out over the full dial length to make the tuning in of foreign broadcasts as easy and accurate as the local stations on the broadcast band.

In the morning and during the day best results may be expected on the 16 and 19 meter bands. In the late afternoon 25 and 31 meter bands are better and at night most stations may be heard on the 31 and 49 meter bands.

SERVICE NOTES

The location of all adjustments used in re-aligning this receiver, and the frequencies at which these adjustments should be made, are shown in the accompanying diagram.

When aligning the I.F. amplifier, the generator must be connected to the grid of the 6SA7 tube through a .1 mf. condenser. When aligning the receiver on the Broadcast Band, connect the generator to the Antenna wire through a .0002 mf. condenser, and on the seven short wave bands through a 400 ohm carbon resistor.

In general it is not recommended to re-align the bandspread coils unless it is definitely necessary. If re-aligning is found to be necessary, take off the dial pan by removing the five screws, as indicated on the diagram.

First adjust the oscillator iron core to make the pointer correspond with the calibration mark. Then adjust the antenna iron core for maximum output. The signal generator must be accurate within 5 kc. on each band, and the use of a calibrating crystal oscillator is recommended. Otherwise a broadcast signal of known frequency may be used.

In this receiver the oscillator frequency is higher than the signal frequency on the broadcast band and lower on the seven other bands.

Below—plan view of the Pilot model 340 "short" and "broadcast" wave receiver, showing the location of the tubes and the adjustment screws for the different bands as seen from the front of the chassis.

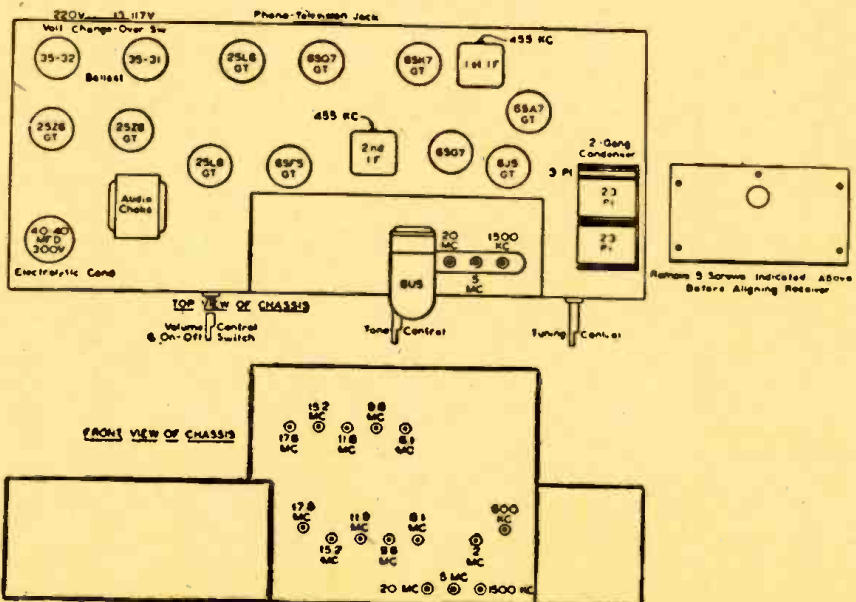

Radio Service Data Sheet

322

PILOT Model 340 Broadcast and Short-Wave Receiver 10 Tubes—110 Volts A.C. or D.C.

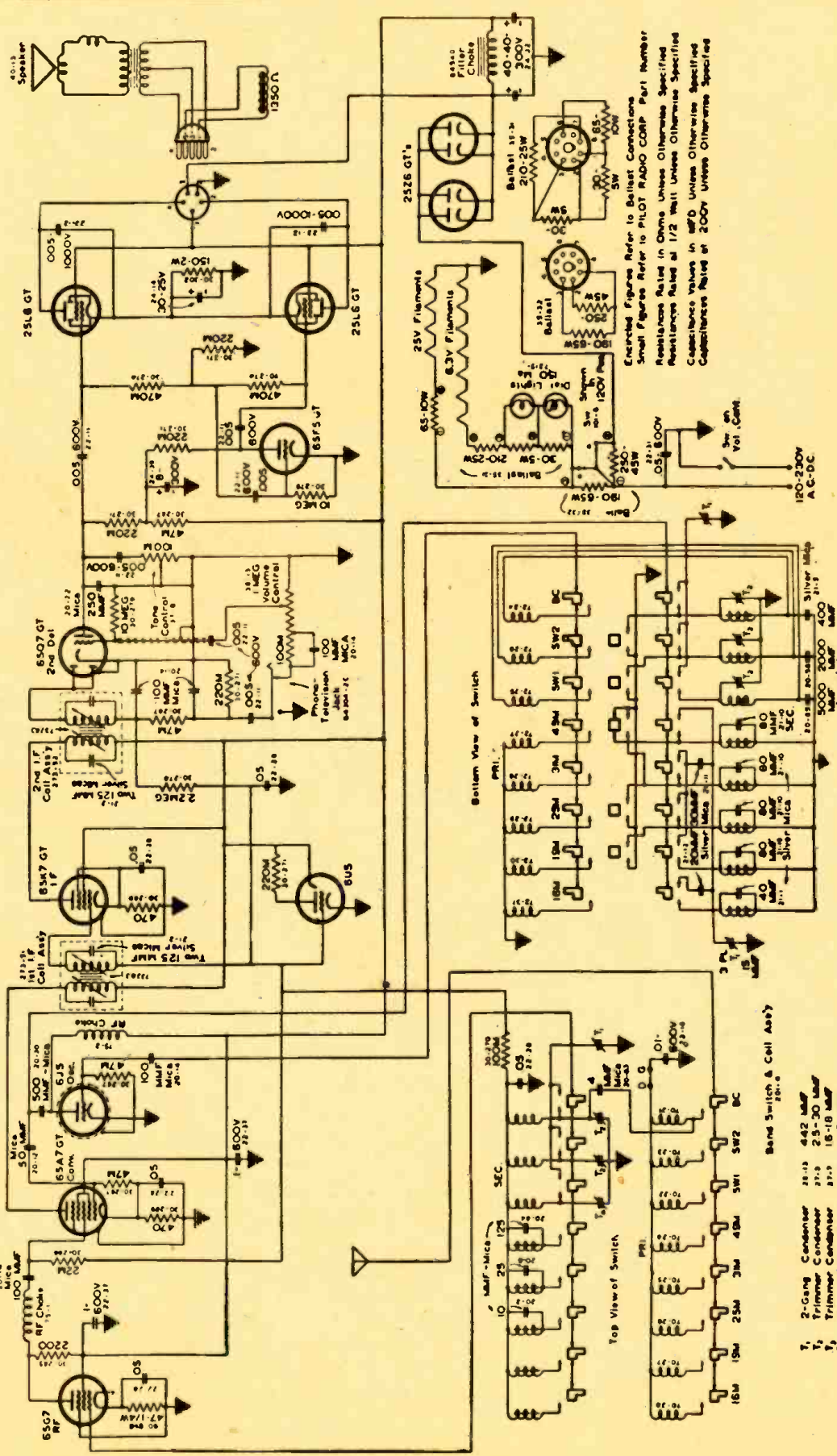

Excerpted Figures Refer to PILOT RADIO CORP. Part Number
Resistance Values in Ohms Unless Otherwise Specified
Resistance Rated at 1/2 Watt Unless Otherwise Specified
Capacitance Values in μ F Unless Otherwise Specified
Capacitance Rated at 200V Unless Otherwise Specified

The diagram above shows the arrangement of the ten tubes in the Pilot Model 340 series A.C.-D.C. receiver, which tunes in all of the important short-wave bands and the American broadcast band as well. The various coils for the different bands are switched into and out of circuit by means of the "master" control switch shown. The method of aligning the I.F. amplifier and the other circuits of the receiver, are carefully explained in the accompanying text.

- Band Switch & Cell Assy**
- T₁ 2-Gang Condenser 20-10
 - T₂ Trimmer Condenser 25-30 M μ F
 - T₃ Trimmer Condenser 18-18 M μ F
 - T₄ Trimmer Condenser 5-5 4-70 M μ F

A Complete P.A. System

At Very Low Cost

RICARDO MUNIZ, E.E.* and ROBERT J. BERGEMANN, JR.**

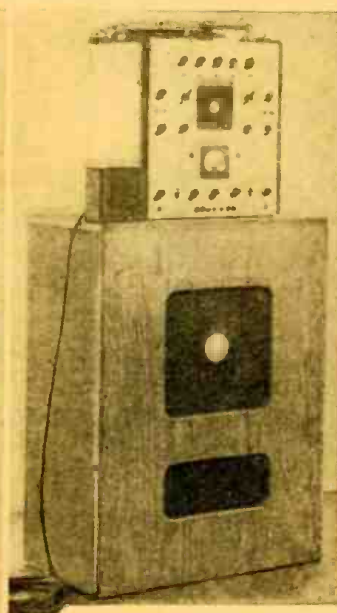
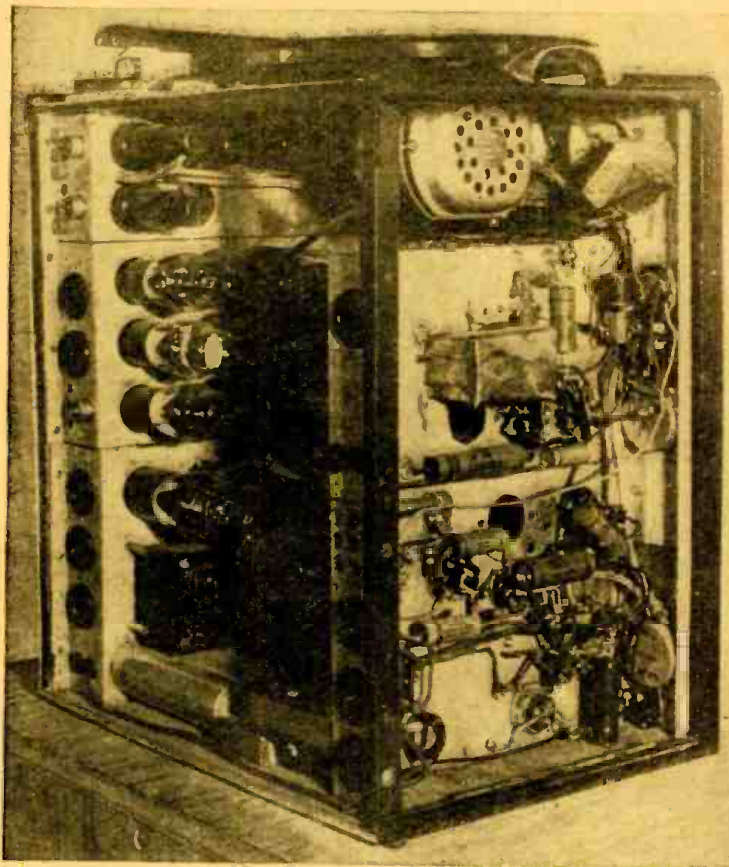

The portable P.A. system here described can be built from spare parts, where this is necessary; the circuit used is so flexible that practically every requirement can be met. The Serviceman as well as the Experimenter will find this universal P.A. system extremely valuable and he should file the data in his handbook.

Above—The complete portable P.A. system with the high-fidelity speaker mounted in the bass reflex cabinet.

Photo at left shows view of the main chassis array, with amplifiers and phono motor. The sectional unit construction makes repairs a simple matter.

HIGH fidelity, wide-range tone control, accessibility and portability are here made available to the home constructor at extremely low cost. In this modern Public Address System costly components have been kept at an absolute minimum. The circuit design together with the wide range electronic tone control give fidelity rivaling that found in Broadcast Station amplifiers.

For the constructor wishing a complete system which can be readily carried around from job to job without the need of hauling a multitude of cases and packages this unit is the ideal one. In spite of the great compactness it is found that the accessibility of components is greater than that in the more usual designs. The chassis are mounted in a vertical position on the two sides of the case and these two sides are removable. The sides of the cases are arranged as sliding panels which, when removed, expose the "innards" of each chassis. The tubes are easily reached for test or replacement when the back is removed.

The constructor will be pleased to know that drawings for the speaker cabinet will appear in the second part of the article in next issue. The plans given contain the details for the speaker cabinet which is of the bass reflex type, and also the main case, with its chassis and panels.

Since each chassis is a separate unit and

each panel is also a separate unit, they may be removed individually for changes, improvements, repairs, etc. This feature is a very important one. Experience has taught us that obsolescence is the bogeyman of the radio trade. Here is a unit that is as nearly obsolescence-proof as it is possible to come.

Heater type tubes have been used throughout so that the horizontal placement of the tubes will do no harm.

SPEAKER CABINET: This cabinet is adequately pictured in the sketches. It is designed so that the *black wave* reinforces the *front wave* of the speaker at the lower frequencies, thus improving the bass response. A Utah 12P speaker was found to give very satisfactory performance. The cabinet should be stained and should be given two coats of shellac and one of varnish, to preserve the wood and keep it from warping. It is made of 3 ply 3/4" fir and is lined with 1/2" celotex. The celotex covers practically all the inside. The details of the joinery will be shown.

"MIKE" CABINET: This cabinet was designed to house a small Utah 3P speaker and Thordarson T-14S83 transformer, used as a step up and impedance-matching transformer. A wide variation in the final appearance is possible with this unit, so as to suit the individual taste, provided one important principle is adhered to: *Do not close the back of the cabinet with a piece of wood.* Leave the back of the mike cabinet open. A grill cloth may be used on the back to make it look neat.

Another trick which will improve the

performance of the Utah 3P (used as a mike) is to insert a small piece of soft sponge rubber between the back of the cone and the back framework of the speaker unit. This will practically eliminate "cone resonance." This piece may be adjusted while listening to the output of the amplifier off a pair of phones—until quality sounds best. Having found the best position of the piece of rubber it will be found that the electronic control will enable you to make this homemade microphone sound like an expensive dynamic mike.

The unit herein described was built in large measure from parts found in old radios, the junkbox and "bargain counters." Since then these parts are being replaced by standard equivalents, these equivalents are given in the parts list, so that the results attained can be readily duplicated. The constructor may use "junk" temporarily as was done by the authors—and later replace a unit at a time with standard parts.

The *record-player* used by the authors was, as can be seen in the photographs, mounted on top of the "CASE." It consists of a crystal pick-up and a small self-starting motor having a ten-inch turntable.

Perhaps the most outstanding feature of this P.A. system next to the unique housing "CASE" is the electronic tone control. It will give a 15 db. boost or cut off either *bass* or *treble* or both at SEPARATE controls; there is little interaction between the controls. It will be noted that the *tone-control* circuit in the pre-amplifier chassis is very simple indeed. Many constructors will want to incorporate this simple electronic tone control in existing P.A. amplifiers. It works very well. You will note that a T-14C70 tone control choke is used in the cathode of the 6C5 for bass and a

* Engineer WNYE: Radio Instructor Brooklyn Technical H. S.

** Graduated June, 1940, from Brooklyn Technical H. S. Former President of the Radio Club at B.T.H.S.

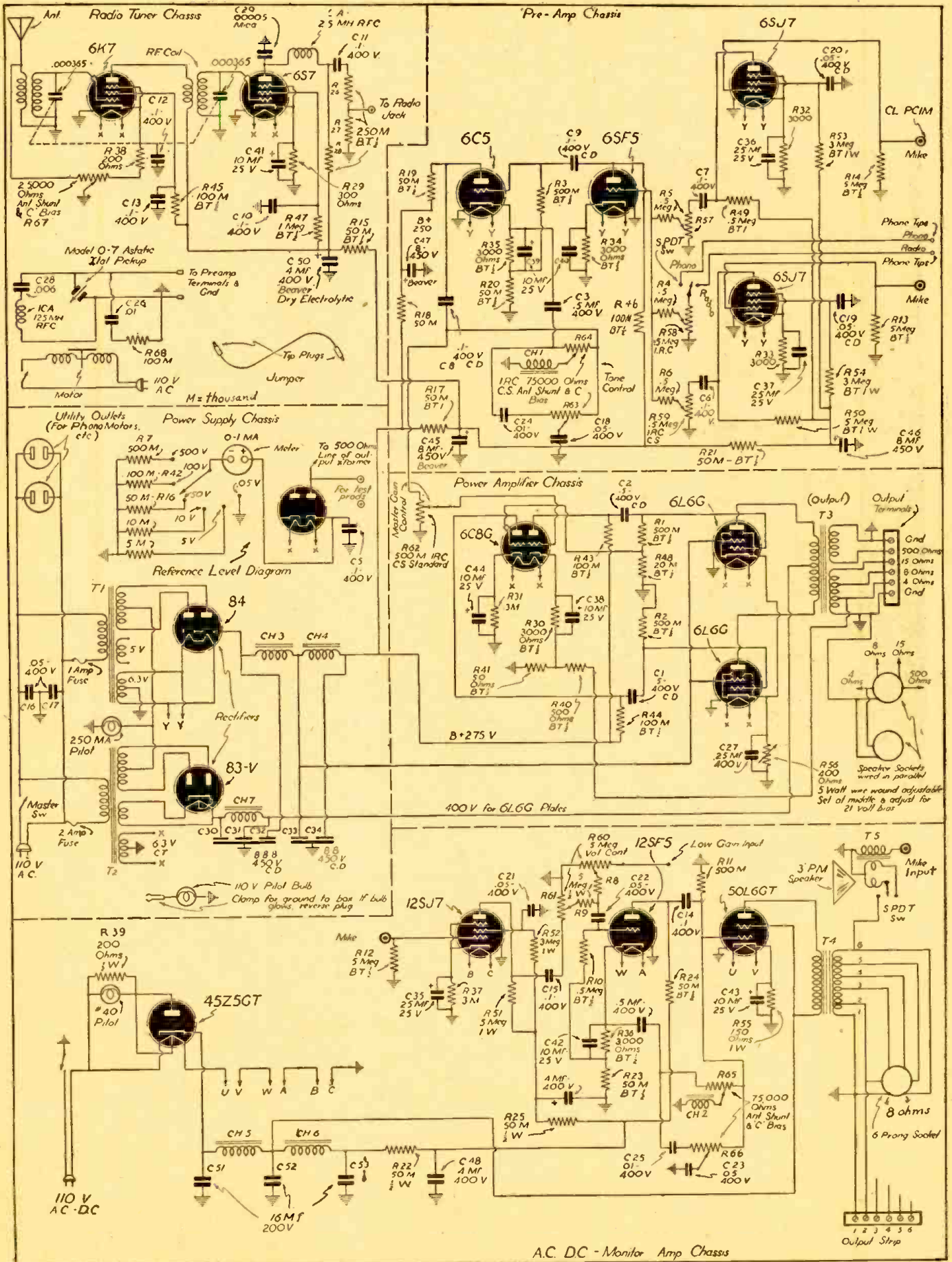

Diagrams above show the various microphone and phono pickup circuits, as well as the amplifier stages, etc., used in the complete portable P.A. system designed by Messrs. Muniz and Bergemann.

WEBSTER RECORDER AND PLAYBACK ASSEMBLY



Plays records up to 12" dia. Cuts records up to 10" dia. outside-in at 110 lines per inch, 78 RPM induction type motor employs an internal rim-drive to the turntable. Assembly includes 10" turntable, motor, cutting mechanism, crystal cutting head, 1/2 ounce low-pressure crystal pickup. Complete unit with case and Astatic microphone. Wt. 25 lbs. Size 16"x13"x9". For 110V. 60 cycles.

NOTE: Should you want to purchase the above units separately, your prices will be as follows:

Webster Recording Unit only	\$19.95
Case	4.95
Microphone	4.45
Cutting Transformer	.75

Positively no C.O.D. shipments made, unless order is accompanied by a deposit of at least 25%. All prices are accompanied by a deposit of at least 25%. All prices are F.O.B. Chicago.

ARROW RADIO CO.

Div. 542, 900 to 910 Jackson Blvd., Chicago, Illinois

TELEVISION ARTICLES

In Past Issues of Radio & Television

- New Portable Television Pickup—Sept., 1940.
- 10 by 8 Inch Television Images—Television Club, Brooklyn Tech. High School—Oct., 1940.
- Amateur Television Made Practical by New Image Pickup Tube—Aug., 1940.
- A Semi-Portable Television Receiver—R. H. Horn—Jan., 1941.
- Television Travels 190 Miles Over Wires—Mar., 1941.
- Interference Phenomena in Television Reception—Thornton Chew—April, 1941.

Did You See . . .

The list of Articles
on

"Frequency Modulation"
on page 541?

NEW "FM" STATION

The opening date for Westinghouse station W75P, new Frequency Modulation affiliate of KDKA, was April 4.

A two-hour broadcast, carried both by KDKA and W75P, heralded the debut of the new station. The show included a review of some of the new programs to be heard on the FM station, a parade of KDKA talent, several special event pickups and other special features.

CD .01-400 volt condenser is similarly used with a potentiometer in the cathode for "highs."

The radio-tuner is a simple TRF unit designed to bring in "hi-fi" reception of local Broadcasting stations. We anticipate putting in an FM chassis soon. The RF coils came out of junked radios—the ganged condenser did also.

A 0-1 ma. meter was used in the system. It was made available as a Volt-Ohm-Milliammeter by use of suitable multipliers and shunts, made of carbon resistors filed to accuracy. The meter is also used as a reference or DB meter by connecting it to the 500 ohm impedance winding of the output transformer, in series with the diode rectifier and specified resistors. Pin-jacks were used.

A monitor-amplifier is incorporated which has sufficient power to do a fair job of pinch-hitting for the big amplifier if the latter should go "blooey" during an engagement. It can be used also on jobs where you "suddenly" discover that only D.C. is available in the "Hall." It serves normally as a monitor bridging amplifier. Its input can be connected by phone tip "patch-cords" to the preamplifier output for this function. It puts out about 2.5 watts and has one mike and one phone channel.

The main power amplifier makes use of a 6C8 as an audio stage and as a phase inverter. A pair of 6L6's or 6L6-G's are used as a final stage. Inverse feed-back for improved fidelity at high output is obtained from the T-89S75 output transformer.

This unit has attracted wide attention wherever it has been used. It is really a "Magic Sound-box."

RESISTORS

- 11—1.R.C., type BT-1/2, 500,000 ohms, R-1 to R-11
- 3—1.R.C., type BT-1/2, 5.0 megohms, R-12, R-13, R-14
- 11—1.R.C., type BT-1/2, 50,000 ohms, R-15 to R-25
- 3—1.R.C., type BT-1/2, 250,000 ohms, R-26, R-27, R-28
- 9—1.R.C., type BT-1/2, 3,000 ohms, R-29 to R-37
- 2—1.R.C., type BT-1/2, 200 ohms, R-38, R-39
- 1—1.R.C., type BT-1/2, 500 ohms, R-40
- 1—1.R.C., type BT-1/2, 50 ohms, R-41
- 6—1.R.C., type BT-1/2, 100,000 ohms, R-42 to R-46, R-68
- 1—1.R.C., type BT-1/2, 1.0 megohms, R-47
- 1—1.R.C., type BT-1/2, 20,000 ohms, R-48
- 3—1.R.C., type BT-1, 0.5 megohms, R-49, R-50, R-51
- 3—1.R.C., type BT-1, 3.0 megohms, R-52, R-53, R-54
- 1—1.R.C., type BT-1, 150 ohms, R-55
- 1—1.R.C., type ABA, 400 ohms, 10 watt adjustable (set about midway) R-56
- 6—1.R.C., type 13-133 potentiometer, 0.5 megohms, R-57 to R-62
- 4—1.R.C., type 14-125 pot., 75,000 ohms, R-63 to R-66
- 1—1.R.C., type 14-120 pot., 25,000 ohms, R-67

TRANSFORMERS, CHOKES

- 2—Thordarson chokes, type 14C70, Ch-1, Ch-2
- 4—Thordarson chokes, type 13C28, Ch-3, to Ch-6
- 1—Thordarson choke, type 57C54, Ch-7
- 1—Thordarson trans., type 75R47, T-1
- 1—Thordarson trans., type 92R21, T-2
- 1—Thordarson trans., type 89S75, T-3
- 1—Thordarson trans., type 13S38, T-4
- 1—Thordarson trans., type 14S83, T-5

TUBES

- 1—Sylvania 12SJ7
- 1—Sylvania 12SF5
- 1—Sylvania 50L6GT
- 1—Sylvania 45Z5GT
- 1—National Union 83V
- 1—National Union 84
- 2—National Union 6L6G
- 1—National Union 6C8G
- 1—National Union 6C5
- 1—National Union 6SF5
- 3—National Union 6J7
- 1—National Union 6K7
- 1—National Union 6H6

MISCELLANEOUS

- 1—Astatic, model O-7 crystal pickup
- 1—General Industries, phono motor
- 1—Utah 12-P permanent magnet speaker
- 1—Utah 3-P speaker (to be used as dynamic mike)
- 1—Shure Bros.—708SH xtal mike (with suitable matching circuit)
- 13—Amphenol, type MIP octal sockets
- 1—Amphenol, type MIP, 5 prong socket
- 4—Amphenol, type MIP, 6 prong sockets
- 1—Amphenol, type MIP, 4 prong socket
- 2—Amphenol, type 61F A.C. receptical
- 3—Amphenol, type CL PC1M mike connectors
- 3—Amphenol, type PC1M connectors
- 6—Birnback, 280-25, 20 ga., hookup wire, assorted colors
- 1—Fifty foot, Birnback, type 573 zip cord (for speaker cable)
- 1—Fifty foot, Birnback, type 872 mike cable
- 1—I.C.A. type 6207 r.f. choke, 125 mh.
- 1—I.C.A. type 2277 r.f. choke, 2.5 mh.
- 2—I.C.A. type 2439 6 terminal mounting strip
- 6—I.C.A. type 889B insulated tip jacks
- 12—I.C.A. type 1125 bar knobs
- 3—I.C.A. type 1230 SPST toggle switches
- 3—I.C.A. type 1236 SPDT toggle switches
- 1—Jar I.C.A. No. 5008 6-32 machine screws
- 1—Jar I.C.A. No. 5071 6-32 nuts
- 1—Jar I.C.A. No. 5085 shakeproof washers
- 1—Meter 0-1 ma.

Parts List

CONDENSERS

- 4—Cornell-Dubilier, type DT-4P5, 0.5-mf., 400 V., C-1 to C-4
- 11—Cornell-Dubilier, type DT-4P1, 0.1-mf., 400 V., C-5 to C-15
- 8—Cornell-Dubilier, type DT-4S5, 0.05-mf., 400 V., C-16 to C-23
- 3—Cornell-Dubilier, type DT-4S1, 0.01-mf., 400 V., C-24, C-25, C-26
- 1—Cornell-Dubilier, type DT-4P25, 0.25-mf., 400 V., C-27
- 1—Cornell-Dubilier, type 1W-5D6, 0.006-mf., mica, C-28
- 1—Cornell-Dubilier, type 5W-5Q5, 0.00005-mf., mica, C-29
- 1—Cornell-Dubilier, type EA-8880, 8-8-8-mf., 450 V., C-30, C-31, C-32
- 1—Cornell-Dubilier, type EP-9808, 8-8 mf., 450 V., C-33, C-34
- 3—Cornell-Dubilier, type BR-252A, 25-mf., 25 V., C-35, C-36, C-37
- 7—Cornell-Dubilier, type BR-102A, 10-mf., 25 V., C-38 to C-44
- 3—Cornell-Dubilier, type BR-845, 8-mf., 450 V., C-45, C-46, C-47
- 3—Cornell-Dubilier, type BR-445, 4-mf., 450 V., C-48, C-49, C-50
- 3—Cornell-Dubilier, type BR-1625, 16-mf., 250 V., C-51, C-52, C-53

DIAL POSITION VS. POWER DEFINED

A campaign based upon its position on the dial is now being made by Station WMCA to educate listeners with the importance of dial position as against power. Defining wattage in terms of coverage, engineering data and Federal Communications Commission standards are used to support the campaign.

According to its figures, WMCA with 5,000 watts of power at 570 kilocycles on the dial can match the performance of theoretical 100,000 to 480,000 watt stations at higher frequencies. This is due to the progressive loss of power through ground absorption of signal strength among stations higher up on the dial.

The table of comparisons in dial position vs. power, based on curves prepared by the

Federal Communications Commission, is listed below. These figures are for a non-directional antenna. Since WMCA uses a directional antenna system, its power is actually three times as great in centers of population.

Dial Position Frequency	Watts Needed to Deliver *2 Millivolt Signal 43 Miles From the Transmitter
570 Kc. (WMCA)	5,000
1000 Kc.	76,000
1200 Kc.	158,000
1600 Kc.	480,000

*Unit of signal intensity defined by F.C.C. as good coverage for city residential sections.

Operating Notes

DELCO SET

This particular set would play along fine for several minutes when first turned on, then would gradually break in to a most nerve-wracking combination of a howl and whistle. Usually the volume would increase just before the howling would start. Bypass condensers were suspected, but unable to lay the blame to any certain one, the entire lot of "tubulars" were replaced. On the bench the set played for several hours with no trouble, so it was reinstalled in the car. A few days later the customer was back with the same complaint! A new set of tubes was tried but this did not remedy the trouble. Finally, in desperation, a new filter block was installed, although the old one tested perfect. This did the trick. Later, an examination of the old block showed that the heat generated within the condenser can after a few minutes' use, was sufficient to cause the 12-mf. 25-volt condenser to become intermittent, although it tested "OK" on the capacity bridge. The part number of the original block is 1209285.—Lionel Haid, Acme Radio Service, Richmond, Ind.

ZENITH 5G510

In four cases the sets were completely inoperative and had no "B" voltage. After replacing the switch and volume control they worked perfectly. I learned that these switches can be obtained separately, which permits a faster job at less expense.

In regard to the same model set, I have had three cases where the output transformer has been found defective. These transformers have to be obtained by their own part number, also model number of set, as there are some of these sets out with one type output transformer and others with a different type.—John Sweeney, Sweeney Radio & Music Co., Falfurrias, Texas.

EMERSON D-139

Owners of the Emerson Model D-139 complain of noise a few months after purchase. This is caused by a capacitor that is too near the bleeder, the heat from which causes melting. By replacing this capacitor the noisy condition can be remedied according to Nat Laster in *Service Tips*, RCA Radio Service News.

RCA 1939 MOTOR TUNED SETS

In areas where the prevailing line voltage varies from 120 to 128 volts A. C., "jittering" of the dial before centering on the desired station may be experienced with the RCA 1939 motor tuned sets. This sometimes occurs in spite of the most careful observance of the instructions in the service notes.

I find that all such troubles cease with the installation of a 25 watt dropping resistor in the A. C. line, of sufficient resistance (5 to 15 ohms) to limit the motor voltage to the required 24 volts. Care should be taken not to get the tube filament voltages below the rated 6.3 according to H. B. Hodges in *Service Tips*, RCA Radio Service News.

CHEVROLET 1939 AUTO SETS

Excessive vibrator hash in the speakers of 1939 Chevrolet Auto sets can be overcome to a great extent by removing the mounting nuts on the push-pull input transformer and revolving it to cancel the hash. Remount the transformer with freshly drilled holes. Needless to say, failure to punch out fireboard holes behind the speaker leads to dangerous over-heating as well as seriously sacrificed audio frequency response according to Merl Saxon in *Service Tips*, RCA Radio Service News.

Using Theater Sound Systems for "Hearing Aids"

G. R. LaPOINT

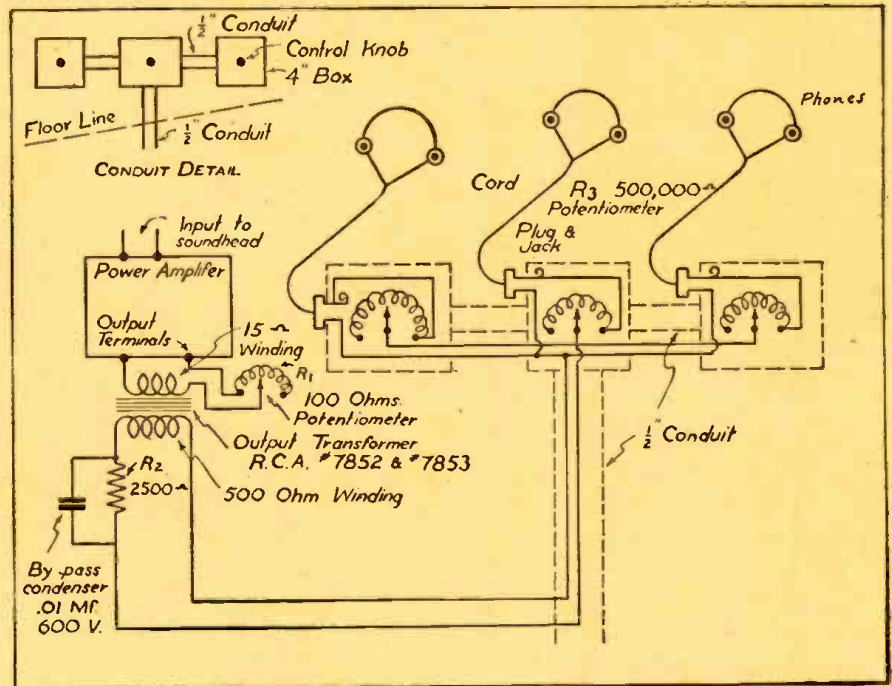

The diagram above shows how the author connected a number of output terminals for "hearing-aids" in a theater. With the system shown it is possible to regulate the strength of the sound heard in the various headphones.

FOR the past four years the writer has been using this hookup with great success in the Strand Theater at Westboro, Mass. It has given no trouble and people come from miles around to use this outfit. You can actually hear them breathe with it.

We use only three seats for this purpose, on the side wall halfway down the auditorium.

Earphone boxes are 4 inches square, commonly used for electrical wiring. The jacks are of the midget type, mounted in a knock-out hole on the side of the box and insulated within thin pieces of masonite. The same material is used for the cover, which screws on in place of the metal cover that comes with the box.

The entire assembly for the earphone stations is made up of 1/2-inch conduit in the form of a "T." The conduit is fastened onto the boxes with locknuts and bushings. The wire from the transformer to the earphone stations can be S. J. rubber-covered cord or BX. The wire inside of the conduit assembly can be No. 18 cord or No. 14 rubber-covered 600 volt wire.

The earphones are kept in the boxoffice when not in use. The patrons of the theater ask for them as they enter.

The shaft of the individual volume controls is mounted on the masonite cover of each box, projecting through a hole in the cover.

The RCA universal output transformer No. 7852 is mounted in a large metal box, with a bakelite cover through which the shaft of the 100 ohm over-all volume control projects. The wiring from the transformer box to the power amplifier should be of armored cable BX. The 2,500 ohm resistor is mounted in the same box with a .01 mf by-pass condenser shunting the resistor. It should be carefully wrapped with friction tape.

The secondary or 15 ohm side of the transformer connects to the 15 ohm output

of the power amplifier, with the 100 ohm potentiometer in series with these windings to prevent unbalancing, excessive drain, or disturbance to the speaker line. This unit also acts as an over-all or master volume control and should be adjusted to give the lowest possible volume, consistent with good volume at headsets, or just below the point where the earphone will not rattle at the average house setting of the sound amplifier volume control. This adjustment should be made with R-3 turned on full at each station.

R-2 is a limiting resistor designed to prevent short-circuits or damaged earphone cords from interfering with the speaker line. The bypass condenser across this 2500 ohm resistor tends to ease the A.C. currents past this point.

R-3 is an individual volume control at each earphone station, whereby each *hard-of-hearing* patron may regulate the volume to his own requirements. This potentiometer has a resistance of 500,000 ohms, with or without tapered resistance wire or unit.

Earphones can be of any value between 1,500 and 3,000 ohms, with headband attached. Practically any secondary resistance can be used on the output coupling transformer from 500 to 4,000 ohms. It is not necessary to have exact impedance matching on the earphone side of this transformer. However, the impedance must be exact on the 15 ohm side, or whatever your amplifier output impedance may be. The RCA transformer is a universal type and will match any standard amplifier output line.

More earphones can be used if the earphone side of the transformer is adjusted to 500 ohms. Each pair of earphones consuming about 50 milliwatts, you should be able to attach 8 or more pairs of earphones to this line, with a drain on the amplifier of about 1/2 watt; this certainly will not put it out of commission.

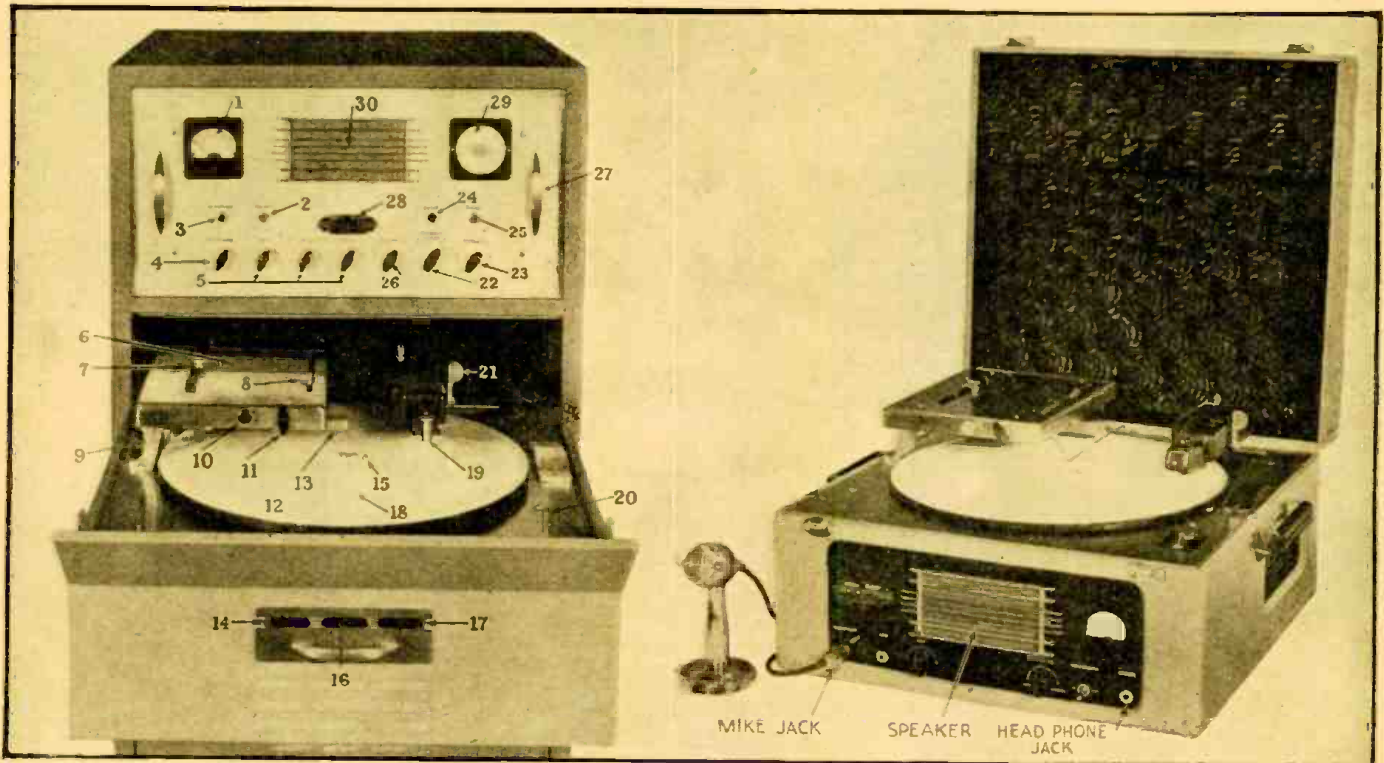

Two different models of the Sound Recorder; the voice is recorded on unbreakable paper discs.

PAPER-DISC SOUND RECORDER

The Memovox is a newly developed "sound-recording" apparatus suitable for use in office or board room, etc. Long recordings may be made on paper discs at slight cost. These discs may be played back as many times as required, and they may also be mailed for transcription by the recipient.

THE accompanying photos and diagrams show one of the latest developments in sound recording for use in offices, board meetings, etc., and known as the

Memovox. Through a microphone (placed in any convenient location in a room) the apparatus records voice or music. The recordings are made on a durable light plastic disc, ideal for air mailing or compact filing. Each side of the disc records one full hour without interruption (or may be stopped and started at will). When one hour of recording on the disc is completed, the disc is simply turned over and recording begins on the *reverse* side. The cost of one hour of recording is only a fractional part of a dollar. There is absolutely no processing—*one can record and reproduce simultaneously!* By utilizing a setback mechanism, one can play-back what was being recorded several minutes earlier, while the device is still continuously recording—or one may listen to the full hour when the recording has been completed.

For transcribing purposes the operator using the system can employ either ear-phones or loudspeaker, whichever she wishes. The transcriber presses the *run* foot pedal, listens to as many words as she thinks she can retain and then lifts her foot. As soon as the foot is lifted and the contact broken, the turntable becomes stationary at the point of the last word she heard. When she presses the *run* pedal again, she immediately picks up the next word. If the transcriber desires to set back and repeat what she heard or typed, she places her foot on the *setback* pedal. The turntable then runs in the reverse

direction until it has traversed the necessary distance to find a specific part. To proceed, as before, she merely presses the *run* pedal.

Whether the recorded voice discs are to be reproduced in group meetings, in homes, or private offices, this instrument is as simple to operate as any radio set. The volume can be turned up or down without loss of any clear tone reception.

It is not necessary to run through the entire record to find a specific part. The operator simply sets the *reproducer* head to the point where the subject is indicated on the *log card*, and will repeat only that portion of the record desired. Through the simple pedal mechanism, in operation any part of the disc may be repeated as many times as necessary.

Over 120 hours of continuous recording may be stored in one inch of filing space. Either side of every disc is capable of recording over a full hour's material, and 60 of these discs may be stored away comfortably in a single inch of filing space. The discs are tough, flexible, and almost indestructible under any reasonable usage, the manufacturers claim. There are no threads or shavings with this machine. The discs used to record the speech are non-inflammable and safe to handle. The discs will not break if they are dropped and may be mailed anywhere. The discs may be played back at any time and also through many reproductions, with no appreciable change in the high fidelity reproduction. The discs are impervious to ordinary changes in temperature and humidity and are not affected by weather.

The photographs show large and small models of the special recording apparatus here described and the loud speaker is built into the apparatus. A headphone jack is provided with a foot control pedal and also a microphone jack. A feature of this apparatus is that it is not necessary to talk close to the microphone. It may be placed in any convenient location in the room.

The automatic repeat mechanism makes it simple for any stenographer to transcribe the recorded voice with ease.

FUNCTIONAL CHART OF MODEL AA CONTINUOUS RECORDER

1. Recording Level Indicator: Shows the recording level amplitude in arbitrary markings on an easy-to-read minimum and maximum scale.
2. Master Switch: This switch controls the power supply to the entire instrument.
3. Microphone Jack: Permits the connection of a high impedance microphone to the recording system.
4. Microphone Gain Control: Regulates the sound level from either a local microphone or a high impedance input.
5. Input Channel Gain Controls: These are mixers from three 20,000-ohm bridging circuits, which allow any one of three signals of different intensities to be equalized and recorded.
6. Log Card: This card is inserted on the log card deck, and indicates the elapsed recording time. Space is provided on the card for notations by the operator. Card is then filed with the record and remains available for accurate reference when needed.
7. Log Card Clamp: Holds the log card in place.
8. Log Indicator: Follows along the log card as the recording head moves across the record, and is used in indexing the record.
9. Carriage Safety Stop: Used to lock the recorder head into a fixed position when machine

- 10. Playback Lift Knob: A turn of this knob lifts or lowers the playback head away from or onto the record.
- 11. Playback Lag Adjustment: This adjustment makes it possible to reproduce material just recorded upon the disc while further recording upon the same disc is simultaneously under way.
- 12. Memodisc Record: A thin record whose capacity (using both sides) exceeds two hours.
- 13. Playback Head: A sensitive reproducer, utilizing a genuine sapphire needle.
- 14. Motor On: A green pilot light indicating when the recorder motor is on.
- 15. Record Drive Pin: Holds the disc firmly in place while recording is under way.
- 16. Motor Warning: An amber pilot light which flashes on when there are only a few minutes of recording time left on the disc.
- 17. Motor Off: This red pilot light goes on when the recording arm, upon reaching the outside edge of the disc, has automatically stopped the motor.
- 18. Turntable: A 16½-inch round table which carries the disc. The turntable is driven by a

- rubber-tired drive wheel on the under side.
- 19. Recording Head: A substantial, crystal cutter, utilizing a sapphire embossing stylus.
- 20. Manual Switch: Permits the recording unit to be started at any desired time. Independently of the automatic starting provided by the clock.
- 21. Recording Head Control Lever: Throwing this lever forward lowers the recording head and engages the turntable, thus allowing apparatus to record. Throwing the lever backward engages the turntable, but does not lower the recording head, thus making it possible to reproduce without recording. When the lever is placed in a neutral position, the recording head can be moved to any desired position on the disc for either recording or playback.
- 22. Reproducer Control: A switch which allows the speaker to be connected to either of the reproducers, or into a monitoring position.
- 23. Compression Control: Introduces into the amplifier circuit a desired amount of compression up to the maximum. It tends to compensate for lower level signals and brings them up to the quality and loudness of the higher level signal. The compression operates within one milli-

- second, with no noticeable frequency discrimination or distortion.
- 24. Motor Switch: Controls the power to the turntable motors and clock, and allows the operator to stop and start the disc at will.
- 25. Headphone Jack: Plugging in this jack disconnects the speaker and allows the listener to hear either the material being recorded, or the reproduction of recorded material, through headphones.
- 26. Volume Control: Adjusts volume of either reproducer; also adjusts monitoring volume.
- 27. Control Panel: A satin-chrome front panel, mounted to the amplifier chassis.
- 28. Master Pilot Light: When on, this light indicates that apparatus is properly connected and ready to record or reproduce.
- 29. Timing Device: Used to start the recorders in sequence. This device is calibrated in time units to indicate the position of the recorder arm. At the end of each hour of recording, the timing device automatically starts the next turntable.
- 30. Speaker: A heavy-duty, wide-range loud speaker.

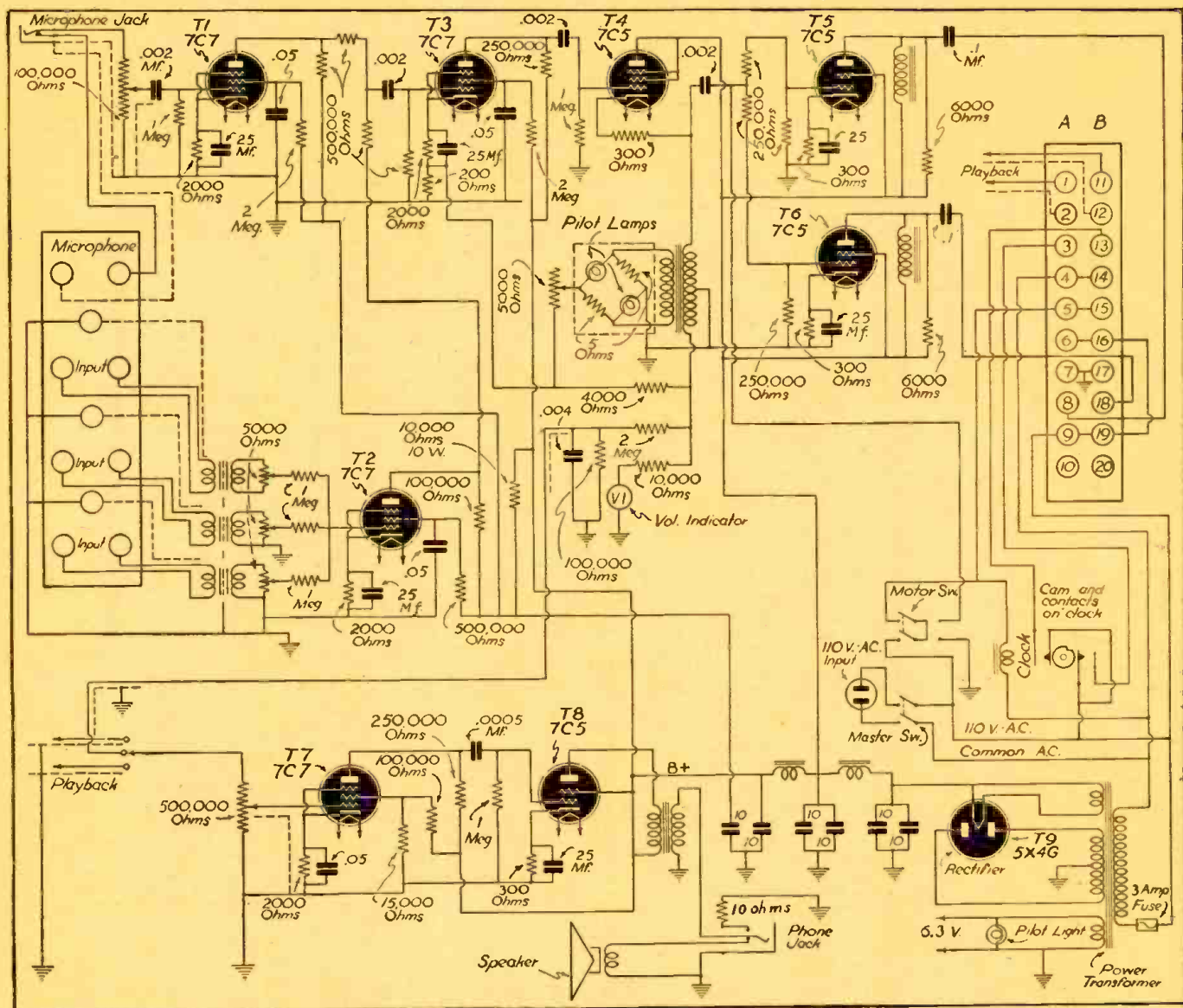

Wiring diagram of a typical Memovox Sound Recording Apparatus.

A METAL TAPE THAT TALKS BACK

RADIO announcers, actors and others are now taking "backtalk" from a strip of metal tape—and liking it. It seems that backtalk is the specialty of the Mirrophone. This is the way it works. Actor speaks into microphone. Actor's voice is recorded magnetically on a strip of metal tape. Actor flips switch and his voice comes back at him. Actor notes defects in pronunciation, emphasis, etc., and corrects them. That's

the theory anyway, a theory brought to practicality by Bell Telephone Laboratories. The mirrophone already has a number of diverse applications to its credit. One mid-western radio station, for instance, has a mirrophone set up in its announcers' room. As each announcer comes on duty, he reads his commercial copy to the mirrophone, then listens to the "playback." Station's executives say that the announcers, able to

hear and criticize their own speech without the delay attendant on processing "wax" recording, have greatly improved their work. Immigrants who want to be "real Americans," have found the mirrophone helpful in eradicating accents. Many universities and schools have put the mirrophone to work in their speech departments. The device has also been found helpful to stutterers and other speech defectives.

Build YOUR OWN Experimental ELECTRONIC ORGAN

W. K. ALLAN

THE electron tube type of organ is a true electronic organ because the only moving parts are electrons (except the keys and speaker diaphragm). Consequently its construction requires electrical rather than mechanical skill, which makes it particularly suited to electrical experimenters, radio men, and sound specialists.

APPLICATIONS

Captain Richard H. Ranger went early and far in this field having built *Rangertone*

The editors have received many inquiries from readers asking for more data on the building of an electronic organ. They have finally prevailed on Mr. Allan to write an article on the subject. The second part will appear in the next issue.

organs as large as three manuals with over four hundred tubes using twelve-channel amplifying systems, each complete to speak-

er. His organs feature many useful innovations such as; making the melody or root note play louder, adding inharmonic frequencies to the note (i.e., not integrally related to the fundamental), complete envelope control, synthesizing control, thirty-two foot bass, and the use of tuning forks for frequency stability.

In Europe, electronic organs producing tones by heterodyning radio frequencies have been built. As Meissner points out a five octave 61 note audio oscillator organ,

The diagrams below are explained in the text—we are sure our readers will find this electronic organ series a very interesting one.

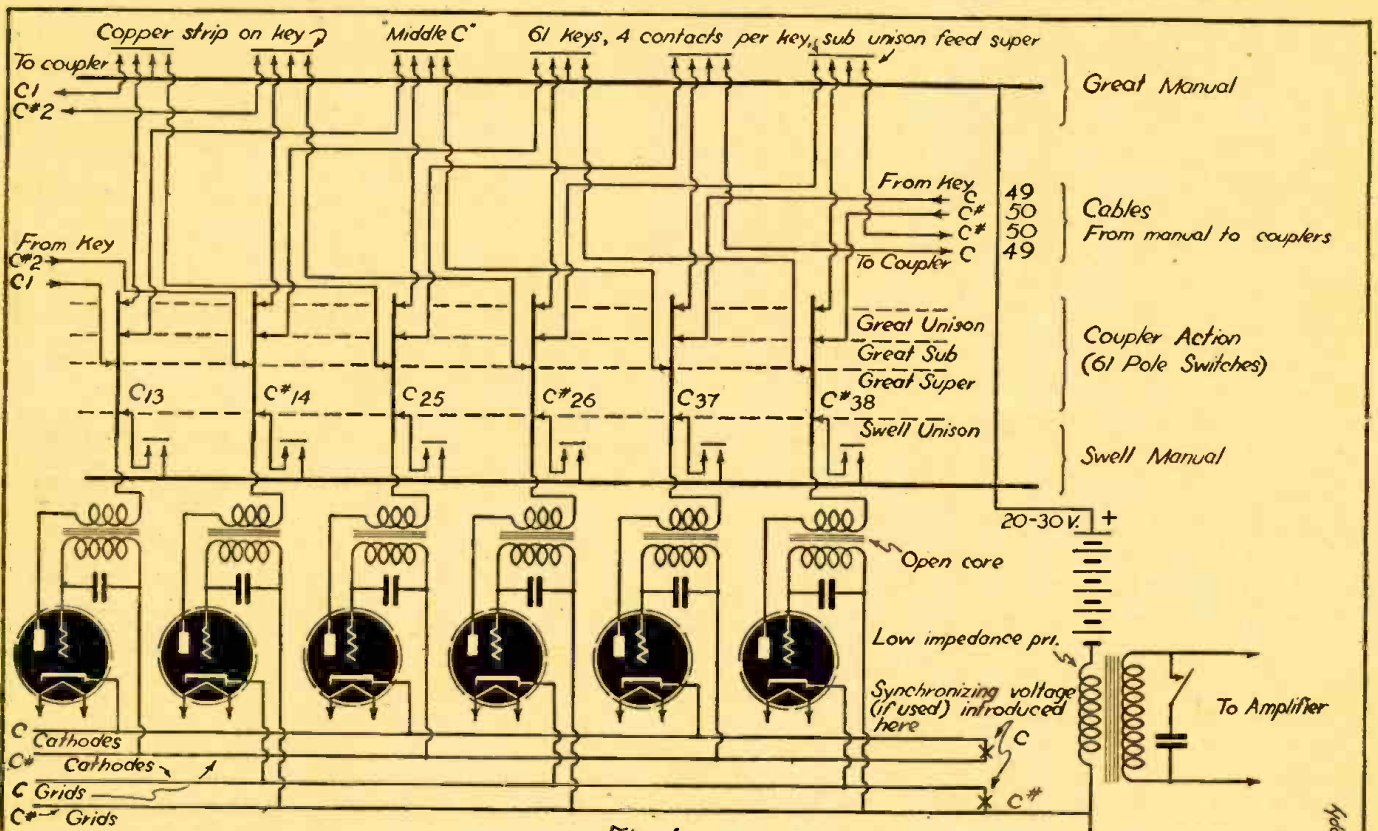
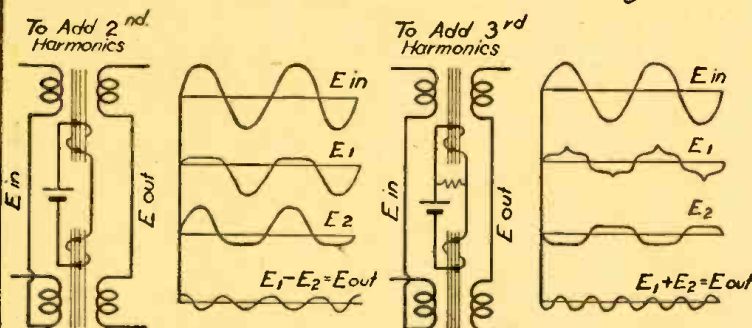

Fig. 1



Primaries add, secondaries oppose, cores saturated equally, opposite.

Primaries oppose, secondaries add, cores saturated unequally, opposite.

Fig. 2

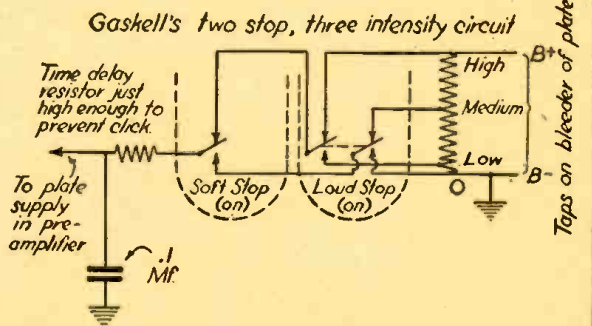

Soft off and Loud off	Output is 0
" on " " off	" " Low
" off " " on	" " Medium
" on " " on	" " High

Fig. 3

with 10 stops, requires 610 audio filters. But the same organ using the heterodyne method, requires beside the 61 Radio Frequency oscillators only 10 fixed frequency oscillators, each equipped with one filter to cut out certain of its harmonics, which will then be unable to beat with their corresponding harmonics in the 61 R.F. oscillators. Thus a single filter will affect the whole 61 notes; in this way a saving of 61 times in the number of filters required is effected, but the great drawback is frequency instability. One French organ, used for broadcasting, fed R.F. into the modulator using the radio station's carrier as the beat oscillator!

Organs using *neon tube relaxation oscillators* have been built by N. Langer and others. Their great advantages are the absence of tube filaments, and the fact that a relaxation oscillator is rich in harmonics.

The *Novachord* and *Solovox* are the most successful commercial electron tube organs.

The more one works with electric organs the stronger the conviction becomes that the ideal organ should use moving electrons instead of motion of gross matter.

BIBLIOGRAPHY

For the Rangertone organ obtain U.S. patents R. H. Ranger 1,901,985 (8,37); 1,901,986 (17); and 2,035,836 (3,8). Send inventor's name, patent number, and 10c for each patent to Commissioner of Patents, Washington, D.C. Do not send the bracketed numbers which are the sheets of diagrams and pages of description respectively. Or consult the files of a reference library. For information on Neon oscillator types see N. Langer 1,832,402 (2,4); 1,937,389 (3,4); 1,993,890 (4,7); 2,017,542 (3,8); and 2,035,238 (3,5). For the Novachord, see L. Hammond 2,126,464 (16,2); 2,126,682 (4,10); and T. J. George 2,203,432 (1,3); also Nov. '39 ELECTRONICS, and the Hammond service manual. For the Solovox see Nov. '40 RADIO-CRAFT, *Coupleux Givélet* has patents 1,905,996 (4,5); 1,911,309 (4,4); 1,980,911 (3,5) (key-click elimination) and 1,980,912 (2,3) (neon). Lee de Forest's pioneer electronic organ patent, filed April 24, 1915, is 1,543,990 (1,2).

TWO-MANUAL AUDIO-OSCILLATOR ORGAN

Fig. 1 is the wiring diagram of a two-manual organ. Fig. 10 March '40 Radio-Craft shows a photograph of the instrument.

Tubes—61 type '76 tubes are used because they were inexpensive (first used discarded '27s). Type 6W7G might be used if you ever intend to try the Novachord circuit. Heaters are operated considerably below 6.3 volts in order to prolong tube life and to reduce power consumption.

Plate Supply—The minimum voltage to produce oscillation, about 20 to 30 V. is used. This is easy on the tubes and eliminates the need for grid bias, but most important it reduces keyclick, causing the oscillations to build up gradually and thus producing a natural pipe organ attack. In systems where the tubes oscillate continuously this great advantage is lost, unless (as in the Novachord) tubes are used for keying, or as in the Robb Wave Organ, where variable resistance keying is used. (Relays with special contact pads, whose resistance varies from a megohm to less than 50 ohms, as the pressure of the closing armature is applied.) The plate supply must have low internal resistance and its voltage must not vary with the load, so that a heavy duty B battery is the simplest source. The plate supply is fed through the coupler system and manual contacts, so these leads must be kept very short, especially for treble

New SELF-BALANCING
DRIFT-CORRECTING
DIRECT-COUPLED AMPLIFIERS
FOR DISCRIMINATING MUSIC LOVERS
Designed by A. C. Shancy



These new amplifiers bridge the gap between the laboratory and the home, and made available for the first time, extraordinary equipment at less than ordinary prices. Built in a new way, without interstage coupling condensers or transformers. Although specifically designed to meet the strictest requirements of professional sound engineers, these direct-coupled amplifiers embody all desirable features sought by the most discriminating music lovers. Send for Literature.

AMPLIFIER CO. of AMERICA
17 W. 20TH STREET, NEW YORK, N. Y.

Articles
on
Frequency Modulation
In Past Issues
of This Magazine

- A Frequency Modulation "Converter"—R. Muniz, E.E., and J. Haddad—June, 1940.
- Frequency Modulation—R. Muniz, E.E., and J. Haddad—July, 1940.
- Hints on Operating the "FM" Receiver—R. Muniz, E.E., W. Oestreicher—Aug., 1940.
- Principles of Frequency Modulation—R. Muniz, E.E.—Aug., 1940.
- Principles of Frequency Modulation—R. Muniz, E.E., Part 2—Sept., 1940.
- Building the Browning "Frequency Modulation"—G. H. Browning—Oct., 1940.
- Frequency Modulation "Tuner"—to Suit Your Pocketbook—Larry LeKashman and Anton Schmidt—Oct., 1940.
- A Frequency Modulation Tuner—Herman Yellin—Dec., 1940.
- A "Pull-Swing" Frequency Modulation System for the Amateur—R. Muniz, E.E., Donald and Warren Oestreicher—Feb., 1941. (Also March, April and May, 1941.)
- Principles of Frequency Modulation—F. L. Sprayberry—Feb., 1941.
- An U.H.F. Receiver for FM and AM—S. Gordon Taylor—Feb., 1941.
- FM Receiver for the Home—L. M. Dezzettel—March, 1941.
- Principles of Frequency Modulation—Part 2—F. L. Sprayberry—March, 1941.
- Principles of Frequency Modulation—Part 3—F. L. Sprayberry—April, 1941.

YESTERDAY
TODAY
TOMORROW

SUPREME

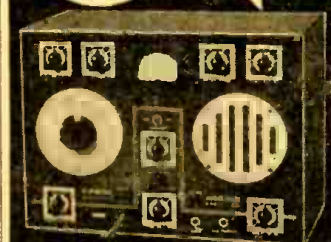

Every instrument scientifically engineered and soundly built for dependable, accurate, profitable radio servicing. See your jobber or write for new catalog.

SUPREME INSTRUMENTS CORP. GREENWOOD, MISSISSIPPI

NEW CATALOG
OF SOUND AMPLIFYING SYSTEMS
AUDIOGRAPH Sound Systems represent the latest in Public Address equipment—a complete line plus pre-tested accessories.

NEW LOWER PRICES
Outstanding quality and performance at prices that help you meet any competition.

WRITE FOR YOUR FREE COPY

AUDIOGRAPH
THE FIRST NAME IN SOUND
John Mack Industries—1313 W. Randolph Street, Chicago, U. S. A.

Amazing New "WALSCO"
STAPLE DRIVER



for radio men, electricians, or anyone doing stapling. Makes wire and cable installations twice as easy—much neater—saves half the time. Wires can be stapled in corners, behind pipes, into moldings—places never accessible with a hammer and ordinary staples. Drives staples even into walls, brick, mortar, etc. Magazine works automatically and holds strips of staples which come in several colors. Ask your jobber for demonstration and catalogue 41-C of all WALSCO PRODUCTS

or write **WALTER L. SCHOTT CO.**
5264 W. Pico Boulevard, Los Angeles, California

New Handy **UNIVERSAL REPLACEMENT**
Capacitors



Write for Catalog

SOLAR MFG. CORP., Bayonne, N. J.

New Direct-Coupled FM - AM

AMPLIFIER MANUAL

By A. C. SHANEY

Chief Engineer, Amplifier Co. of America



**For the Layman, Serviceman
Recordist and Engineer**

Regardless of whether you are interested in the finest type of phonograph reproduction, high fidelity recording, sound-on-film applications, FM or AM programs, you will find invaluable information in this practical handbook. Written by the leading exponent of direct-coupled amplifiers who has spent more than 10 years improving and perfecting the famous Loftin-White circuit.

Explains the theory and practical application of:

- Variable Speed Non-Overloading Push-Pull Expansion
- Non-Frequency Discriminating Scratch Suppression
- Push-Pull Balanced Direct-Coupled Amplification
- Push-Pull High-Frequency Equalization
- Push-Pull Low-Frequency Equalization
- Push-Pull Volume Compression
- Automatic Volume Limitation
- Automatic Volume Control
- Calibrated V.U. Indicator
- Audio Spectrum Control
- Remote Control

If you are interested in the latest audio developments, you can't afford to be without this complete compilation of authentic articles on Direct-Coupled Amplifiers. 32 pages 8 1/2" x 11". Over 100 diagrams and illustrations.

Priced to Cover Cost of
Printing and Mailing **20c**

Send Stamps or Coin

AMPLIFIER CO. of AMERICA

17 WEST 20TH STREET.

NEW YORK, N. Y.



University

HIGH EFFICIENCY results in **Sound National Defense** that is why **NATIONAL DEFENSE SOUND SYSTEMS** are equipped with **University Reflex HIGH POWER LOUSPEAKERS** **UNIVERSITY LABS.** 198 CHRISTIE ST. N.Y.C.

**Inventions Wanted
Patented or Unpatented**

We have been successfully selling inventions, patented and unpatented, since 1924. Write us, if you have a practical, useful idea for sale.

**CHARTERED INSTITUTE
of AMERICAN INVENTORS**

Dept. 109 Barrister Building, Washington, D.C.

PATENTS—TRADE MARKS

Booklet concerning Inventions & Patents Form "Evidence of Conception" with instructions for use and "Schedule of Government and Attorneys Fees"—Free

LANCASTER, ALLWINE & ROMMEL
Registered Patent Attorneys

436 Bowen Bldg.

Washington, D. C.

**USED
Correspondence
Courses**

COMPLETE HOME-STUDY COURSES and educational books, slightly used. Sold, rented, exchanged. All subjects. Money-back guarantee. Cash paid for used courses. Full details and illustrated 76-page bulletin catalog FREE. Write today!

NELSON COMPANY, 500 Sherman, Dept. E-210, Chicago

notes, in order that changes in length in the plate circuit e.g., via sub or super coupler, will not affect oscillator pitch. For this reason a Wick's Action or Casavant Roller Action manual in which the couplers are part of the keyboard would be much superior to the cable type. Used manuals may often be obtained from organ builders advertising in organ magazines. (A sample copy of *The Diapason* is 15c from "The Diapason," 1511 Kimball Building, 306 South Wabash Ave., Chicago, Ill.)

Coils—For the lowest octaves audio transformers are used, with various fractions of the laminations omitted, and the remainder restacked to leave a large air gap, because open cores show less variation in frequency with changing tubes and battery, since the plate current can't saturate the core. The coils are grouped so that magnetic leakage will occur between all C's, all C#'s, etc., to aid in keeping the octaves perfectly in tune. All the tubes of one note (e.g., C's) are placed next to those a fifth away, e.g. G's, all G's near D's, etc. This, because a fifth is the greatest harmony after an octave. The capacity on the bottom C1 is .15 mf. and on the top C61 about .0005 mf. Dual-winding telephone line-switch coils were used for the higher octaves but doubtless audio transformers would do. Interchanging coils, tubes, and condensers will come very close to the note; if you cannot get it, .001 mf. condensers serve as trimmers around C25 and compression type mica trimmer condensers can be used on the top octave. It is essential that the primary of the output transformer have a very low impedance, and its core an air gap, to prevent change in pitch when additional notes are played. An extra heavy audio transformer with a one square inch core and approximately 150 turns of #24 in place of the primary is used. A car ignition coil will work. If the primary has appreciable impedance compared to the oscillator's output, the signal output will drop as more notes are played, due to the shunting action of oscillators.

TUNING

The oscillators are tuned by (1) varying the number of laminations, (2) sliding a lamination in or out, (3) moving coil along the core, which is the central piece of the "E", (4) varying the air gap, (5) varying the capacity (trimmer condensers are used on the top octaves). Changing the plate voltage will upset the tuning, so determine it before starting to tune. Keeping the cathode leads and grid returns of all C's, all C#'s, etc., in groups, helps to keep the octaves in tune. It has hitherto seemed impossible to build an instrument which would play true diatonic scales in all keys, so equal tempering is used as a compromise. However, the tendency of vacuum tube oscillators to "pull in" to a frequency harmonically related, makes it possible for a tube to be a diatonic C# in one chord and a diatonic Db in another. This may account for the beautiful tone of this instrument.

TONE QUALITY

Tubes having no bias produce a beautiful "string" tone, but a small suggestion of keyclick is present. Capacity connected across the output transformer changes this to "diapason" tone, with no keyclick, and still more capacity produces a clear "flute" tone, which is so free of harmonics that it sounds much better with an octave coupler (i.e., 100% second harmonics. 2mf. across the primary of the audio transformer described above, or .15 mf. across the secondary of an ignition coil will do). Changing

the amount of *air gap* in the output transformer alters the tone quality. New tonal effects can be produced by *saturating the cores* of two amplifier transformers connected in series, Fig. 2. Primaries aiding, secondaries opposing, cores saturated equally, adds a *second harmonic*; primaries opposing, secondaries aiding, core legs saturated unequally, adds a *third harmonic*. Also full-wave rectification, followed by passage through a transformer, changes the tone; a pentode with wrong values of voltage on its grid produces striking effects. In these cases, while a single note sounds fine, when other notes are added to form a chord the non-linearity of the system produces cross-modulation tones, which create unbearable harshness, so these tones must be limited to a single note at one time (e.g., by a *melody coupler*, or use of a separate channel for each note, like the Rangertone.)

COUPLERS

Some type of *coupler* is necessary in order to make one manual (Melody or Great) sound louder than the other manual (Accompaniment or Swell). Sub, unison, super and two octave higher couplers, as well as the twelfth and seventeenth require seven contacts per key including the feed (see Fig. 1). If you desire unified fake stop names they could be called Bourdon 16', Diapason 8', Flute 4', Piccolo 2', Nazard 2 2/3' and Tierce 1 3/5' with the connections such that when middle C25 is played C13, C25, C37, C49, G44 and E53 as the case may be, sound. They produce the sub fundamental, fundamental, second harmonic, fourth harmonic, third harmonic, and fifth harmonic respectively.

When used in conjunction with other types of stops e.g., reed, electrostatic, electromagnetic, or photoelectric, it is an advantage to have the electron tube oscillator tones available in two or three different intensities. Three intensities may be obtained from two stops when wired by F. Gaskell's system, using a S.P.D.T. switch on the *soft* stop and a D.P.D.T. switch on the *loud* stop, see Fig. 3. This makes it louder to add a soft stop when the loud stop is on, a thing not true of some commercial electric organs.

Systems for Controlling Pitches—The Novachord uses iron core high Q oscillator coils for the top octave, and subdivides their frequencies for the lower octaves. Rangertone stabilizes the bass with tuning forks and *doubles* their frequencies for octaves.

Instead of 48 tubes for 4 octaves, 12 would do if they were dual triodes (6A6, 6N7, 6C8 or 6F8) and George's double contacts were used. This depends on the principle that two adjacent notes are rarely required simultaneously, so for C the tube is rendered operative while for C# it is rendered operative and the frequency changed by the additional contact. (See Patent 2,203,432.)

The results obtained from tube oscillators can be duplicated by other sources, e.g., rotating tone generators, and *much more striking effects can be obtained from the tubes used as keying controls*. For this reason the writer no longer uses tubes as oscillators, but has converted them to keying controls and highly recommends them for this purpose.

Part II—Conclusion in Next Issue.

Electronic Organ

Let's Hear from YOU—Electronic Organ FANS!

The Editors are anxious to receive articles on simple vacuum tube organs, as well as the more complex.

A New Type of Service Manual!

RADIO CIRCUIT MANUAL — 1941



**The Only EDITED Manual
Ever Published!**

DIRECTORY OF RECEIVERS MANUFACTURED IN 1940 AND UP TO JUNE, 1941

**MORE INFORMATION IN HALF THE
NUMBER OF PAGES**

The value of a service manual is measured not by the number of pages but by the amount of useful information. Thus, in only 736 pages this Radio Circuit Manual covers over 200 receiver models MORE than does any other competitive manual in twice the number of pages.

HOW DID WE DO IT? . . .

. . . . By increasing the size of our page; by discarding non-essential data and editing the balance; by listing only those receivers which the Service Engineer will definitely have to repair (no communications or export receivers, no shortwave sets or amplifiers, no electronic devices, etc.); by many months of hard work based on a definite plan of procedure and a clear understanding of the actual requirements of the Service Engineer. There is no "dead weight" information to add bulk to this Manual. Every word counts. Every minute of reading time is well spent.

OUTSTANDING FEATURES

- Contains data on more than 1800 receiver models!—more than any other radio service manual.
- Only 736 pages!—less than half the bulk of any other manual and more than 1/3 lighter.
- All information is EDITED!—all non-essential data deleted and the balance checked and correlated with the schematics and sketches.
- 40% larger page permits listing of all information on one page. (A few unavoidable cases excepted.)
- I.F. peaks for all superhet circuits are boldly displayed in black boxes—none missing, all accurate.
- No space wasted on communications and export receivers, amplifiers, electronic musical instruments, etc.—a 100% Service Engineer's Manual.

A "CUSTOM-TAILORED" MANUAL FOR SERVICE ENGINEERS

Here, at last, is a Service Manual deliberately PLANNED for the Service Engineer. Instead of a mere hodge-podge collection of service data, as manuals have been in the past, this RADIO CIRCUIT MANUAL is an orderly compilation of essential radio diagrams and service information, carefully edited and uniformly presented for the maximum convenience of the busy Service Engineer. All time-consuming, non-essential data have been weeded out, and the remaining information, vitally important to the rapid and efficient servicing of modern radio receivers, has been laid out in a logical, easy-reading style which cuts time from the day's work. Because of this and other features which are self-evident upon first observation, it has been possible to list all information pertaining to a given model on a single page.

In 736 pages this Manual presents essential service data on over 1800 receiver models!—more than any other existing service manual on the market!

ONLY ONE MANUAL PER YEAR!

The new technique used in compiling this RADIO CIRCUIT MANUAL—1941 makes it possible to include in a single book all the new receiver models which the radio industry can produce in a single year. This factor alone represents an important saving to all Service Engineers.

A PERMANENT INSTITUTION

This Radio Circuit Manual—1941 is NOT a one-time proposition. Next year there will be a Radio Circuit Manual—1942, the following year, 1943 and so on indefinitely—each Manual better than the other as new methods are worked out for expediting and simplifying the work of the practicing Service Engineer.



OUR NEW MANUAL—Lighter, compact, easy to handle, takes half as much room on the shelf, more USEFUL information despite fewer number of pages.

← THE OLD TYPE MANUALS—Bulky, heavy, hard to handle, space consuming, less USEFUL data despite greater number of pages.



MANUALS NOW READY!

RADCRAFT PUBLICATIONS, INC.,
25 West Broadway, New York, N. Y.

Gentlemen: Enclosed find my remittance of \$10.00, for which send me, POSTPAID, my copy of the RADIO CIRCUIT MANUAL—1941.

Name

Address

City State

RC-5-42

(Send remittance in form of check or money order; register your letter if you send cash.)

ORDER YOUR MANUAL IMMEDIATELY — NOW!

Get your copy directly from us by filling out and mailing the convenient coupon shown at left, or get it directly from your favorite distributor.

736 pages; size 13 1/4 x 10 1/4 x 2 in. thick; loose leaf, leatheroid-covered stiff binder; net weight 6 1/2 lbs.

ONLY
1000

RADCRAFT PUBLICATIONS, INC.
25 WEST BROADWAY NEW YORK, N. Y.

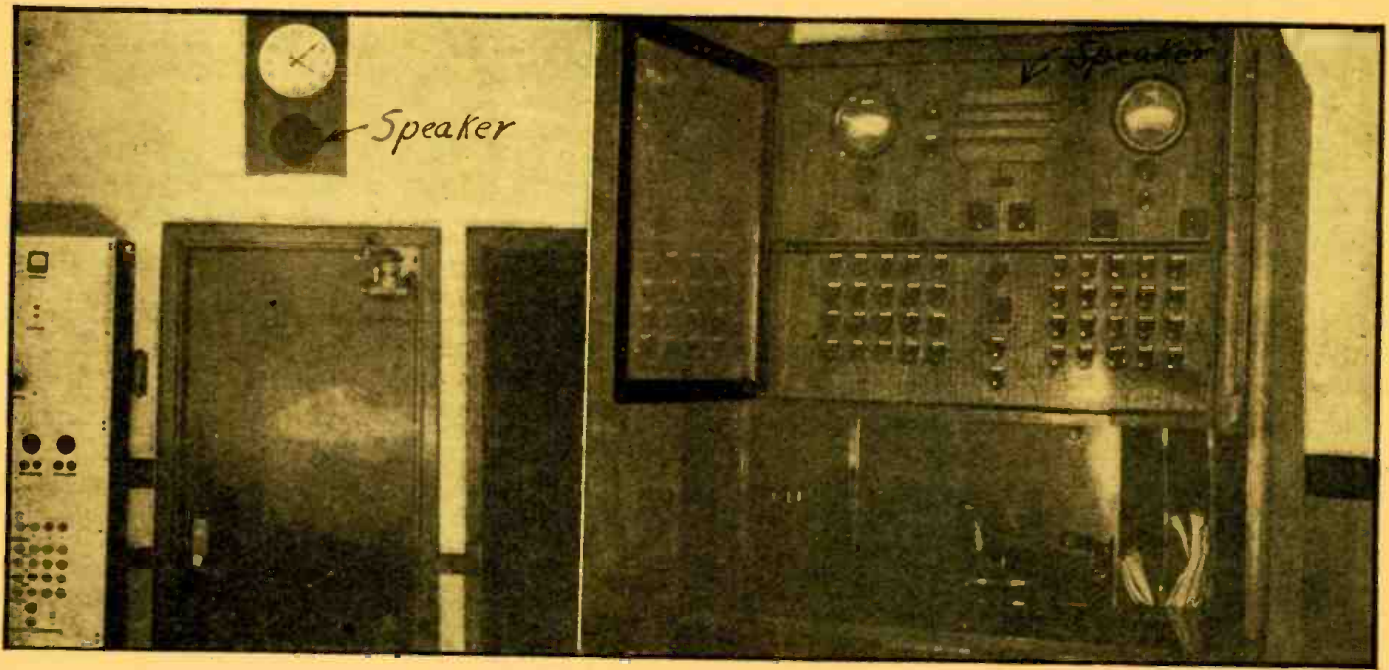

The photos at left and above show the Sound System installed at the Midland Senior High School, Midland, Mich., and here described by Prof. Moore, Instructor of Physics. The circuit arrangements shown in the diagram on the opposite page will be found interesting to all sound service installation men.

A MODERN HIGH-SCHOOL SOUND SYSTEM

THE sound system in the Midland High School is of the two channel type. Each channel contains a multi-wave super-het tuner and a 30 watt amplifier. The speaker circuits from each of the 49 class rooms, shops, auditorium and the gymnasiums terminate at the central panel in the principal's office. At the principal's office any room may be switched to either channel. The microphone circuits all terminate at the central panel and they can be switched to either panel. The central panel contains a monitor speaker, which can be used to "listen in" on radio programs or programs originating in other rooms. The monitor speaker can also be used to make announcements to other rooms. The sound system contains an emergency switch so that the principal can turn one switch and reach all rooms, regardless of the setting of the individual room switches. The central panel contains a vis-indicating device which indicates the approximate level or volume of the sound reaching the rooms.

SPEAKERS

All speakers are the permanent-magnet dynamic type, because of reversing the speakers for use as "microphones" during *talk-back*. The speakers in the ordinary class rooms are 1/3 watt. The speaker is flush mounted and enclosed in a panel with the clock in each room. When possible the speaker should not be installed in such a position that it faces the windows. The reflection from the windows will set up echoes in the room. Lowering the venetian blinds and closing them only partially will help to break up these reflections. In those rooms where noise-level is high, probably a 3 or 5 watt speaker is desirable. After one has been listening to a high level of

MAHLEN MOORE

Instructor of Physics, Midland, Senior High School (Midland, Michigan)

noise, the ear appears quite insensitive to sounds of ordinary level for a few minutes. During these few minutes an announcement may be made and students will miss it unless a higher wattage speaker is used. The speakers in the gymnasium are 5 watt speakers mounted in an aluminum baffle. Probably some deadening material should be used on the baffles to destroy the natural resonance of the baffle. The auditorium speakers are 15 watt high fidelity speakers in exponential-horns, to give them a more uniform frequency response.

Any serviceman knows that only rosin core solder should be used on such installations. Flux or paste causes a chemical deposit which blocks the circuit. If some slips in we have found an easy way out, especially if the trouble is in a speaker circuit: disconnect the speaker from the amplifier and connect in a 10 watt lamp in such a way that the 110 A.C. flows through the lamp and through the speaker circuit. The alternating current will fry out the chemical deposit; and so far as we know, the deposit will not form again.

MICROPHONES

We are using dynamic microphones with a modified velocity section. In the auditorium we are using both floor outlets for microphones on the stage and outlets for suspended microphones above the stage. Since the angle of coverage for a microphone is small, we are using three microphones suspended from above and so directed that they will cover the stage. The

microphone circuits should consist of two wires, and not a single wire and its shield as a two wire circuit. The latter was tried in our installation and it stood inspection O.K., but when other A.C. circuits began operating in conduit near the microphone circuit, we had a nice A.C. hum. We found what it was by disconnecting the microphone from its circuit; the hum was present. Then we disconnected the microphone from the amplifiers, and the hum was gone. This meant that the pick-up was in the microphone circuit from the mike to the amplifier.

When this happened we were in the middle of a dedication program, so we ran an ordinary drop cord around through the rooms to the microphone, and finished our dedication with this microphone circuit. Next day we pulled one more wire into each microphone circuit and *grounded* the shield on each wire. We have had no further trouble. We know that the *one-wire practice* is a common one in remote radio hook-ups, but in permanent installations, we would not take the chance.

When microphones are to be switched from one amplifier to another, both sides of the microphone circuit should be switched. We are using a microphone outlet in the auditorium projection booth to be attached to the sound head on a sound projector. The pickup from here will be sent to the central amplifiers and then back to the auditorium speakers. In the gymnasium the pickup may be sent to the gymnasium amplifiers, or it may be sent to the central amplifiers and from here to the class rooms.

VOLUME CONTROLS

Volume controls should be used on the large speakers in the "gym" and the audi-

torium. They probably should control the volume from 50% to full volume and not from 0 to full volume. If they control from 0 to full volume and someone sets them at 0 volume, this is equivalent to turning the speaker off; then the principal cannot reach the room through the sound system. Older teachers who do not like new-fangled ideas are quite liable to do this. When dual volume controls are used, such as shown in the diagram of the auditorium, you must switch-out both the amplifier and the speaker side of the volume control when the control is not in use. The reason for this is that the volume controls are in parallel and if one of the controls is at low volume, the volume will be low, regardless of where the other volume control is set. Volume controls that are to be adjusted frequently should be in locked compartments, where students cannot tamper with them. Other volume controls can be in back of the speaker grill. Probably 1/3 and 3 or 5 watt speakers can be used

without volume controls on the large speakers, if the proper impedance-matching transformers are used.

SUPERVISORY SYSTEM IN THE MUSIC DEPARTMENT

This is not shown on the diagram, but the music department has six small prac-

supervisor can listen in and give instructions to each student, without wasting his time going from one room to another.

RECORDING EQUIPMENT

It appears that recording equipment would be quite practical for a school. The social science classes like to listen in on the President's address to Congress, etc.; but during the time the President is speaking, only one or two social science classes are meeting. We have tried sending the speech to all the rooms, but this disturbs all the classes. The best solution that we can see is to have a recorder and make a record of the speech. Then the record can be played in any or all of the social science classes and the teacher can stop and point out important parts that are to follow, or they may replay important parts. This recorder would be used by the vocal and instrumental music departments. It would also be used by the "public speaking" department.

THE EDITORS WANT
 more articles, such as this one, on Practical Sound Installations and Operating Hints. Tell us the principal features in your own way . . . type the manuscript if possible . . . draw the diagrams neatly with pen or pencil . . . enclose clear photos . . . We'll do the rest!

tice rooms and there is an inter-office communication system between these rooms and the instructor's office. Thus the students are separated for practice and the music

Wiring diagram of the sound installation at the Midland Senior High School, Midland, Mich.

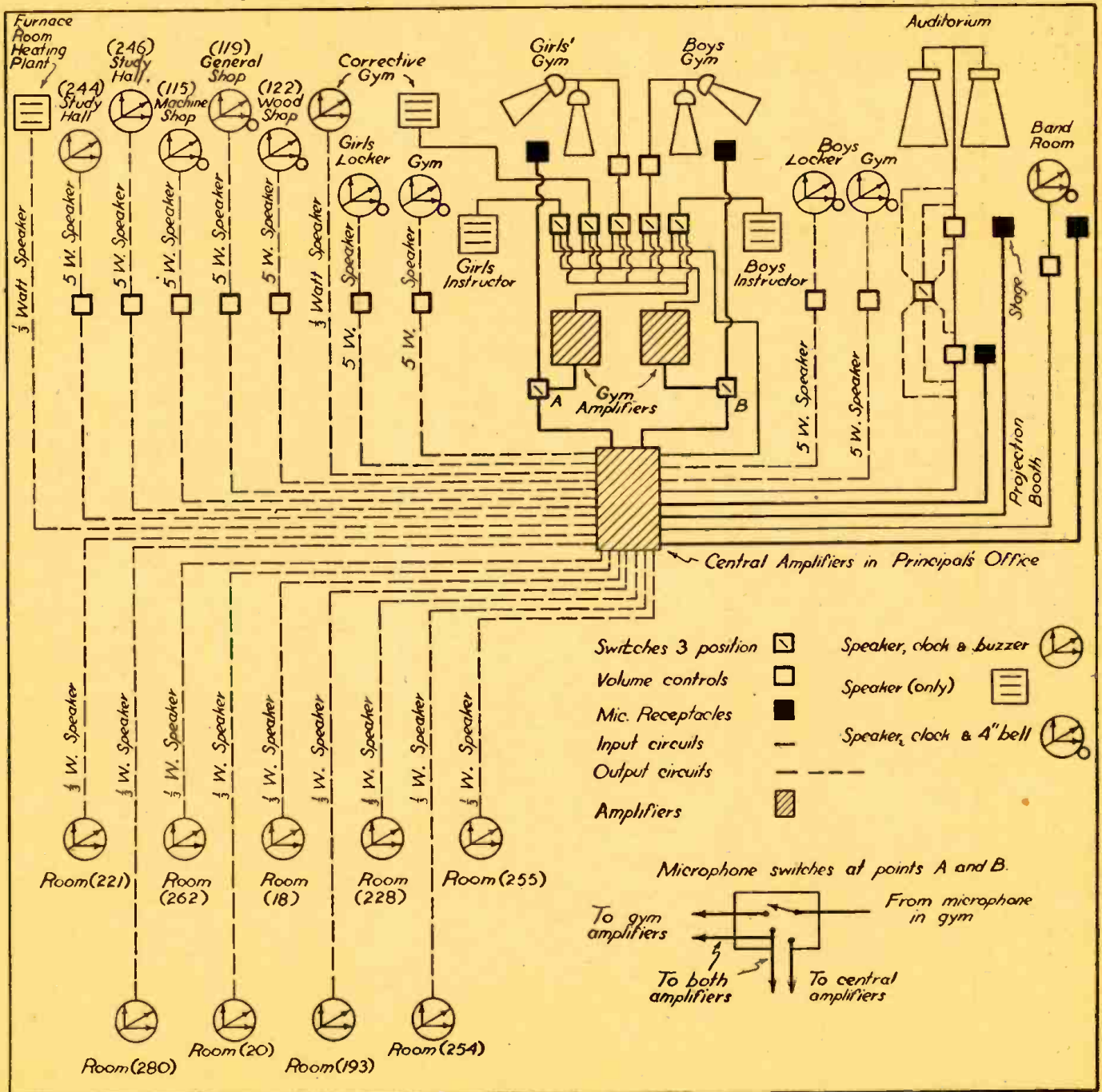

What Happens in Resonant Circuits?

WILLARD MOODY

The action taking place in a resonant "tunnel circuit" in a radio receiver or other similar apparatus is not very clearly understood by the average radio student. The accompanying specially-written article will, therefore, prove doubly welcome, the editors feel certain.

IN radio work parallel and series circuits of resistance, inductance and capacitance are encountered in many forms and combinations; hence the student beginning the study of complex circuits will find it useful to have a clear conception of the fundamentals. The theory of the resonant circuit is particularly important.

When an electric current is passed through a wire, a circular electromagnetic field is created which has its radius point started at the center of the wire as shown in Fig. 1. The effect of this field is primarily important. Lenz's Law states that the effect of a change in current in the wire is to produce an electromagnetic field change which will tend to limit the increase of current in the wire, and that once the current has increased to a certain value and starts to decrease, the effect of the electromagnetic field is to prevent the decrease, or to oppose any change. This property of opposing a change in the electromagnetic field or in the current is termed inductance. In practical work the wire may be coiled so as to concentrate the electromagnetic lines of force and we have a "lumped inductance" or coil.

Capacitance is primarily the ability to store or retain electricity. If we take a condenser and connect it to a battery, electrons leave the negative pole of the battery and flow into one condenser plate. The other condenser plate is charged with positive electricity. The result is that an electric "field" is created between the two plates and the energy of the electrons which left the negative terminal of the battery has the effect of "flexing" the electrostatic force lines between the plates and of transmitting energy from the negative plate to the positive plate. This energy then sets in motion the electrons in the positive plate and an electronic movement exists from positive condenser plate to positive battery pole. If the electric stress is created as the result of application of and then removal of potential, the condenser will be "charged."

The coil, an inductance, stores energy due to its electromagnetism and the condenser due to its electrostaticism.

In a radio receiver we frequently find that the antenna is connected to a primary coil on a radio frequency transformer. Across the secondary of the transformer we have a tuning condenser. In parallel with the coil

and the tuning condenser we have the tube input circuit, which we may consider has a simple equivalent shunt capacity effect on the L/C circuit.

WHAT HAPPENS IN A TUNED CIRCUIT

Many students find it difficult to visualize just what happens when the circuit is tuned to a station's frequency and a signal is picked up. As the radio wave strikes the antenna, the flexure or movement of the electromagnetic wave causes a current to be set up in the antenna. This current then flows in the primary coil of the transformer. The electromagnetic field about that coil links with the secondary and the force lines, being flexed, induce a current in the secondary coil. The coil has the effect of retarding the flow of current, due to its property of inductance and when the current tends to rise in the coil, it is opposed by the electromagnetic field around the coil, which reacts back on the current and produces a "counter-electromotive force." This force is a potential opposite to the impressed voltage, limiting momentarily the growth of current in the circuit. Thus, the current is said to "lag" the voltage in the coil.

Mr. Moody explains the action of the "circulating current" in a resonant circuit, with the aid of the accompanying diagrams.

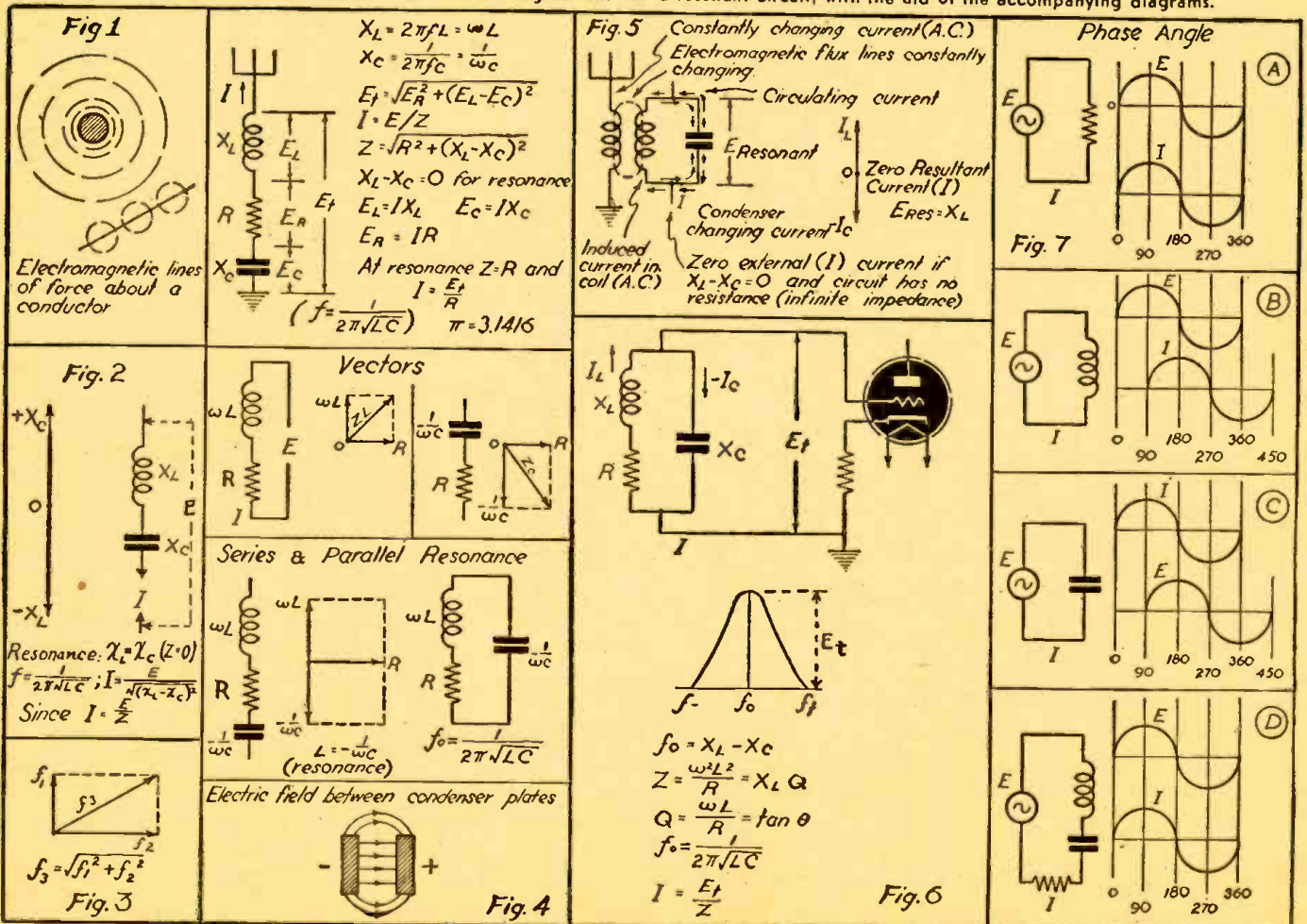

RADIO MEN! THE "MARINES" WANT YOU!

Lucrative positions are being offered by the United States Marine Corps to radio specialists between the ages of 17 and 35 who can qualify.

Radio men in this democracy are being urged by their government, through the United States Marine Corps, to help win the war. The leathernecks want all kinds of radio men, from amateurs, right on up to experienced technicians. There's real money in it, too, for men who qualify and make the grade.

Any radio hobbyist, technician, repairman—or even a "ham" operator—between the ages of 17 and 35 who can measure up to the qualifications specified by the "devil-dogs", can take advantage of this opportunity to aid his country and to make some money for himself by enlisting at the nearest Marine Corps recruiting station, as either a Regular, a Class III (c) Reserve, or a Class V (b) Reserve.

Here's the official word from Marine Corps Headquarters:

Any physically fit man from 17 to 35 who holds or has held an Amateur Radio Operator's License, Class A or B, or a Commercial Radio Telegraph or Telephone Operator's License, First or Second Class, or has certain experience qualifications, can enlist in either of two groups.

In order to make the first, or special radio duty group coming under the Class V (b) Reserves, a radio man must have a high school diploma. And if he hasn't held the licenses called for, he still can qualify. At least three months' experience in radio repairing and servicing, or work in connection with designing or constructing high frequency or ultra high frequency transmitting or receiving equipment, will put him in this special class, providing, of course, that he's a high school graduate.

With what is called a special warrant, such men will be ranked as Staff Sergeants right after enlisting, without having to go through recruit training. They will be assigned immediately to a signal battalion for special training in Radio Aircraft Warning maintenance, known as RADAR.

The second opportunity covers those who haven't finished high school but who can qualify as to the license requirements applying to the special warrant group, or if they lack those, can meet the specifications on the basis of a certain amount of practical experience.

This experience can be actual repair and service of radio equipment for at least three months. They can join the Marine Corps either as regulars or reserves. The reserves in this group would come under Class III (c).

These men, without a high school diploma but with some practical radio experience, are sent through recruit training, just like men in line for general military duty. After learning marching drill and the correct Marine way of handling rifle, pistol and bayonet, they attend radio school to prepare themselves for general radio duties. Failure in radio school would put these men into general line duty, for they are not entitled to special rank upon enlistment.

Men in both groups, however, must meet the regular physical requirements for enlistment, although in special cases where a radio man's experience would prove exceptionally valuable, some of the qualifications might be waived.

Anyone interested in radio duty with the United States Marine Corps can go today to the nearest recruiting station or to his local post office.

However, as soon as an appreciable current flows in the coil, a potential difference builds up across it (impedance drop = $E = IZ$). This voltage is then impressed on the condenser, but the condenser has the property of requiring electrons to flow into its plates before it can assume a potential difference between plates. Thus, in the condenser the action is exactly opposite to the action in the coil. The current leads the voltage or the voltage "lags the current" in a condenser circuit.

MEANING OF "Q" AND POWER FACTOR

For a pure condenser or coil having no resistance the angle of lag or lead is 90 degrees. When resistance is introduced this angle is cut down. In a high grade coil or condenser we desire a phase angle as near to 90 degrees as we can get it. In radio work we express the phase angle of a coil in terms of "Q" and of a condenser in terms of "power factor." We desire HIGH Q and low power factor.*

The condenser, once it has become charged from the coil, tends to discharge through the coil and then the coil tends to return the energy to the condenser, so that in effect there is a continuous current transfer between coil and condenser, which we call the "circulating current." In a pure condenser or inductance no energy is wasted or lost, and once started the cycle would continue forever. In a practical circuit the coil has a certain amount of resistance and the condenser also has a small amount, so that power is lost in the circuit and new energy must be supplied to it from time to time. In an oscillator this supply of new energy comes from the anode or plate circuit and in our example it comes from the antenna, so that a "fly-wheel action" may take place.

As the result of the voltage lead of the coil and the voltage lag of the condenser, the effect of one is to cancel the other and to make the circuit behave at "resonance" in much the same way as a pure resistance. The condenser lag effect and the coil lead effect, with respect to voltage, is called reactance. The net reactance in the circuit is said to be zero at resonance. This condition holds either for series or parallel resonance. The diagram in Fig. 2 illustrates this principle.

At resonance in the parallel of series circuit, the voltage across the coil and condenser rises, due to the current flowing in the coil and in the condenser. In the parallel resonant circuit these heavy resonant currents balance out, in the series circuit the reactance of coil and condenser exactly balance at resonance but the current in each is identical.

Because for parallel L and C the current is zero externally, when neither coil nor condenser has resistance, the impedance of the circuit is practically infinite and the line current is zero.

In the series circuit there is zero impedance (if coil and condenser have no resistance) at resonance and the series current is infinitely great for an infinitely large value of applied voltage.

The use of simple vectors for showing direction of forces is helpful. A vector is a line which indicates by virtue of its direction and length the magnitude and direction of an electric quantity. If we have two forces acting at right-angles, the resultant force will be given by a diagonal as shown in the parallelogram of Fig. 3. Also, if two forces are acting in the same direction or in opposite directions, they will add or subtract, according to their relative positions.

$$\tan \phi = \frac{WL}{R} = Q$$

$$\cos \phi = R/Z = \text{Power Factor}$$

If we have a force of 10 volts acting in a north or positive direction and a force of 5 volts acting in a south or negative direction, the net force will be 10-5 or 5 volts.

The reactance of a condenser or of a coil may be stated in the form of mathematical formulas as shown in Fig. 4. The symbols used and their meanings are given below.

- I current in amperes
- E potential in volts
- Z impedance in ohms
- R resistance in ohms
- X_L inductive reactance in ohms
- X_C capacitive reactance in ohms
- φ Greek letter (thay-ta) represents phase angle in degrees
- L inductance in henries, mh (microhenry is henry/1,000,000)
- C capacitance in farads (mf. is farad-/1,000,000)
- ω Greek letter (o-mee-ga) represents 2πf
- f frequency in cycles, kilocycle is 1,000 cycles
- π a constant, being the ratio of the circumference of a circle to its diameter or 3.1416

When a parallel circuit of L and C is used in a radio receiver, the impedance of the circuit is a maximum at resonance and is essentially resistive. From ohm's law, we know that the voltage across any circuit is proportional to the product of the current times the resistance. If we know, and we do, that at resonance the line or external current will be a minimum and that the impedance will be infinite for pure inductance and capacitance in parallel (no resistance in the coil or the condenser) we can readily see that multiplying zero line current by infinite impedance will give a value of voltage across the tank that is also infinite. Because in practice we don't encounter perfect coils or condensers, i.e., units having zero resistance, and because the tube input capacity causes detuning and gas within the tube produces a conductive path, there is a certain amount of loading on the tuned circuit, which reduces the theoretical efficiency.

The paradox of infinite impedance at resonance, or very high impedance, and maximum signal seems difficult to grasp for some people. If the action is thought of in terms of energy the matter is greatly simplified. The time rate of energy is power—that is so many watts per second. If we assume simply that we have a certain voltage and current, we can readily see that if the current is reduced to zero (or a very low value) that the voltage in the circuit will rise to a higher value, assuming constant power. Thus, $E \times I$ equals W . At resonance we have a high current in either branch of L or C, but the net current is zero, since coil current is positive and condenser current is negative (vector quantities). Remember we are dealing with a voltage in such a circuit. It is the voltage that swings the grid of the tube (the tube is a voltage-operated device) and causes a plate current variation.

**ATTENTION!
SERVICEMEN!**

Tell the Editors what kind of articles you want!

Also send along an article of your own now and then, describing your "pet ideas" for War-Time servicing.

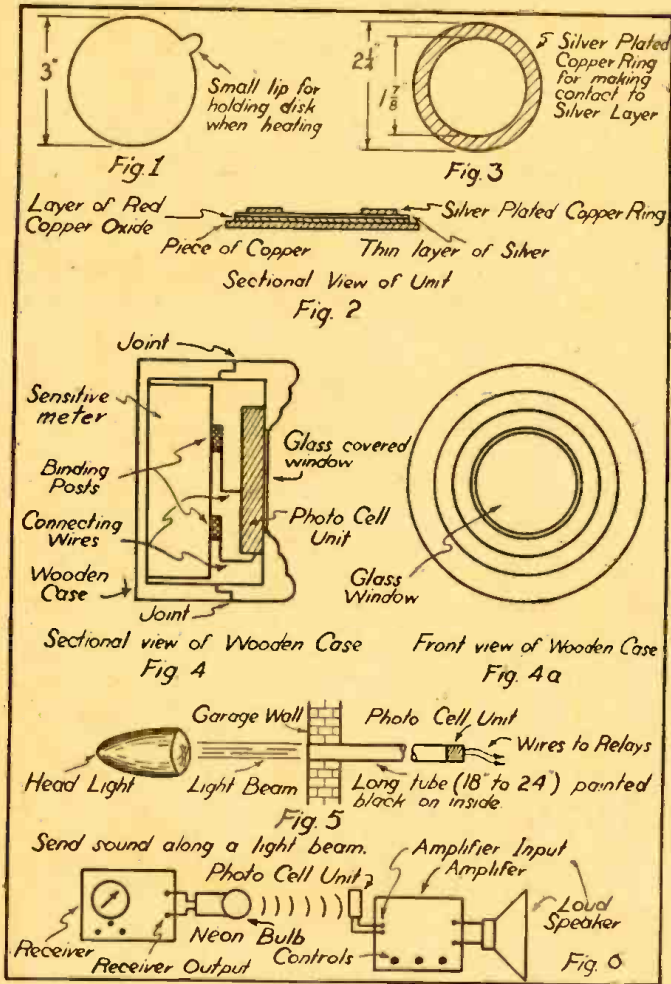

Constructing a Simple

PHOTO-ELECTRIC CELL

Not everyone can afford to buy a photo-electric cell and as every radio and electrical experimenter has at one time or another required such a piece of apparatus, the author has here described how to make your own light-responsive cell. The process is much simpler than you might at first imagine.

LOUIS CASTELLI

(1) Make up 10% solutions of the following:

Common Name	Chemical Name
(a) Caustic Potash	Potassium Hydroxide
(b) Rochelle Salts	Rochelle Salts
(c) Ammonia	Ammonium Hydroxide

Use distilled water for all solutions and keep them dilute.

(2) In 1 oz. of water dissolve a crystal of silver nitrate (lunar caustic) about the size of a match head.

Now to the solution of silver nitrate add some ammonia until it becomes clear after first turning brown. Add the ammonia slowly. Add a small amount (about 10 drops) of potassium hydroxide, then add NH_4OH until the solution is clear again. The last ammonium hydroxide should be added with an eye-dropper—a drop at a time so that too much will not be added. The best plan is to add one drop, and wait until it has finished reacting before adding another drop. This is a slow process but worth it. If too much ammonia is added it will dissolve the copper oxide. Now set the copper disk with the oxide side up on a level block. Then add a small amount of Rochelle salt solution to the silver nitrate, potassium hydroxide and ammonia solution. Then pour immediately onto the disk at the center. Since the disk is level the silvering solution will spread out evenly. Let the solution come to within an eighth of an inch of the edge of the copper oxide layer. This is to prevent a contact between the copper and the silver. Allow the silver to precipitate out and then pour off the remaining solution. The silver should then be sufficient so that when lightly polished with a soft cloth, the red oxide below shows through slightly.

To make contact to the silver a disk of silver-plated copper was used. The disk is slightly less in diameter than the outside diameter of the oxide layer and the silver layer. A circle was cut out of the center so that the actual copper ring was about $\frac{3}{8}$ of an inch across (see Fig. 3).

HERE is a description of a simple, inexpensive, yet effective photocell. The principle of this cell is incorporated in the photocells used in light meters and photographic exposure meters. It may be used to open garage doors or can be used for demonstrations of sending sound along a light beam, etc. The cell incidentally needs no external source of current, since it develops a current of its own.

Principle of the Cell: The principle of action depends mostly on the photo-electric properties and effects of various metals and their oxides (see page 42-52 *Elementary Chemistry*, Book 2, W. Littles, or some other high-school chemistry book). A layer of copper oxide and a layer of copper are in contact with each other and a current flows, due to the electron displacement in the copper oxide and copper when they are exposed to light. A layer of silver is placed over the copper oxide. It does not directly enter into the reaction, but it acts much as a catalyst does in a chemical reaction. It does not react but it causes a bigger current to be produced. The current flows from the layer of silver to the copper. Thus the silver contact is positive while the copper contact is negative.

Construction of the Cell: The first step in the construction of the cell is to cut a circular piece of copper ($\frac{1}{32}$ " thick) three (3") in diameter, leaving a small lip on it as shown in Fig. 1. The use of the lip will be explained presently.

The next step is to put a layer of copper (cuprous) oxide on the copper. To do this the copper must be thoroughly cleaned first with a piece of fine grain emery cloth. Then

flow the disc with nitric acid. Next, rinse in clean (preferably distilled) water. The next step is the actual forming of the layer of oxide. Heat the copper in a blow torch till red hot. Grasp the copper by the "lip" with a pair of pliers to do this. Move the copper about in the flame, so that it will heat up evenly over the whole surface. **A word of caution:** Do not allow the clean part of the copper to be scratched by the pliers or anything else, or the copper must be cleaned again and the layer of copper oxide will be uneven. When the copper reaches red heat, cool it by placing the oxide side upon some large steel anvil or machine table. A layer of black copper (cupric) oxide will be formed on top and a layer of red (cupric) oxide will be formed underneath this. The red oxide is the required oxide. If all of the black oxide does not chip off in the cooling process the portion that remains must be removed by the use of fine emery cloth or steel wool. **Do not scratch the red oxide** because if the red oxide layer is scratched, the whole process of cleaning and forming a layer of oxide must be repeated. (Don't be discouraged if the layer is scratched the first time; the author repeated the cleaning and oxidizing processes three times before the desired result was obtained.) As suggested heretofore, a current will be detected if a sensitive meter is connected to the copper and to the oxide. **Again be very careful not to scratch the oxide layer with the test prods.**

In order to reduce the contact resistance of the copper oxide and to produce a larger current, a layer of silver is deposited over the layer of oxide. To do this a special silvering solution is required. The solution is made up as follows:

The construction of a home-made photo-electric cell is made easy with the aid of the drawings here reproduced.

A method quite satisfactory for plating the copper with a layer of silver is to place the copper in a solution (dilute) of silver nitrate. A gray scum will collect about the copper and some of it will collect and plate on the copper. When the first scum has collected on the copper, remove the copper and rinse in distilled water. Then place in the solution again. Continue this until the copper is completely covered with silver. The copper ring can also be plated by using a solution of silver and potassium cyanide and a bar of silver as a positive electrode.

It is perhaps more satisfactory to enclose the unit in a wooden case, turned up on a lathe especially for the purpose. The silver side of the unit must face toward the light in order to have the device generate a current.

USES OF THE METER

(1) The unit can be used as an *exposure meter* by merely connecting the unit across a sensitive meter and calibrating the meter scale, by using some meter of standard manufacture as a calibrating standard. To make the meter easy to carry around it can be placed in a specially made wooden case, which can be turned on a lathe (see Figs. 4 and 4a).

(2) The unit can be used to open garage doors and by using the suggested hookup, the unit will operate both day and night (see Fig. 5).

(3) The unit can also be used to demonstrate the "sending of sound along a light beam." This is accomplished by connecting a neon bulb directly across the output of a receiver and having it focus onto the photocell, which is connected to the input of a small amplifier. The variations in the voice current at the output of the receiver are manifested as variations in intensity in the light emitted by the neon bulb. The neon bulb will follow these rapid variations. When the photocell picks up these variations in intensity of the light, it re-forms the light variations into changing varying electric current, and this is amplified by the amplifier and changed into sound again by the loudspeaker (see Fig. 6).

THE EDITORS WANT

good **constructional** articles (with clear photos and diagrams), Radio Receivers and other sets, especially "FM" Tuners and Adapters. We also are anxious to see constructional articles on Short Wave Receivers; also general articles on Antennas, etc.

Kits for DEFENSE RADIO TRAINING

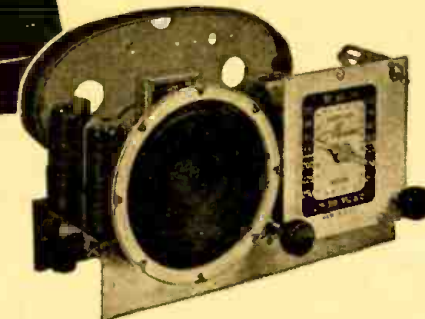

5-Tube AC-DC Super-het Kit

Using a small number of tubes, this Meissner engineered 5 tube AC-DC super-het is compact in size and contains a factory wound loop antenna. Only two controls are used, making the set very simple to operate. It's simple to build . . . you can easily follow the schematic and pictorial wiring diagram. The Kit is complete—there is nothing else to buy. Kit with tubes—\$31.25 list.

5-Tube AC T. R. F. Kit

Here's a Kit that is low in cost and high in quality. Operates from 110 volt 50-60 AC with a frequency range of 530 to 1600 kc. (187 to 565 meters). Complete kit includes all parts necessary for construction of the receiver with exception of tubes and speaker. Meissner pictorial diagrams make this set extremely easy to build. Kit—\$27.00 list.

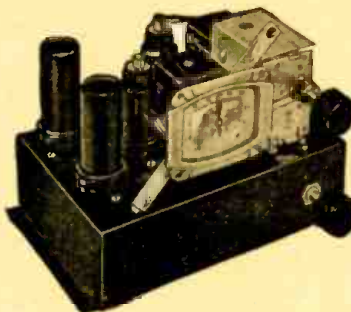

4-Tube AC-DC T. R. F. Kit

Here is a very small compact receiver with exceptional sensitivity and tone quality. Frequency coverage of 530 to 1600 kc. Compact, high gain shielded coils are tuned with a two gang precision tuning condenser. Provision for mounting 5" dynamic speaker. Kit contains all parts except tubes and speaker. Pictorial diagrams aid you to construct this receiver easily and quickly. Kit—\$19.50 list.

See your nearest Meissner jobber. Write for complete new catalog.

Address Dept. CT-5.



MT. CARMEL, ILLINOIS

"PRECISION-BUILT PRODUCTS"

NEW SAN FRANCISCO SHORT-WAVE STATION

O. F. Walker, radio engineer of the General Electric Company, has been supervising the installation of a 100,000-watt short-wave transmitter in San Francisco, which will be another gun in a kilocyclic battery "shooting" from the United States across the Pacific in the propaganda war with Japan.

The powerful transmitter, built by General Electric and operated previously at its Schenectady station WGEO for short-wave broadcasts to Europe and Latin America, will be operated in San Francisco under call letters KWID. Operators of the station will be Associated Broadcasters, Inc., operators of long-wave station KSFO. General Electric is completing another 100,000-

watt transmitter for WGEO at Schenectady and meanwhile is on the air there with two other short-wave transmitters, WGEO and WGEA.

KWID, which will have studios and offices at the Hotel Mark Hopkins, will render additional short-wave service to that now being given by General Electric's 50,000-watt San Francisco station KGEI, with studios and offices at the Fairmont Hotel. KGEI has been broadcasting to Latin America, Asia, the Antipodes, and Africa for more than three years, and is at present the only United States short-wave broadcasting station west of the Mississippi. KGEI is now broadcasting in eight languages and two foreign dialects.

HOME-MADE ARC LAMP

JOE NONWICZ

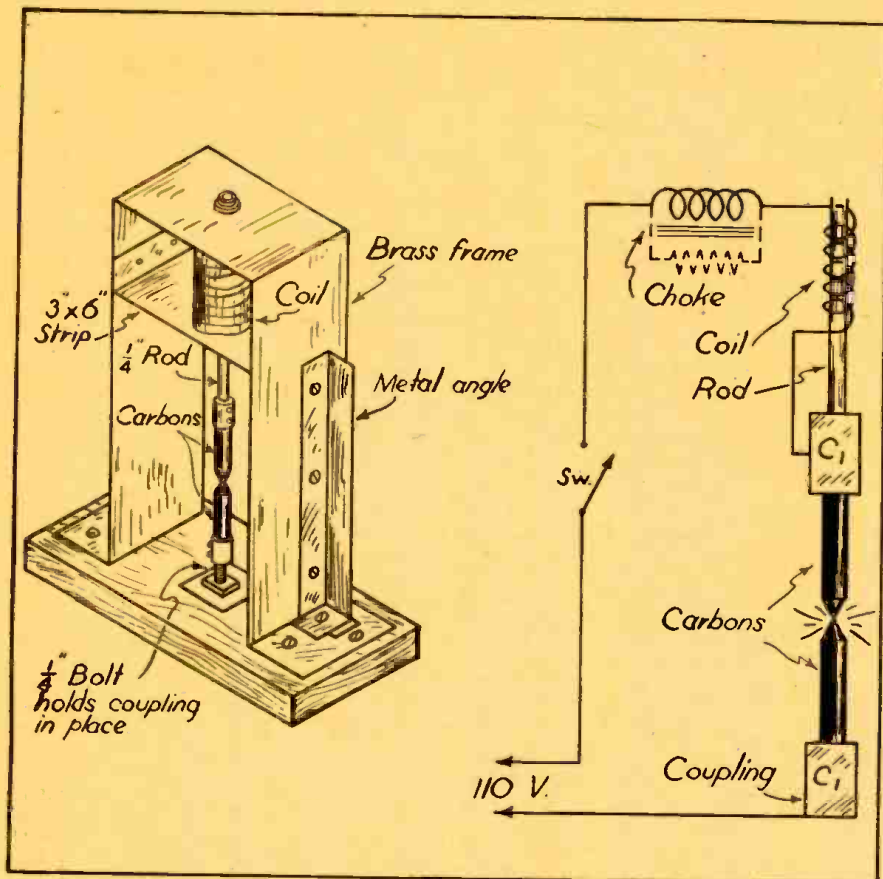

From a few scrap parts easily found in your "junk box," this home-made arc lamp can be constructed.

THIS simple arc lamp with automatic feed is suitable for use as a sun tan lamp, and can be built entirely of junk parts found in the average experimenter's shack.

The frame for the lamp is made of a strip of metal 3" wide and 32" long, another piece 3" wide by 6" long is needed to hold in place the porcelain tube on which the coil is wound, and two more 2" by 10" strips are required for braces. The base is a piece of 1" by 12" wood, which must be large enough to house the lamp, the switch, and the choke or resistance, whichever is used. A 7/8" piece of 1/4" iron rod together with the coil serves as the automatic feed. Two condenser shaft couplings 1/4" to 3/8" or 1/4" to 1/4" (the size depending on the size of the carbons used) are the carbon holders, the 1/4" to 3/8" size being suitable for use with flashlight battery carbons, since they are about 3/8" in diameter.

Construction is started by drilling 1/2" hole in the center of the 3" by 32" strip and also in the center of the 3" by 6" piece, both of these strips are then bent to make a right-angle 2" each side of center, then 2" from each end of the 3" by 32" strip, another right-angle is made. A porcelain tube of the type used in wiring is now inserted into the hole in the frame and the 3" by 6" piece of iron or other metal is so placed inside the frame, that the bottom of the tube is even with the bottom

of the strip. This position is marked and holes are drilled for bolts to hold it here. A hole slightly larger than 1/4" is drilled in a 1 1/2" by 1 1/2" piece of brass and a 1/4" bushing is mounted directly over the hole and the whole piece is bolted onto the 3" by 6" strip directly over the 1/2" hole. The braces are made by folding the two 2" by 10" strips lengthwise into a right-angle, and then cutting along this fold for 1 1/4" and folding these two halves into a box corner, holes are then drilled in the braces and frame and the braces are bolted to the base. A piece of asbestos is put over the hole of the frame, the porcelain tube is inserted and a coil of about ten layers of No. 16 wire is wound on the tube. The 3" by 6" piece with the bushing on it is now bolted in place and the frame is bolted to the base. The rod is inserted into the coil, the place where the rod touches the base is marked and a 1/2" hole is drilled here. A 1" piece of 1/4" bolt is put through a 1 1/2" by 1 1/2" piece of brass, which is bolted to the base so that the bolt falls directly over the 1/2" hole in the base. Condenser shaft couplings are now put on, one on the shaft and the other on the 1/4" bolt, carbons are inserted into the empty ends of the couplings and the lamp is wired according to the diagram.

When the lamp is wired plug it into the 110 volt outlet and turn it on. The lamp should strike an arc and keep it going, but if the arc does not strike and the ends of

A self-feeding arc-lamp suitable for sun-tan treatment, etc., is illustrated and described by the author. Standard arc carbons are used and the cost of building the lamp is very low—a good "defense" project, as it can be built from "scrap box" parts.

the carbons get hot, this means that the rod or the carbons are too long. When this happens, the rod or carbons should be shortened, but care should be taken not to cut too much of the rod off, as it will fall out of the coil when the carbons burn down.

If the lamp is to be used on D.C. a resistance of about 6 to 11 ohms should be substituted for the choke. If the lamp is turned on and the top carbon jumps up and down without striking an arc, the carbons are too large and smaller carbons should be substituted.

The lamp will work entirely without attention, once the proper size and length carbons are in place, as the solenoid (suction) coil will lower the top carbon automatically as the carbons burn down.

The iron rod which holds the carbon and which slides freely in the coil is 7/8" long, so theoretically it would be possible to use carbons 1 3/8" long, since the coil would pull the iron rod up until the rod was in the center of the coil, but I use carbons approximately 2" long as part of each carbon is taken up by each coupling, thus leaving a little less than 1 5/8" of useful carbon. When the lamp is turned on, the resistance between the carbons is very low; this causes the carbon to jump up since the coil current is high, thus striking the arc. Sometimes the carbon doesn't vaporize instantly and the carbon jumps up and down, but once the carbon vaporizes and the arc starts, the lamp keeps a steady arc going, because as the top carbon gets too close to the bottom one the resistance is lowered and more current flows through the coil. This increases the attraction of the coil for the rod, thus raising the iron rod to which the carbon is attached and thus pulling the carbons apart, until the coil current drops to a certain value, at which the carbon becomes practically stationary. As the carbons burn down the resistance increases and the coil current drops, causing the carbon to drop until a certain current value is reached, when the carbon again becomes practically stationary.

Those interested in making a very smooth-working arc lamp will do well to study one of the commercial arcs. Pay special attention to the simple, but effective design of the clutch used to lift the carbon in the commercial apparatus. Also a dashpot is desirable to prevent the spasmodic, jerky action of the arc mechanism usually encountered when the dashpot is not employed.

Also experiment with the amount of resistance in series with the arc; increasing this ballast resistance will sometimes vastly improve the action of the arc.—Ed.

Build Your Own

Automatic VOLTAGE REGULATOR

High-class receivers, such as those of the "Communications" type, require a fairly constant line voltage for their proper operation. The automatic home-built voltage regulator here described by Mr. Taylor was found on actual test to hold the line voltage extremely constant.

S. GORDON TAYLOR

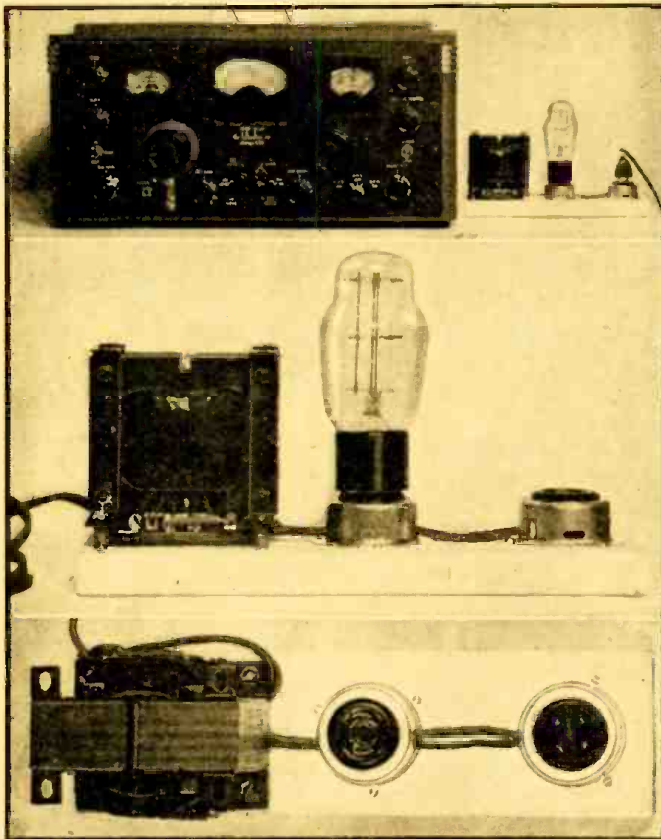

Fig. 2
One of the photos shows the voltage regulator at right of SX-28 receiver. Other photo shows appearance of home-built automatic voltage regulator.

ALMOST everyone whose interest in radio extends beyond that of the ordinary radio listener realizes the disadvantages of fluctuating line voltage when applied to a radio transmitter, receiver, test oscillator, vacuum-tube voltmeter or almost any other line-operated radio or test equipment. Usually if one finds that his line voltage varies materially from hour to hour or day to night, he simply considers himself unfortunate—and suffers in silence.

If he is a ham whose transmitter tubes require constant filament voltage for proper life and operation, he sticks a rheostat and voltmeter in the circuit and, keeping an eagle eye on the voltmeter during operation, manually adjusts the rheostat from time to time as line voltage variations require. If he is either a ham or *short-wave listener* he may find that his *communications type receiver* varies in sensitivity, or if it has an "S" meter, that the zero setting of this meter refuses to "stay put," with the result that he must make frequent adjustments of the zero-setting control if the meter is to continue to give anything like its normal indications for given signal inputs. In test work any test equipment which employs vacuum-tubes will very probably have its calibrations thrown off when the line supply voltage varies.

It isn't by any means necessary to grin and bear such bothersome variations. At very little cost anyone who has the ability to build and wire the simplest type of radio equipment can build himself an *automatic line-voltage regulator* that will do an excellent job. The simple unit to be described here, for instance, proved capable of holding the voltage applied to a *communications receiver* constant within plus or minus 2 volts, with the line varying between 105 and 130 volts.

The heart of this regulator is the Amperite self-adjusting line voltage control. In appearance this is similar to a 6L6G tube, but its internal element is a grid of resistance wire which has as its most notable

worthy characteristic the ability to automatically vary its resistance over a wide range in order to maintain current flow constant. Thus, this is a real "ballast" tube and is not to be confused with the resistance tubes employed in many AC/DC receivers, sometimes incorrectly called "ballast" tubes, but which in reality are just another form of fixed resistor.

When a ballast tube is connected in series with the load to be controlled, a rise in line voltage will cause the resistance of the Amperite to increase. This in turn results in an increase in the voltage drop across the tube approximately equal to the increase in line voltage. The voltage applied to the load therefore remains unchanged. On the other hand, should the line voltage fall below its normal level the resistance of the ballast will automatically decrease, and also the voltage drop across it.

One can think of these ballast tubes either as constant-current devices, or as voltage regulators. The important thing is not the terminology but the performance. The performance characteristic of a typical Amperite is shown in Figure 1. Here it will be seen that as the applied voltage is increased from zero the current flow increases rapidly at first, then remains constant during continued voltage increase and finally again starts to rise. The best regulation is, of course, obtained over the flat portion of the current-voltage characteristic which, in the particular ballast represented in Figure 1 (and applies to all other ballast as well) shows variation of 200 percent or more in the voltage drop for a 10 percent change in current flow.

The ballast tube always presents some resistance to the circuit in which it is included. Thus if the ballast of Figure 1 were included between a 115-volt line and a load rated at 0.63 amp., 115 volts, the load would not receive its normal voltage, but instead would have applied to it the voltage of the line, less the drop across the Amperite. In order to apply 115 volts to the load, therefore, it is necessary to first provide means

for stepping up the line voltage to a higher level. An alternative would be to include in the controlled device a power transformer having a primary rating of some value lower than 115 volts.

From the curve of Figure 1 it is seen that at the midpoint of its flat portion, there is a drop of 20 volts across the ballast. If a transformer were connected to first raise the line voltage by this amount then the voltage applied to the load would be the required 115 volts. Or the transformer in the load could have a 95-volt primary, in which case the load would receive its proper supply from the 115-volt line, after the ballast drop.

It is rather difficult for the home constructor or experimenter to alter the primary winding of the power transformer in the receiver or other equipment to which the control is to be applied. It is a simple matter, however to step up the line voltage to the required higher level by means of a small transformer, which adds anywhere from 20 to 25 volts to the line.

HOME-BUILT REGULATOR

Figure 2 shows a home-built regulator unit utilizing such a transformer. The circuit is shown in Figure 3. The transformer is a standard filament type with three secondaries of 7.5 volts each. These are connected in *series-aiding* to provide 22.5 volts, and also in series with the primary so that this voltage is added to that of the line. In effect, the unit thus connected is an autotransformer giving a total output of 137.5 volts from a 115-volt line.

The only other essential components are the ballast tube and a standard 4-prong tube socket into which it mounts. As a matter of convenience a standard 2-prong receptacle was also included in the regulator shown and the load plugs into this.

This unit was built to control the supply voltage to a Hallicrafters SX-28 communications receiver when used in a location where the line voltage was abnormally high during the day, and dropped way below its rated value when the lighting load went on at nightfall, only to rise to abnormal levels again when the neighborhood went to bed. Its effectiveness is shown by the figures of Table 1.

In employing a *voltage regulator* of this

type to control the supply to vacuum-tube equipment there is just one precaution to be taken. This is made necessary by the fact that the ballast does not vary its resistance *instantaneously*, nor do vacuum-tube devices draw full current at once. The operating principle of the ballast tubes is based on (1) the rise of temperature of the resistance wire with current flow, and (2) an increase in the resistance of this wire as its temperature increases. Its cold resistance is very low. When the power is turned on it requires a few seconds for the wire to heat and its resistance to rise to the required level. This means that very nearly the full stepped-up voltage will be applied to the load during these few seconds. Then, the load itself may not draw full current at once (in the case of a radio set that does not start drawing plate current until after the filaments have warmed up, for instance). In that case the subnormal load current will result in relatively small drop across the ballast and will continue to allow excessive voltage to be applied to the load until the filaments are completely warmed.

A simple way to overcome both of these difficulties at the same time is to utilize a 3-position switch for the power switch, as shown in Figure 4. Position 1 is the off position. When turned to position 2 the line voltage (without boost) is applied directly to the load. But more than this, the 22.5-volt output of the booster transformer is applied

In order to select the proper ballast for regulating the voltage to any particular load it is necessary to determine the current drawn by that load at its normal 115-120 volt input. Then it is necessary to understand the method of rating standard ballast tubes.

HOW "BALLASTS" ARE RATED

Ballasts are rated according to their effective threshold current, or that which will bring them to the beginning of the flat portion of their current-voltage characteristics, such as the point (A) in Figure 1. Their most effective current range extends upward 10 percent from their rated values and at this higher extreme the voltage drop developed will be at least 200 percent greater than the threshold voltage. There are 12 standard types available, with ratings of 0.2, 0.3, 0.4 and so on up to 1.3 amperes. These ratings are indicated by the type numbers 2A5, 3A5, 4A5, etc.

Now, suppose we have a device which we wish to control and measurement shows that at normal rated line voltage it draws 0.75 amp. The 7A5 ballast is suitable inasmuch as its effective range extends from 0.7 to about 0.77 amp. (threshold rating plus 10 percent). The range of voltage regulation would be somewhat better if the normal load current fell more nearly in the center of this current range but nevertheless will be good. If, on the other hand, the normal load current of the device were 0.7 amp. instead of

last types are better than that indicated by the curve of Figure 1, in that many of them will show voltage drops extending to 40 volts or more before passing current 10 percent in excess of their threshold rating. This is particularly true of ballast designed for use with currents below 0.5 ampere.

These voltage regulator tubes are capable of dissipating 40 watts in continuous service, which means that they are suitable for controlling loads up to 150 watts and higher.

They need not, of course, be employed externally. The components of a unit such as that of Figure 2 could in many cases be included right in the assembly of the device that is to be controlled. Thus where such a combination is included to regulate the voltage to the filaments in a transmitter, the booster transformer and ballast tube could be mounted on the transmitter chassis. In such an application the same regulator could be employed to control the supply to several filament transformers as shown in Figure 5. In this case however, no provision should be made for switching off any of the individual filament circuits separately, because this would result in the application of higher than rated voltage to the filaments left in the circuit.

It should be obvious that, because they are pure resistive devices, these ballast tubes are applicable to both AC and DC circuits. Their only limitation in DC circuits is that there is no means for boosting the supply voltage

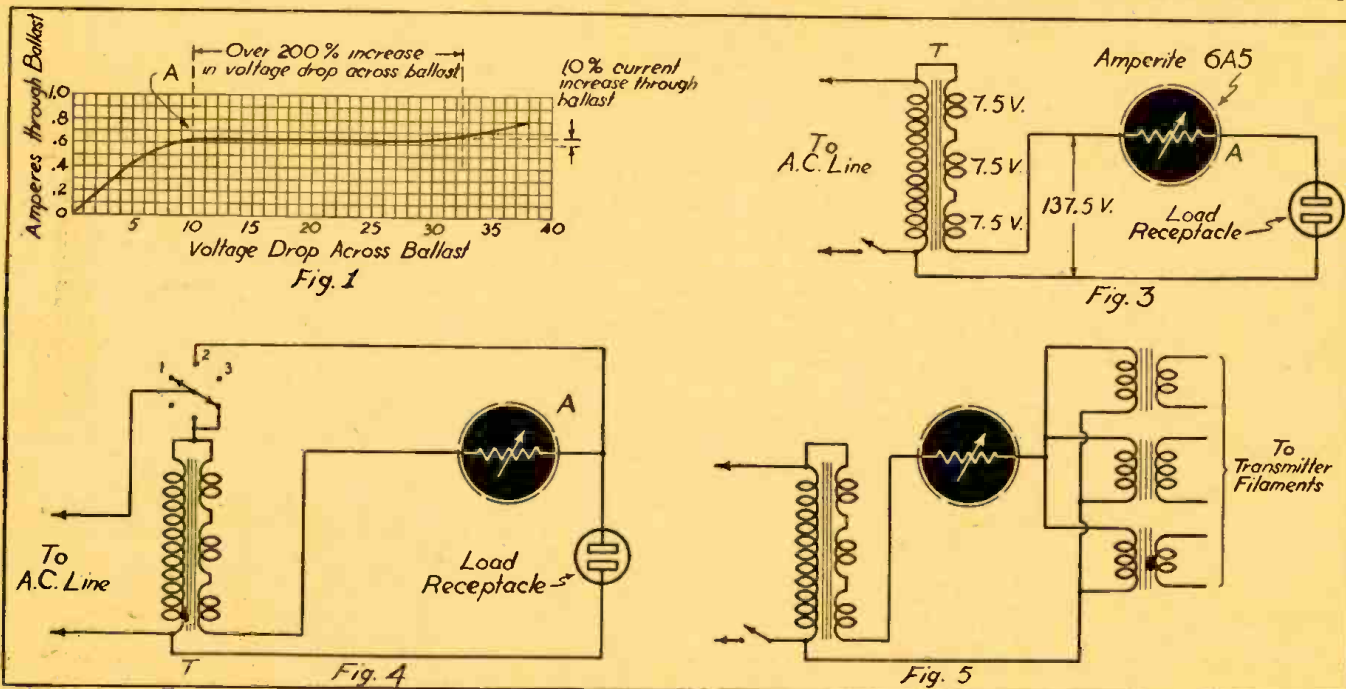

Fig. 1: Control characteristic of a typical ballast regulator tube (Amperite type 6A5). Any tendency toward current change as a result of increasing line voltage causes compensating increase in the voltage drop across the ballast, thus maintaining substantially constant voltage at the load. Fig. 3: Circuit of the unit shown in photos. A filament transformer, with all windings in series, provides the booster voltage. Fig. 4: The circuit of Fig. 3 with 3-position power switch added to prevent application of excessive voltage while ballast and receiver tubes are warming up. Fig. 5: Several "load" circuits can be controlled through a single regulator unit.

directly across the ballast. Thus if the switch is left in this position for 20 seconds or so, the tube filaments will heat up and plate current will start to flow. In the meantime the voltage applied to the ballast will have brought it up to approximately the required operating temperature. Thus when at the end of about 20 seconds the switch is thrown to position 3 both the load and resistor are ready for the application of the higher supply voltage.

The SX-28 receiver draws about 0.85 ampere from the line and the ballast employed in the unit of Figures 2 and 3 is therefore the Amperite type 8A5 (the first number of the type designation indicating that it is for use with loads drawing about 0.8 ampere).

0.75 the regulation would be less satisfactory because downward variations of line voltage would carry the ballast onto the sloping portion of its curve. However, in this case it would be a simple matter to increase the load current slightly by means of a shunt resistor so that the total drain at normal input voltage would be about 0.735 amp. This would bring the load right into the center of the operating range of this ballast, with maximum range of regulation as a result. Likewise if the normal load current were say 0.77 or 0.78 amp. better regulation would be obtained by shunting a resistor across the load to increase the total current to about 0.84, then use a type 8A5 ballast which has an effective current range of 0.8 to 0.88 amp. Actually the effective range of many bal-

to compensate for the drop inherent in the ballast. Where the required load voltage is less than the line voltage, these automatic ballasts make perfect voltage dropping resistors because they not only drop the voltage, but regulate it as well. Two of them can be used in series if necessary to provide large drops.

TABLE I

Line Voltage	Regulated Voltage Applied to Load
105	111
110	113
115	113
120	113
125	114
130	115

BOOK REVIEW

MATHEMATICS—ITS MAGIC AND MASTER. by Aaron Bakst. Published by D. Van Nostrand Company, Inc., Cloth covers, size 5½ x 8¾ ins., 790 pages. Price \$3.95.

This book furnishes a new and interesting way for you to master mathematics by understanding its many valuable and practical everyday uses. It is designed to make mathematics interesting.

Although this book is designed for amusement, it is not restricted to novel, tricky and entertaining mathematical stunts merely. Some interesting subjects treated are systems of numeration, secrecy in numbers, simple calculating devices, problems and puzzles, algebra and its numbers, chain-letter algebra, streamlining everyday computation, Postoffice mathematics, and the grammar of algebra.

In these pages the reader will learn the vital part mathematics plays in every office and shop—in engineering, mechanics, aviation, science, accounting, banking—in the feats of number magicians (which give you many "short-cuts" and "time-savers"), in figuring the best play in games of chance, and in hundreds of other fascinating recreations. All these practical applications of mathematics are fully explained in plain English.

MATHEMATICAL TABLES, by Herbert Bristol Dwight, D.Sc. Published by McGraw-Hill Book Company, Inc., Cloth covers, size 6 x 9¾ ins., 232 pages. Price \$2.50.

Here is a book which any person who has to do mathematical work will find very useful. The arrangement of the tables contained in this book is concise, which leads to great convenience.

In the trigonometric tables in this book, decimals of degrees, to 1/100 degree, are used instead of degrees, minutes and seconds which are in many ways less convenient than decimals. The same advantages of a decimal system are found in these tables, that are experienced in the use of meters and centimeters in place of feet and inches.

In the use of the tables contained in this book, a good number of significant figures are needed, not only in the value of the function but in that of the argument. To obtain the latter, interpolation is used, and this can be done much better if the differences are given. Differences are shown at the right-hand side of practically all the tables in this book.

DRAKE'S CYCLOPEDIA OF RADIO AND ELECTRONICS, Tenth Edition, by Harold P. Manly and L. O. Gorder (1942). Published by Frederick J. Drake & Co. Size 6 x 9 inches, cloth covers. Price \$5.00.

This large volume, profusely illustrated, has the subjects arranged in alphabetical order and will prove most useful to students as well as to the more advanced radiomen.

Many of the diagrams have been specially prepared for this book and they help in a very clear manner to explain the action taking place in vacuum tubes, various radio circuits, etc.

One thing the reviewer likes about this book is that it is very complete and covers such interesting radio topics as aviation radio and landing beams—with very clear explanatory diagrams; storage batteries and their performance; photo cells of various types, with a number of valuable circuits for operating photo-cell relays under different conditions, etc. The inductance of coils and inter-related circuits is nicely covered and the section on filters is very informative.

Other vital subjects covered are loop antennas and their action; measuring instruments and how they work, including vacuum-tube meters; how and why of modulation; public address systems; electric phonographs; short-wave and broadcast receivers—with special treatment of the superheterodyne and how it works.

The final sections of the book deal with resonance, selectivity, shielding, sound, sound pictures, loudspeakers, radio symbols, cathode-ray tubes, television, circuit troubles and how to locate them, various types of special tubes—including the grid-glow tube.

AUTOMATIC RECORD-CHANGERS AND RECORDERS, by John F. Rider. Published by John F. Rider Publisher, Inc. Cloth covers, size 8½ x 11¼ inches, 744 pages. Price \$6.00.

Radio Servicemen will find that this book will give all the general and specific facts about the record-changers and recorders now in the hands of the public. Every Serviceman will find this book very useful during the coming years, as he will have available a reliable source of specific information.

The subject of small electric motors has been dealt with quite extensively in the text section of this book. Also the control of their speed is explained.

Due to the fact that a great many recorders have appeared upon the market lately, and as these devices are so closely allied with automatic record-changers, a description of their mechanism, its functioning and operation has been included, together with data concerning methods

of recording, records, and cutting needles. The same is true of the electric phonograph. A description will be found of the several types of pick-ups and needles, as well as their care and proper operation.

The latter portion of the book is devoted to the manufacturers' service data, which covers practically all the automatic record-changers and recorders on the market at the time the book was written (November 1941).

The book is divided into four chapters, viz.: Chapter I, Motors and Drives; Chapter II, Recorders and Phonographs; Chapter III, Automatic Record-Changers; Chapter IV, Analysis of RCA Model RP-152-C Record-Changer. It is profusely illustrated.

THE RADIO AMATEUR'S HANDBOOK—"Special Defense Edition." Published by The American Radio Relay League, Inc., West Hartford, Conn. Flexible paper covers, size 6½ x 9½ inches. Illustrated.

The well-known Radio Amateur's Handbook has been brought out in a new dress, labeled "Special Defense Edition."

This edition, besides containing the nine basic theoretical chapters included in the standard edition, contains a chapter covering the elementary mathematics necessary for the solution of all formulas and interpretation of graphs appearing throughout the text. This includes a review of decimals, method of extracting square root, algebraic notation and manipulation of formulas, laws of exponents, logarithms, a discussion of linear, power and exponential functions and their application to graphs, and the use of polar coordinates. Supplementing this chapter, a four-place log table is included in the Appendix.

The constructional chapters contained in the regular edition have been condensed into one new chapter. Data on and photographs of the more generally-used commercial receivers and transmitters are included.

Included in this book is a new chapter on learning the radio telegraphic code. Its treatment is based on up-to-date methods of learning by hearing. This can be used either for self-instruction or for the guidance of those interested in giving code classes.

The complete list of chapter headings is as follows: Formulas and Graphs; Electrical and Radio Fundamentals; Vacuum Tubes; Radio-Frequency Power Generation; Radio-telephony; Keying; Receiver Principles and Design; Power Supplies; Wave Propagation; Antenna Systems; Radio Equipment; Measurements and Measuring Equipment; Workshop Practice; Learning the Code; and Appendix (useful formulas, data and charts).

MATHEMATICS FOR RADIO AND COMMUNICATION, by George F. Maedel, A.B., E.E. Published by Maedel Publishing House, Brooklyn, N. Y. Cloth covers, size 9½ x 6 ins. Two volumes: Book I, 314 pages; Book II, 329 pages.

Mr. Maedel is chief instructor at the RCA Institute's Radio School in New York. In order to be a good radio technician today one must have a very thorough background in mathematics and these two books by Mr. Maedel cover the ground thoroughly, and without waste of the readers' time in studying a lot of unrelated mathematics. These two books are official texts on mathematics in the school in which the author teaches.

Book I covers algebra, geometry and arithmetic, while Book II covers advanced algebra, trigonometry and complex numbers. Several interesting chapter titles from the two books on radio mathematics are: Addition, Subtraction, Multiplication and Division in Arithmetic; Definition and Symbols; Factoring; Decimals and Powers of ten; The Metric System; Engineering Problems and the Slide Rule; Solid Geometry; Algebraic Formulas, Logarithms and Decibels; Trigonometric Functions. The Binomial Theorem; etc.

TECHNICAL REVIEW

Hygrade Sylvania recently brought out a tube simplification chart, showing which type of Sylvania tubes may be used to replace various other types of tubes. In some cases one of the new type tubes may be used to replace as many as three different older types of tubes. Every radio Serviceman should have a copy of this tube simplification chart, as it will save him a great amount of time. (Hygrade Sylvania Corp., Emporium, Pa.)

PRACTICAL RADIO INFORMATION

Including Frequency Modulation—Television, etc. Inside Radio Information for all Servicemen—Aircraft Pilots, Students. AUDELS RADIO-MAN'S GUIDE contains 772 Pages, 400 Diagrams & Photos is complete—Fives Authentic Principles & Practices in Construction, Operation, Service & Repairs. Covers clearly and concisely Radio fundamentals—Ohm's Law—Physics of sound as related to radio science—Measuring Instruments—Power supply—Resistors—Inductors—Condensers—Transformers and examples—Broadcasting stations—Radio Telephony—Receivers—Diagrams—Construction—Control systems—Loud speakers—Antenna systems—Auto Radio—Phonograph pickups—Public Address Systems—Aircraft & Marine Radio—Radio Compass—Beacons—Automatic Radio Alarms—Short Wave—Coil Calculations—Testing—Cathode ray oscillographs—Static Elimination—Trouble Finding—Underwriter's standards—Units and tables—Frequency Modulation—REVIEW QUESTIONS & ANSWERS, Ready Reference Index.

\$4 COMPLETE • PAY ONLY \$1 A MO. Get this practical information in handy form for yourself—Fill in and MAIL COUPON TODAY—

AUDEL Publishers, 49 W. 23rd St., N.Y. Mail AUDELS NEW RADIO-MAN'S GUIDE for free examination. If O.K., I will send you \$1 in 7 days; then remit \$1 monthly until \$4 is paid. Otherwise I will return it.

Name _____
Address _____
Occupation _____
Reference _____ RCF

RADIO ENGINEERING DEGREE IN 2½ YEARS

• Complete Radio Engineering Course in 27 months. Bachelor of Science Degree. Radio (television, talking pictures and the vast electronic field) offers unusual opportunities. Defense needs call for the engineer. Demand exceeds the supply. Courses also in Civil, Electrical, Mechanical, Chemical, Aeronautical Engineering; Business Administration, Accounting, Secretarial Science. Tuition, living costs low. World famous for technical 2½ year courses. Special preparatory department for those who lack required high school work. Ent. June, September, January, March, 50th year. Write for catalog. 2452 COLLEGE AVE. ANGOLA, IND.

TRI-STATE COLLEGE

Complete Plans

For Building Useful and Practical Things at Home. Each issue of Popular Homecraft is crammed with plans for making such beautiful and useful things as: Furniture, Bird Houses, Lamps, Outdoor Garden Furniture, Candle Equipment, etc. Covers lathe work, tools, wood-working, leathercraft, copper. You'll find "how" to make almost everything from the pages of Popular Homecraft. Scores of drawings and photographs make every step simple as A B C. A real "How-To-Do-It" magazine.



Six Months' Trial \$1.00
Send \$1.00 today for trial six months' subscription Money Back If Not Delighted.

POPULAR HOMECRAFT

937 Palmolive Building Chicago, Ill.

Trial 6 Months \$1.00

COMMERCIAL RADIO INSTITUTE

A radio training center for over twenty years. Well equipped. Excellent faculty. Practical Resident courses in Radio Telegraphy, Broadcast, Servicing, Industrial, Television, Aeronautical, Drafting, Mathematics and Studio Technique. Placement bureau. Classes now forming. Catalog upon request.

Dept. D, 38 West Biddle Street, Baltimore, Md.

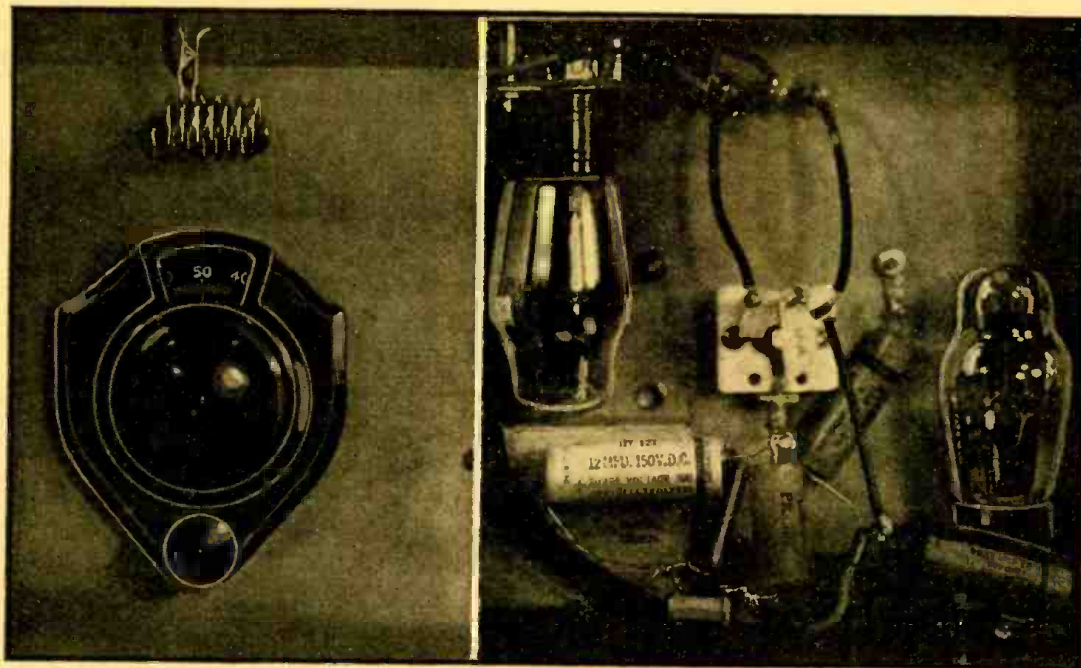

Mr. Baptiste made a very neat job of the U.H.F. Oscillator described in the accompanying article. The oscillator can be built in a short time from parts to be found in your scrap-box.

A Portable U.H.F. OSCILLATOR

GEORGE FRANCIS BAPTISTE

HOW many times have you wished for an ultra high frequency oscillator that was portable and indispensable as well? Here is one that you can build for a few dollars—it can be built in a few hours and prove worthy of the time spent on it. It can be used as a guide for adjusting frequency modulation receivers or amplitude

modulation receivers, and the television bands also. The frequency range with the coil suggested is about 30 to 125 megacycles on fundamentals, or with a small change the same can be adjusted to cover 40 to 150 megacycles. By the use of the harmonic method one can use the instrument to better than 300 megacycles. One

noteworthy feature is that by spreading the coil, one can make a special coil to give wide band pass; this is desirable for adjusting frequency modulation receivers, as well as the television receivers. The oscillator can also be used for television I.F. transformer adjustment, with the correct coil size; this is not difficult for the

The condensers and resistors, together with the two tubes required for the U.H.F. oscillator, are connected as shown in the diagram below.

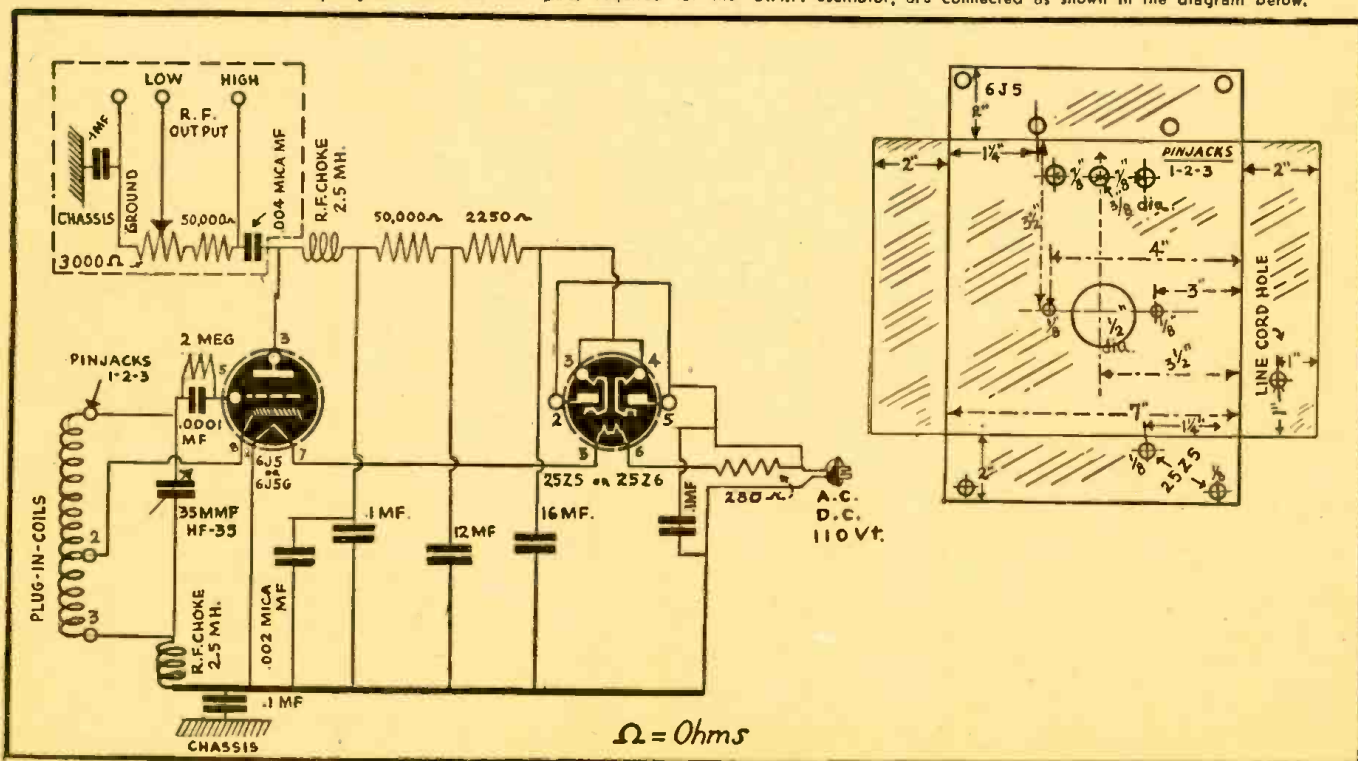

SUPER SPECIALS

average Ham or Radio Bug who likes to experiment with such equipment.

CONSTRUCTION DATA

The complete ultra high frequency oscillator is housed in a small cabinet measuring 7x7x2 inches. Diagram (Fig. 2) gives complete chassis and cabinet layout, which is all on one panel, including the hole drilling dimensions for the complete mounting of all parts.

Diagram (Fig. 1) is the circuit schematic; there are two tubes used, a 6J5G for the oscillator and a 25Z5 as the rectifier. This circuit is the well-known Hartley series-feed oscillator, being a very popular and also a very stable one. The dotted lines on the oscillator diagram indicate an output attenuator network if one is desired. None was used in the original unit as it was found unnecessary, output being sufficient. To couple this output to any receiver under test, all that is necessary is to couple (loosely) a few turns of number 18 or 20 hook-up wire to the oscillator coil and the other end to the receiver under test. In this model the oscillator coil is mounted on the front panel; if one desires it can be mounted inside the cabinet, and a shielded output used.

All coils are wound on a half-inch form, and range from three turns for the highest frequencies up to eight turns for the lower frequencies; coils are cathode tapped about one-third of the total number of turns. A clip is used for this connection so that the tap can be varied to suit one's requirement; also if one wishes to have this oscillator modulated, it can be done by injecting the modulation frequency into the cathode lead, using a blocking condenser for the purpose. This can be for any frequencies one may desire, even to sixty cycles, by loosely coupling, (or directly connecting) the same to the A.C. line with a blocking condenser as stated (or other frequencies of a sine wave form used instead if desired); the injection is done at the 6J5G cathode.

The photos give a general idea of the layout of the parts and tubes; in the rear view it can be seen that the tubes are mounted in opposite corners of the chassis; this position puts one tube upside down, but this does not affect the operation of the oscillator. A 6J5 metal tube may be used if one wishes, or a 25Z6 metal rectifier. The reason being that the tubes were mounted in this position was to reduce the total length of the plate and grid leads, which is important in ultra high frequency work.

Combination phone jacks are used and phone tips are soldered on the ends of the coils; with this arrangement it is possible to plug coils of various sizes in and out at will for the frequencies desired.

An oscillator of this same type was tried for adjusting the R.F. Sections of a frequency modulation receiver, which has a band pass of 150 kc, excellent results were obtained; the oscillator was loosely coupled to the mixer grid, first through a .004 mf. mica condenser and a 400 ohm resistor (sort of a dummy antenna); the condenser and resistor were series-connected. Afterward the oscillator was loosely coupled to the R.F. sections, so that they could also be adjusted. The results were surprising for afterward the standard testing equipment was used to recheck the receiver alignment of the R.F. and mixer stage and it was found to be correctly adjusted.

As a final note it may be well to state that the following size wire may be used, No. 12 or 14 tinned or enamelled copper wire. Do not ground any wire to the chassis, the only chassis ground being the one shown in the schematic, through a .1 mf. blocking condenser. Following is a complete list of
(Continued on page 569)

All of the attractive items listed here are brand new. ALL are in PERFECT WORKING ORDER. In many cases, the parts alone total more than the price we are asking. 100% satisfaction guaranteed or your money refunded.
ORDER FROM THIS PAGE. Use the convenient coupon below. Include sufficient extra remittance for parcel post charges, else order shipped express, collect. Any excess will be refunded. C.O.D. shipments require 20% deposit. If full remittance accompanies order, deduct 2% discount. Send money order, certified check, new U. S. stamps. No C.O.D. to foreign countries.

ORDER TODAY LIMITED QUANTITIES PROMPT SHIPMENTS ASSURED

HANDY WORKSHOP OUTFIT



Here is a marvelous article to the best of our knowledge has never sold at such a low price. This outfit must be seen to be appreciated. It delivers the goods! It comprises a variable speed universal motor for 110 volts A.C. or D.C. Made originally for dictaphone machines by American Gramophone Co. Motor is reconditioned and in excellent condition; all other parts are brand new. Special lever control permits various speeds up to 3000 r.p.m. Measures 7 1/2" x 3 1/4" diam. overall.

Included in the outfit are the following items, as illustrated: 1 excellent chuck which takes drills and other tools—chuck is easily screwed to motor shaft; standard energy wheel, 4" diameter; fine steel rotary saw, 4" diameter; wire scratch brush, 4" diameter; standard cloth buffer, 3" diameter. Total Wt. 9 lbs.

ITEM NO. 149 Complete outfit, including motor. **\$4.95**
Your Price

WESTON MODEL 562 A.C.-D.C. AMMETER

Designed by Weston for the Eastman Kodak Co. It is precision-built magnetic-vane type ammeter which, with suitable shunts, can be used as a milliammeter too. It is 2" in diameter and designed for panel mounting. Bakelite base and black-enamelled cover. Stp. Wt. 2 lbs.



ITEM NO. 35 Your Price **\$1.25**

POWERFUL ALL-PURPOSE INDUCTION MOTOR IDEAL FOR EXPERIMENTERS—101 USES

Sturdily constructed to precision standards, this self-starting shaded pole A.C. induction motor is powerful enough for a large variety of uses. Some of these are: Automatic Timing Devices, Current Interrupters, Electric Fans, Electric Chimes, Window Displays, Photozell Control Devices, Electric Vibrators, Small Grinders, and Polishers. Miniature Pumps, Mechanical Models, Sewing Machines, Phonograph Motors, Coffee Grinders, Motion Picture Projectors, Motorized Valves, Sirens, and other applications.

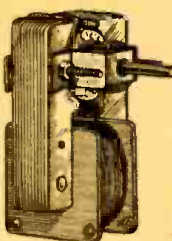

Consumes about 15 watts of power and has a speed of 3,000 r.p.m. When geared down, this sturdy unit will constantly operate an 18-inch turntable loaded with 200 lbs. dead weight—THAT'S POWER!
The motor is of midgeit dimensions, 3 inches high by 2 inches wide by 1 1/2 inches deep; has 4 convenient mounting studs; shaft is 7/8" long by 3/16" diameter, and runs in self-aligning, oil-retaining bearings; the best materials, perfect precision assembly and rigid inspection certify to its high quality, and assure long life. Designed for 110-20 volts, 50-60 cycles, A.C. only.

ITEM NO. 147 **\$1.29**
YOUR PRICE

100 POWER TELESCOPE LENS KIT

Make Your own high powered 6 ft. telescope! Now you can thrill to a closeup view of the worlds out in space. See the rings around Saturn, the mountains of the moon! Kit contains 3" diam., 75" focal length, ground and polished objective lens and 2 astronomical eye-pieces, magnification 50x and 100x. Complete kit with full instructions.

ITEM NO. 123 **\$1.95**
YOUR PRICE

NEW—EXTRA LARGE LENS KIT—contains completely finished 4" diameter 100" focal length ground and polished objective lens, three 1 1/4" diameter eye-pieces giving 66x, 133x, and 200x, an aluminized diagonal for overhead viewing, and a color filter for insertion in any eyepiece.

ITEM NO. 123L **\$3.95**
YOUR PRICE

HUDSON SPECIALTIES CO., 40 West Broadway, N. Y. C.

IT'S EASY TO ORDER—CLIP COUPON—MAIL NOW ORDER FROM THIS PAGE.

HUDSON SPECIALTIES CO., 40 West Broadway, Dept. RC-5/42, New York, N. Y.
I have circled below the numbers of the items I'm ordering. My full remittance of \$..... (include shipping charges) is enclosed.
OR my deposit of \$..... is enclosed (20% required), ship order C.O.D. for balance. No C.O.D. order for less than \$2.00. (New U. S. stamps, check or money order accepted.)
Circle Item No. wanted: 11, 33, 35, 87, 123, 123L, 147, 149, 150, 151
Name Address
City State
Send remittance by check, stamps or money order; register letter if you send cash or stamps.

DISPLAY MOTOR AND TURNTABLE

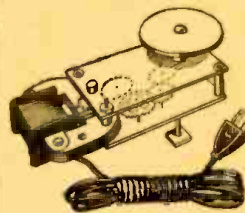

Here is an article ideal for use with a pulley for sliding displays, such as skintin, etc. For horizontal use, it can be used for any type of moving display. Can carry a weight of 20 to 30 lbs.; while with extra ball bearings it will operate under a weight of 50 lbs. Sturdily built motor with five brass gear train, top and bottom pulleys.

Complete with 6-foot cord. Gears are housed between 2 heavy brass plates. Motor operates on A.C. only. Display motor can be used for many other purposes. Self-oiling bearings. Size, overall, 5 1/2" long x 2 3/4" wide x 3" thick.
ITEM NO. 150 **\$2.90**
Your Price

METAL CUTTING SAW

Here is an ideal metal-cutting saw made of fine tool steel specially designed to cut metal. Teeth are set at a special double angle for metal-cutting work. Saw is specially hardened for long and extended use; measures 3 1/4" diameter; center hole is 1/2" square; thickness 42/1000 (42 mils.) 3/8".



Due to the impossibility of securing a new supply, we can sell only those we have on hand. Once these are gone, none are to be had for the duration. Better stock up now with a quantity of these fine saws.
ITEM NO. 151 **50c**
Your Price

VARIABLE SPEED UNIVERSAL MOTOR

FOR 110 VOLTS, A.C. OR D.C.

Made for Dictaphone machines by American Gramophone Co. Used, but in excellent condition. Special lever control permits variable speeds up to 3000 r.p.m. 1/4" shaft extends from both sides of motor. Measures 7 1/2" x 3 1/4" diam. overall. Stp. Wt. 6 1/4 lbs.

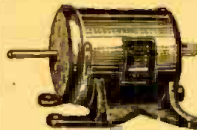

ITEM NO. 21 **\$1.55**
Your Price

AMAZING BLACK LIGHT!!

Powerful 250-watt Ultra-Violet Bulb



The best and most practical source of ultra-violet light for general experimental and entertainment use. Makes all fluorescent substances brilliantly luminescent. No transformers of any kind needed. Fits any standard lamp socket. Made with special filter glass permitting only a tiny ultra-violet ray to come through. Brings out beautiful opalescent hues in various types of materials. Swell for amateur parties, plays, etc., to obtain unique lighting effects. Bulb only. Size of bulb.

Sht. Wt. 1 lb. ITEM NO. 87 **\$2.00**
YOUR PRICE

WESTINGHOUSE WATTHOUR METER

Completely overhauled and ready for immediate service. Designed for regular 110-volt, 60 cycle 2-wire A.C. circuit. Servicemen use it in their shops to check current consumption of sets, soldering irons, etc. Keeps costs down. If dismantled, the parts alone would bring the price. The elaborate gear train could be used as counter on machines of various kinds. Simple to install. 2 wires from the line and 2 wires to the load. Sturdily constructed in heavy metal case. Size: 8 1/2" high, 6 1/4" wide, 5" deep. overall. Stp. Wt. 14 lbs.



ITEM NO. 33 **\$4.50**
Your Price

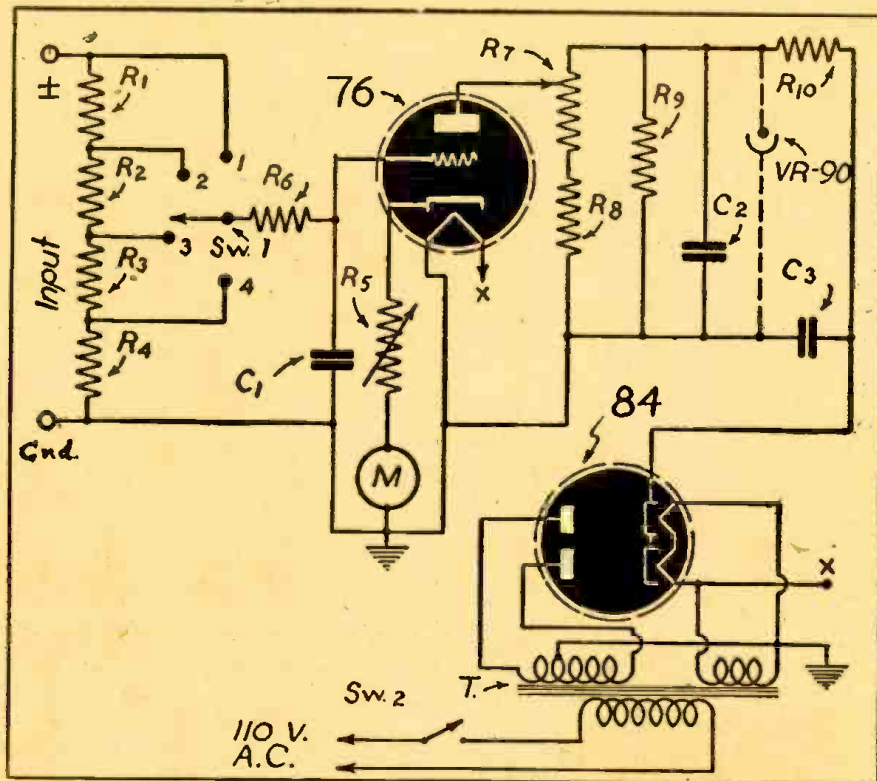

Diagram for the simple D.C. vacuum-tube voltmeter.

A D.C. Vacuum Tube Voltmeter

HARRY S. BIXBY

The radio experimenter as well as the "junior" serviceman will find this instrument very satisfactory for a great many measurements, and its original cost is extremely low.

THE voltmeter described in this article is for use on direct current only. It is a zero-center meter with four ranges: 5-0-5, 25-0-25, 100-0-100, and 500-0-500 volts. The input resistance on all ranges is ten megohms. This is high enough to reduce the error when reading voltage through high-resistance circuits to a minimum, and yet is low enough so that little trouble will be experienced with grid current and false readings as a result.

There are three controls on the front panel: the zero adjust, the range switch, and the on-off switch. No attempt has been made to describe the chassis layout, cabinet, etc., as every serviceman has his own ideas on the subject. The only important thing in regard to the wiring is to use a good grade of hook-up wire and keep the wires from the input, including the switch, well away from the wires carrying current, as leakage will show up readily.

The accuracy of the meter depends on the accuracy of resistors R1, R2, R3, and R4. These should be precision resistors, but these are difficult to obtain here, so I used carbon resistors of the next lower value and filed them down until they were correct.

After the instrument is assembled and wired it must be calibrated. This is done as follows: Adjust bias resistor R5 to approximately 7500 ohms. Set Zero Adjust at extreme counter-clockwise position. Set

Range Switch on 5-0-5 scale. Turn instrument on and allow to warm up. Then set Zero Adjust so meter reads .5 ma. or zero volts. Apply 5 volts D.C. to the input; positive lead going to the ungrounded terminal. The meter should read exactly 1 ma. or 5 volts. If it reads under, turn off power and reduce the value of R5 slightly. Then turn on, allow to warm up, reset Zero Adjust at zero, and apply 5 volts to the input as above. If the reading is high instead of low, increase the value of R5. Always be sure to reset Zero Adjust after changing R5 and before applying the voltage to be checked. Repeat the above adjustments until the meter reads zero volts with no voltage applied, and five volts with five volts applied.

The scale from zero to plus five volts is linear, but the scale from zero to negative five volts is not. After it is calibrated on the positive side, it is suggested that negative voltages from one-half to five volts in one-half volt steps be applied and the readings either be drawn on the meter scale directly, or a chart made showing readings plotted against voltage. Do not change bias resistor after it has been calibrated on positive voltage. If the calibration is carefully made on the 5-0-5 volt scale, it will be accurate on the other ranges.

While a type 76 tube was used in the writer's instrument, a type 37 may be used,

or a 27 or 56 may be utilized if the transformer has a two and one-half volt secondary. In this case probably an 80 would be used as a rectifier.

No voltage control was used, as the line voltage in this section is reasonably steady. However, if one is desired, change the value of R9 to 20,000 ohms and connect a VR-90 as shown by the dotted lines in the schematic.

Will be more than pleased to answer any questions about either the operation or construction of the instrument, if a stamped addressed envelope is enclosed.

LIST OF PARTS

CONDENSERS

- One 600 volt, .02 mf., C1;
- One 450 volt, 8 mf., C2;
- One 600 volt, .1 mf., C3.

RESISTORS

- One 8 megohms, R1;
- One 1.5 megohms, R2;
- One .4 megohm, R3;
- One .1 megohm, R4;
- One 10,000 ohm adjustable, R5;
- One 500,000 ohm 1 watt, R6;
- One 10,000 ohm pot., R7;
- One 10,000 ohm 1 watt, R8;
- One 5,000 ohm 10 watt, R9;
- One 10,000 ohm 10 watt, R10.

MISCELLANEOUS

- One range switch (1, 5-0-5; 2, 25-0-25; 3, 100-0-100; 4, 500-0-500) SW1;
- One AC Switch, SW2;
- One Power Transformer, 6.3 & 700 Vt., c.t., T. (If VR-90 is used change resistor R9 to 20,000 ohms, 1 watt.)

You'll Never Guess This Use for "Pick-ups"!

An American radio manufacturer was recently puzzled when the Du Pont company gave it orders, with a high Government priority, for numbers of sensitive phonograph pickups. Astatic Microphone was still more surprised to find out that Du Pont engineers were putting the phonograph needles not on phonograph records but against factory fences, relaying the

wires' vibrations to amplifiers. So Astatic's engineers redesigned their pickups to make them more compact and weatherproof. Du Pont last fortnight announced the result: fences (equipped with five pickups to the mile) which can catch a wren's song or the sighing wind, and relay the sounds to a watchman five miles away. These pastoral effects, however, are usually filtered

out; what the pickups are after are such contact noises as climbing, tunneling, wire-snipping and other signs of sabotage and trespass. Result: as good a watch in fog, blackout, darkness and storm as could be maintained by guards standing elbow to elbow.—*TIME Magazine*.

If you know of similar new and interesting applications, tell the editors.

SIMPLIFIED "FM" RECEIVER ALIGNMENT

L. M. DEZETTEL

With "FM" receivers in the hands of many thousands of listeners, it is important for the radio Serviceman to understand how to align these new type receivers. We asked Mr. Dezettel, an engineer of wide experience, to tell our readers in simple language how they can proceed to align an average "FM" set. He has prepared the accompanying simplified treatment of the subject for you.

1—FM alignment can be done with but a V-O-M and the station carrier. 2—Small FM adapters, because of their low price, will find their way in great numbers to the serviceman. 3—Home construction kits are recommended for the serviceman who wants to learn the fundamentals of FM.

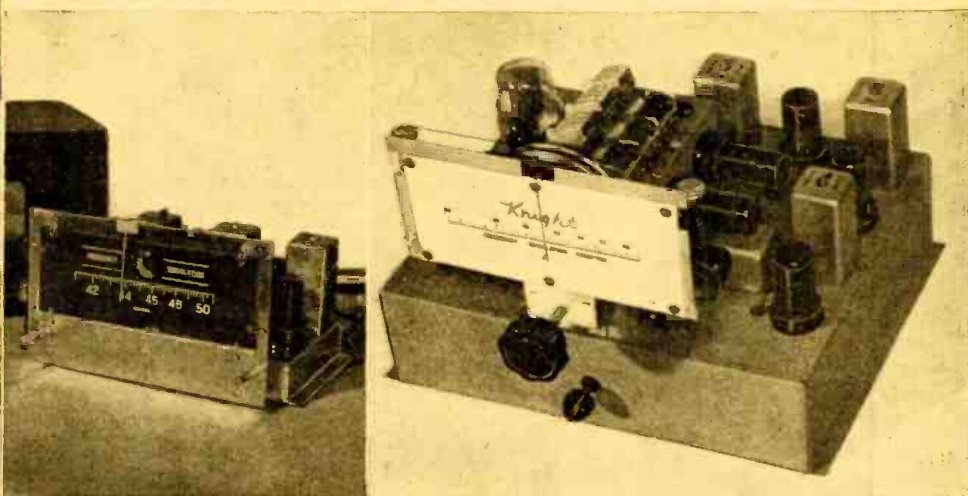

SERVICEMEN who do not possess a million dollars' worth of equipment can still service FM receivers effectively. A good substitute for an FM signal generator is the FM carrier signal from your local FM station. The only equipment required is a 1000 ohm per volt voltmeter and a good alignment screwdriver containing a minimum of metal. A screwdriver made of polystyrene is best. It is important in the alignment of the secondary of the discriminator because this trimmer is not grounded on either side.

Before we tell you about this method of FM receiver alignment, it is necessary to stress the point that a good basic fundamental knowledge of the theory of FM receiver operation is essential. Those of you who are not fully acquainted with the theory behind an FM signal should go over other articles in this and past issues of *Radio-Craft*. The reasonableness of this simplified method of alignment is clear when you know your theory.

Notice that we use the word "alignment" instead of the word "service." The words are somewhat synonymous. Complete servicing includes tracing down open or shorted condensers, open resistors, unwanted oscillation, etc., *plus alignment*. Everything but the alignment is done in the usual manner the same as for AM receivers. FM receivers differ from AM receivers only in the manner of alignment.

No intent is meant here to discredit alignment methods using FM modulated signal generators and cathode ray oscilloscopes. That method is to be preferred if you have the equipment or can afford to buy it. The use of an oscilloscope with an FM signal generator permits you to obtain

a picture of what is going on during the alignment. You can actually see the shape of the I.F. band-width curve and what takes place in the discriminator stage as you adjust it. As desirable as this type of equipment is, and we endorse the purchase of it if you can afford it, it is not essential for the alignment of an FM receiver.

THE FIRST STEP

Now let's get back to our simplified method of alignment. Tune the FM receiver to any one of the FM stations that is on the air and allow the set to warm up for at least 15 minutes. Set your V-O-M on the 100 volt scale or higher, take a polystyrene alignment tool in your hand, and you're all set to go.

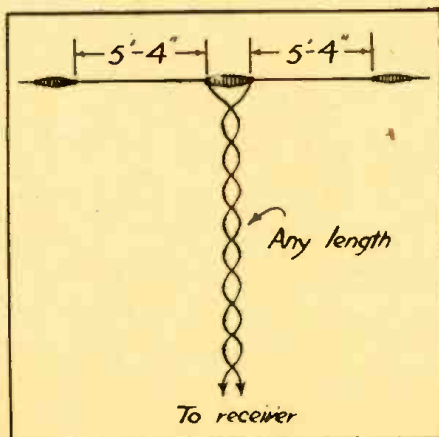

A simple "doublet" antenna of the dimensions shown in the sketch, will help to bring in "FM" stations more efficiently.

Locate the *limiter load resistor*. It may be a single resistor or a series of resistors or a resistor and R.F. sensitivity control potentiometer. At any rate, it will be connected between the ground return connection of the secondary of the third I.F. transformer and the chassis. Connect your voltmeter between that point of the third I.F. transformer and the chassis—the negative terminal to the I.F. transformer and the positive terminal to chassis. Tune the receiver so that maximum signal strength as indicated on the voltmeter is obtained from the FM transmitter. From this point on, the tuning dial must not be touched.

Adjust the trimmers of the first three I.F. transformers for maximum reading on the voltmeter. This is done in exactly the same manner as when aligning an AM receiver.

SECOND STEP

Look for the two discriminator load resistors. You will find two resistors, usually of 100,000 ohms each, connected in series between either the two cathodes of the discriminator tube, or between one of the cathodes of the tube and ground. Transfer the negative terminal of your voltmeter to the mid-point between the two discriminator load resistors. Adjust the primary trimmer of the discriminator transformer for maximum reading on your voltmeter. Now transfer the negative lead of the voltmeter to the "hot" cathode (not the one that is grounded) of the discriminator tube. Adjust the secondary of the discriminator for *Zero* reading on the voltmeter. When we say "adjust for *Zero* reading on the voltmeter," we mean just that—and not a *minus* reading.

\$

IMMEDIATE CASH

for your—

COMMUNICATIONS RECEIVER
TRANSMITTER TEST EQUIPMENT
METERS • PARTS, ETC.

Send us a complete description of your equipment. Mention make, model, age, condition, "improvements," etc. If you have an approximate price in mind, state it. We will make a fair cash offer by return mail.

Hit 'em TWO ways—

- 1—Put your idle apparatus to work, for Victory!
- 2—Buy Victory Bonds with the cash we give you!

Send in your list today!

HARRISON RADIO CO.
12 WEST BROADWAY - NEW YORK CITY

LEARN CODE

the way you'll be using it

by SOUND



The best way to learn to read code is by listening to code. The best way to learn to send code is by hearing your own sending repeated back to you. With the new All-Electric Master

Teleplex Code Teaching Machine, you learn code the natural, easy, fascinating way. Only instrument ever produced which records your sending in visible dots and dashes—then SENDS BACK your own key work at any speed you desire. There are NO PERFORATIONS—NO INK. Far superior to anything ever developed. . . . a marvel of simplicity. That's why practically every school teaching code uses TELEPLEX. We furnish complete course, lend you All-Electric Master Teleplex, give you personal instruction with a MONEY BACK GUARANTEE—all at a surprisingly low cost per month. Write today for FREE catalog \$5. No obligation.

TELEPLEX CO. 107 HUDSON ST. JERSEY CITY, N. J.



QUICK, EASY WAY TO TRAIN FOR RADIO in 8 WEEKS

H. C. Lewis

I'LL FINANCE YOUR TRAINING
Mail the Coupon TODAY and I'll not only tell you about my quick, easy way to train for a good pay job in Radio, Television and Sound, BUT, I'll also tell you how you can get it and pay for it. In Easy monthly payments starting 60 days after 8 weeks' training period.

LEARN BY DOING
On Real Equipment in Coyne Shops
Simple, easy method of Practical Training. You don't need previous experience or a lot of book learning. You work on real equipment in the Coyne Shops at Chicago. This 8 weeks' training prepares you for a job in service and repair work—we also offer radio operating training. Full details of this training will also be sent you when you send coupon.

EARN WHILE LEARNING, Job Help After Graduation
We help you get part time work to help with living expenses and then give you employment service after graduation.

H. C. LEWIS, President,
Radio Division, Coyne Electrical School,
500 S. Paulina St., Dept. 32-8H, Chicago, Ill.
Dear Mr. Lewis:
Please send me your Big FREE Book, and details of your PAY-AFTER-GRADUATION-PLAN.

NAME.....
ADDRESS.....
CITY..... STATE.....

SEND COUPON TODAY

Connect the negative terminal of your voltmeter to the mid-point on the two resistors again and touch up the primary trimmer on the discriminator transformer for maximum reading again. Go back again to a little touching up of the secondary trimmer by the method described above. Each time that one side of a transformer is adjusted, there is a slight change effective on the opposite side, and it is necessary to go back and forth once or twice until no further change occurs.

Let us stress the point again regarding the Zero reading on the voltmeter when the secondary of the discriminator transformer is adjusted. Before you even begin your work the needle on your voltmeter should be set so that it falls exactly on the Zero line when no voltage is applied. When the Zero adjustment mentioned above is made, the needle should fall on the Zero line and not a hair above or below that line.

THIRD STEP

Alignment of the high frequency antenna, R.F. and oscillator circuits is done in the same manner as for AM receivers. That is all there is to the alignment. Checking the accuracy of your work is a simple matter. With the voltmeter connected between the mid-point of the two discriminator load resistors and chassis, tune the FM receiver a few kilocycles above and below its original setting. In one direction the voltmeter will read higher than before and in the other direction, the voltmeter will read lower. The amount higher and lower than the original voltmeter reading should be equal for equal frequency deviations from the original setting of the receiver.

Here is another check. Connect the voltmeter across the entire discriminator load resistor as when adjusting the secondary of the discriminator transformer. Now, when the receiver is tuned above and below the station frequency, the voltmeter should read an equal amount plus and minus from the Zero point. To obtain the reading below the Zero point, it will be necessary for you to reverse the leads from the voltmeter. It will then read above the Zero point but the polarity has been reversed.

Do not worry too much about the extra loading effect of the voltmeter in the discriminator circuit. It is true that the resistance of the meter in parallel with the discriminator load resistors will upset their values somewhat. Fortunately, this change in resistor values does not affect the performance of the FM receiver very much. The ear cannot detect the difference in quality from a received signal, whether the voltmeter is connected in the circuit or not.

It is obvious that a more perfect job can be done if the voltmeter has no loading effect on the circuit. If you are the fortunate possessor of an electronic voltmeter or one of the vacuum tube types, so much the better. As we said before, the ear can't tell the difference.

The adjustment of the discriminator transformer is the most important part of the entire receiver alignment procedure. If this transformer is not tuned properly, musical distortion will result and the background noise level will be higher. If you get a call that an FM receiver is not producing perfectly clear tones, but is distorting, you can bet that the answer in most cases is in the adjustment of discriminator transformer.

Noise reduction takes place in two stages of the FM receiver—the limiter stage and the discriminator stage. Proper peaking of the I.F. channel for the pur-

pose of producing as strong a carrier signal to the limiter stage is important for the reduction of noise. Proper alignment of the discriminator stage allows only the frequency modulated signal to be demodulated into its audio component. Since static, natural or man-made, is mostly amplitude modulated, what little gets to the discriminator stage from the limiter is stopped there if the discriminator transformer is properly aligned.

So you see, that the most important part of servicing FM receivers is in the alignment. With a little intelligence, however, you can do a good job with but simple equipment.

GOOD ANTENNA VERY IMPORTANT

We mention that the limiter stage should receive as strong a signal as possible. Another method by which this is accomplished is the use of a good antenna. While fair performance can be obtained from any kind of a piece of wire used as an antenna, one that is designed for the FM band will give much better results. We are emphatic about the word "much." Don't hesitate to stress the importance of a good antenna to your customer. The installation of the right type of antenna will not only mean more profit to you but will bring your customer amazingly better reception. You can easily build an FM antenna for your customer by following the dimensions shown in the sketch. This antenna is known as a simple doublet or di-pole antenna, familiar to the amateurs who have operated on the ultra high frequency bands. The center insulator should be one of about a 2 or 3 inch length and the triangle formed by the "Y" connection of the feeders should have equal dimensions on the three sides. While any twisted line may be used as lead-in, the better the quality of this lead-in, the better the results. In fact, if a low quality lead-in is used and its length is very great, a point is reached where the losses in the lead-in exceed the benefits of a good antenna. The important point to consider in the quality of lead-in wire is the type of insulation used. Buy the best that your customer can afford.

The ideal lead-in for an FM antenna is a co-axial cable made of copper tubing and ceramic beads for supporting the inner conductor. The next best thing is the flexible type co-axial cable, such as is made by Amphenol, using polystyrene beads.

If all-wave reception is required, you will fare better by purchasing one of the commercially made combination antennas. There are several on the market today. These antennas are cut to a certain length which, with their specially designed transformers, give good efficiency on several bands. Antennas of this type cannot be highly efficient on any one band but are effective compromises where all-band operation is required. We have in mind an excellent antenna of this type made by Taco. This antenna is designed for greatest efficiency on the FM band, where it is needed most.

It is important that the antenna be installed as high as possible and clear of all surrounding buildings or other obstacles. The top element of the antenna must be horizontal as horizontal polarization is now the standard method of FM transmission. The antenna should be installed so that its axis is perpendicular to the line of transmission from the FM broadcast station (i. e., the doublet aerial should be placed broadside to the transmitter).

This article prepared from data supplied by courtesy of the Allied Radio Corp. Mr. Dezettel is an engineer with that company.

INDUSTRY ANSWERS THE CALL!

32,145 Firms With Over
17,700,000 Employees
Have Installed the . . .
PAY-ROLL SAVINGS PLAN

A WAR MESSAGE
to
ALL EMPLOYERS
From the United States Treasury Department

Warfare now is going to take the millions of men, materials and money! An important part of the billions of dollars required to produce the planes, tanks, ships, and guns our Army and Navy need must come from the sale of Defense Bonds. Only by regular pay-day by payroll investment of the American people can this be done.

Facing these facts, your Government needs, urgently, your cooperation with your employees in immediately enrolling them in

A PAY-ROLL SAVINGS PLAN

The voluntary Pay-Roll Savings Plan (approved by organized labor) provides for regular purchases by your employees of Defense Bonds through voluntary payroll allotments. All you do is bill the total funds authorized from payroll allotments in a separate account and deliver a Defense Bond to the employee.

WHAT THE PLAN DOES

1. It provides immediate cash now to equip the Army and Navy for the fight against the Axis. It gives every American wage earner the opportunity to participate in National Defense. 2. By stopping up wages that would otherwise be paid for the purchase of luxuries, it will reduce the current demand for consumer goods while they are scarce, thus preventing inflation. 3. It reduces the percentage of Defense Bonds being purchased on a "one-time" basis. 4. It builds a reserve buying power (or the purchase of bonds) which can be used to keep our factories running after the war. 5. It helps your employees provide for their future.

To get full facts on installing the Pay-Roll Savings Plan, write TODAY to:
Treasury Department, Section C,
709 Twelfth Street, N.W.,
Washington, D. C.

U. S. Defense BONDS * STAMPS

This space contributed to National Defense by
YOUR NAME HERE

10-24100-1 4970



Have YOU Started the Pay-Roll Savings Plan in YOUR Company?

Like a strong, healthy wind, the Pay-Roll Savings Plan is sweeping America! Already more than 32,000 firms, large and small, have adopted the Plan, with a total of over seventeen million employees—and the number is swelling hourly.

But time is short! More and more billions are needed, and needed fast, to help buy the guns, tanks, planes, and ships America's fighting forces must have. The best and quickest way to raise this money is by giving every American wage earner a chance to participate in the regular, systematic purchase of Defense Bonds. The Plan provides the one perfect means of sluicing a part of ALL America's income into the Defense Bond channel regularly every pay-day in an ever-rising flood.

Do your part by installing the Pay-Roll Savings Plan now. For truly, in this war, this people's war, **VICTORY BEGINS AT THE PAY WINDOW.**

Plan Easy to Install

Like all efficient systems, the Pay-Roll Savings Plan is amazingly easy to install, whether your employees number three or ten thousand.

For full facts and samples of free literature, send the coupon below—today! Or write, Treasury Department, Section C, 709 Twelfth Street N.W., Washington, D. C.

MAIL THIS COUPON NOW

Treasury Department, Section C
709-12th St., N.W.
Washington, D. C.

We want to do our part. Please
rush full information regarding
the Pay-Roll Savings Plan.

NAME
POSITION
COMPANY NAME
ADDRESS
NUMBER OF EMPLOYEES



MAKE EVERY PAY-DAY . . . BOND DAY!
U. S. Defense BONDS * STAMPS

• LATEST RADIO APPARATUS •



YOUR ONE DEPENDABLE SOURCE OF SUPPLY . . . Your ALLIED Catalog!

Radio plays a big part in our march to Victory. American radio must stay at top efficiency in the home, in factories, in research labs, in instruction centers. You can help serve on every radio front by depending on ALLIED for Everything in Radio. Your ALLIED Catalog has everything—Radio Receivers; Test Equipment; PA and Intercom Systems to speed up production; 15,000 Parts for service replacement work, for industrial and research application; Tubes, Books, Tools—backed by complete stocks and speedy service. Keep your ALLIED Catalog handy!

SEND FOR YOUR FREE COPY NOW!

ALLIED RADIO CORP.

ALLIED RADIO CORP.
833 W. Jackson Blvd., Dept. 2-E-2
Chicago, Illinois

Send me your FREE 1942 Radio Supply Catalog.

Name

Address

City State

BIG BOY

MODEL 860

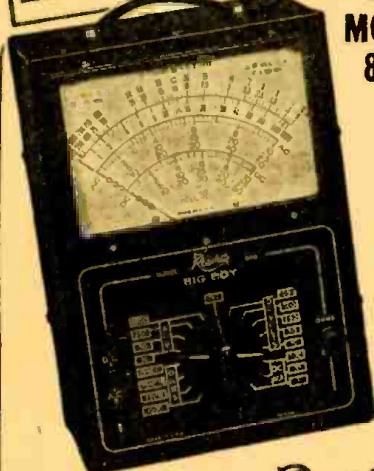

Performance . . . Eye Appeal . . . Value . . . Sensational Priced at \$19.65, Dealer Net Price

Readrite
RANGER

Here is an AC-DC Volt-Ohm-Milliammeter with all the ranges you want . . . easily readable on the large 7" instrument with extra long 67" scale. In a new up-to-the-minute three-tone case. DC Volts 0-10-50-250-500-1000 at 5000 Ohms per volt DC; 1000 ohms per volt AC. AC Volts 0-10-50-250-1000 at 400 ohms per volt; DC Ma. 0-1-10-100; Resistance ranges; 0-1500 Low Ohms; 0-150,000 Ohms and 0-7.5 and 0-15 Megohms. Maroon case with red and silver panel, attached handle.

Dealer Net Price, \$19.65

For Catalog Write—Section 516 College Drive

READRITE METER WORKS, Bluffton, Ohio

Giant-Screen Oscillograph Now Available

● WITH the production and release of several instruments of this latest type, final details are now available regarding the giant Du Mont cathode-ray oscillograph developed for lecture-room demonstration and for more critical laboratory studies.

Known as Type 233, this latest Du Mont oscillograph utilizes the Du Mont 20-inch diameter intensifier-type cathode-ray tube with medium-persistence green screen. The final accelerating potential of 6000 volts provides a high-intensity spot of good resolving power, so that a highly-detailed trace may be observed even in well-illuminated rooms by a large group. The instrument consists of the 20-inch cathode-ray tube; amplifiers for signal deflection along both X- and Y-axes, and for Z-axis or intensity-modulation signals; a linear-time-base generator; and associated power and control circuits.

Newly developed circuits are employed in both the X- and Y-axis signal amplifiers, providing direct coupling from input terminals to deflection plates when such connections are desired, or the more conventional capacitance coupling. The input circuits employ high-impedance compensated stepped attenuators, thermionic impedance transformers, and distortionless continuously-variable amplitude controls. The two-stage amplifiers are phase-inverting and self-balancing, and d.c. positioning is used to provide instantaneous control of spot location. The deflection-signal voltages are balanced above ground and are connected to the deflection plates through jumpers on the rear terminal board, and thus external signal sources can be used for direct deflection if desired.



A linear-time-base generator is available to provide X-axis deflection over a wide frequency range. The time-base voltage, which can be locked to either positive or negative phase of one of several synchronizing signals available, can provide recurrent sweeps for general use or single sweeps for transient studies. Time calibration by means of intensity modulation is provided for by a Z-signal amplifier. Either positive or negative phase of the signal used is available for blanking or intensifying the fluorescent trace.

A beam switch is provided to permit stand-by operation of the oscillograph.

C-D Capacitor Manual for 1942

● A DEFINITE contribution to the government's paper conservation program and to the serviceman's convenience has been made by the novel arrangement adopted for the Cornell-Dubilier Capacitor Manual for 1942. Heretofore it has been the practice to include in this manual each year all the replacement information from previous editions, plus data on new receivers. This year, the new manual takes the form of a supplement with provision for attaching directly to the cover of the 1941 Manual. With no more effort than that required to seal an envelope, the serviceman is thus enabled to convert his 1941 Manual into a 1942 edition so that in a single handy volume he has complete capacitor replacement data on all receivers up to and including current models.

This 50-page supplement adds information on approximately 2000 receiver models, including not only capacitor and voltage values and recommended replacement types, but filter and by-pass circuits employed in each.

High Standards for Communications Equipment

● FEW AMATEURS, short-wave listeners or professional operators stop to realize the extreme precision embodied in the present-day communications receiver. Actually the receivers now used by thousands of private and commercial stations, and coming into use in many homes for direct reception of foreign war news, would have been considered laboratory wonders a few years back.



So close are the tolerances to which these manufacturers work that instruments worth many thousands of dollars are needed in making the final tests to insure that each receiver produced is up to the high standards established for it in the design laboratory. The accompanying illustration shows, for example, just one of the several final-test positions in the Halliercrafters plant—positions at which trained engineers submit every unit to a searching check-up by means of both laboratory measurements and on-the-air operation. In the rare case where an individual receiver (or transmitter) fails to meet the standards, back it goes to the production department to have the trouble corrected.

Bantam Electric Tool

Small Motors, Inc.
1308 Elston Ave., Chicago, Ill.



● THE RADIO experimenter, set-builder and serviceman as well, will find many uses for the electric tool here illustrated. This motor-operated tool is fitted with a chuck to hold drills and small grinding wheels; it operates on 110-115 volts A.C. or D.C. It has very high speed—about 20,000 r.p.m. and has an internal ventilator fan to keep the tool cool. Amateur craftsmen will find this all-around electric tool extremely useful. —Radio-Craft.

40-Watt, 6 V. Battery Amplifier

● A HEAVY duty amplifier with full 40-watt output, which uses no more battery current than most 25-watt units, is now offered by Audio-graph Division of John Meek Industries, Chicago. This unit has built-in power supply for optional 110 v, a-c operation. It is designed for use where large crowds must be covered or where noise conditions require greater power.

A switch provides instant change-over from battery to a-c operation. Special "economizer" switch keeps battery drain low between announcements. Two microphones may be operated simultaneously, with separate volume control for each. Tone control, as well as volume control for phono input, is also included.

This Model BMR-40C amplifier has high gain for any modern high impedance microphone. Frequency response is equal to that of the best a-c amplifiers its sponsors claim. Any number of speakers can be connected at convenient plug-in sockets and terminal board. This amplifier is particularly recommended for use with hand-type mobile microphone for close talking.

New R.C.P. Electronic Multitester

● AN electronically operated, high sensitivity, multi-purpose meter instrument has just been announced by Radio City Products Co., New York City. Known as the RCP "Electronic Multitester," Model 662, it will find wide application in radio and electrical measurement work and is particularly well adapted to the requirements of industrial laboratories and testing departments because of its versatility and negligible loading of circuits under measurement.

This instrument provides a total of 27 measurement ranges to take care of voltages, both a.c. and d.c., up to 6,000 volts; resistance to 1,000 megohms; capacities to 2000 microfarads. The low ranges for each of these types of measurement are such that values as low as 0.1 volt, d.c., 1.0 volt a.c., 0.2 ohms and 30 micro-microfarads (0.000,03 microfarads) can be read directly from the meter scale without interpolation or estimating fractional scale divisions. Any one of the 27 ranges is selected by means of two rotary switches, one of which selects the type of measurement desired, the other the numerical range.



The indicating instrument which is set into the face of the all-metal cabinet, is a 4½ inch square type D'Arsonval microammeter, accurate within 2% of full scale. Its direct-reading scales are laid out on a 100-degree arc. Protection is provided which avoids the possibility of burn-out or other damage to this instrument through improper range selection or attempting measurement of live resistors, etc.

Its vacuum-tube and power supply circuits are built-in and operating power is drawn from any 105-130 volt line.

New Capacitor Hardware

● WHEN IT becomes necessary to replace defective capacitors in some receiver designs, complications are introduced for the service man by special mounting features incorporated in the original capacitor and not duplicated in the stock of replacement capacitors on hand. Here are some new condenser fittings introduced by Cornell-Dubilier.

A cylindrical can type electrolytic that requires replacing may have been mounted by means of a pal nut, spade lugs, projecting tongues with corresponding punched mounting washer, ring or strap. It would be unusual indeed for the service man to have all these various types of replacement units in stock. Moreover, it is more than likely that his jobber would not have them all.



A fact not generally recognized is that there are mounting devices available which make the plainest types of tubular capacitors suitable for replacement of substantially any existing type. These mounting devices take the forms of rings, clips (similar to fuse clips), clamps and straps. Each type is made in a variety of sizes to fit

tubular electrolytic or paper replacement units of various diameters. To apply them requires drilling of two holes in a chassis, at the most. More often they serve to adapt the replacement capacitor for mounting in holes which already exist.

The accompanying photo shows examples of the mounting hardware made available by Cornell-Dubilier for this purpose.

New A.F. Oscillator

● THE JACKSON ELEC. INSTRUMENT CO., Dayton, Ohio, introduce this new Model 652 Audio Frequency Oscillator.

NO ZERO ADJUSTMENT—Tuned Fundamental Frequency method provides permanently locked calibration.

FULL RANGE—20 TO 20,000 CYCLES—Providing more than adequate frequency coverage for all audio analysis requirements.

CONTINUOUSLY VARIABLE—Frequency selection is divided into 3 bands providing instant setting to any desired frequency.

IMPROVED CALIBRATION—No crowding of scales at any frequency. True logarithmic calibration provides constant accuracy of readability throughout the entire range of the instrument. Three (decade) ranges provide over 25 inches of linear calibration—makes possible EXACT settings. For example note ONE CYCLE divisions in range of 20 to 50 cycles on dial.

OUTPUT CHARACTERISTICS—Model 652 meets the most exacting requirements as to wave form—uniform frequency characteristic—and output load impedance selection. A special feature of the output system is the ten ohm tap for low impedance circuits such as speaker voice coils, etc.

COMPLETE STABILITY—Waveform remains constant even to extreme ends of high and low frequency calibration. It is impossible for spurious signals or "beats" to be present in the output.

SIMPLIFIED OPERATION—With Model 652 it is only necessary to select desired FREQUENCY and OUTPUT. There are no other controls. Therefore the possibility of errors in correct operation is eliminated. This feature saves valuable time in using the instrument.



HIGH OUTPUT POWER—More than THREE TIMES the output power usually available from "ordinary" audio oscillators. Ample signal output for any application—even for direct operation of a speaker.

CORRECTION

Several errors occurred in the diagram illustrating the variable frequency audio oscillator on page 496 of the April issue. The list of parts served as a correct guide, but the following incorrect resistor values should be carefully noted. In the upper right-hand corner of the diagram the resistor marked 100 megs. should have read 100,000 ohms and the resistor marked 800 megs. should have read 800,000 ohms. The author also reports that recently he tried a 2,000 ohm unit in place of the 3,500 ohm resistor in the grid circuit of the 12J7GT with superior results.

Likewise the resistor marked 800 megs. in the lower switch group should have read 800,000 ohms and the 100 meg. resistor should be 100,000 ohms. In the right-hand side of the diagram the resistor in the cathode circuit of the 70L7GT should be 500 ohms instead of 500,000 ohms.

SPRAYBERRY RADIO TRAINING
includes
FULL EQUIPMENT
Experience Easily Acquired at Home

You Do Practice-Giving Experiments. Many Special Features . . . ALL Designed to Help You Make Fast Progress

SPRAYBERRY Training starts right at the beginning of Radio . . . unfolds each subject in a simplified, logical, understandable style. You easily learn: Television, Frequency Modulation, Signal Tracing, Mobile Radio (Auto-Tank), Aviation Radio, Electronics, Facsimile Radio, Radio Set Repair and Installation work.

Training Prepares You for a Business of Your Own . . . Or Good Radio Jobs at Excellent Pay

The great fascinating and progressive field of Radio offers many opportunities to the man who wants to get ahead. My Training is designed to give you quick access to these opportunities. SPRAYBERRY Methods are thorough and practical. Your Training will not interfere with your present work. No previous experience is needed.

You Get Professional Test Equipment Plus Complete Radio Set

With the Radio Parts given (everything needed to build a Complete Receiver) . . . you conduct interesting informative experiments with your own hands. Also you are supplied a modern TESTER-ANALYZER.

Earn While You Learn

My BUSINESS BUILDERS show you how to put your equipment to actual use in handling money-making Radio Service jobs shortly after you begin Training.

THE SPRAYBERRY COURSE IS SOLD UNDER MONEY-BACK AGREEMENT

RUSH COUPON for BIG FREE BOOK

SPRAYBERRY ACADEMY OF RADIO
F. L. Sprayberry, President
520-E University Place, N. W.
Washington, D. C.

Please rush my FREE copy of "HOW TO MAKE MONEY IN RADIO."

Name

Address

City

State

(Mail in envelope or paste on penny postcard)

PREPARE YOURSELF

for a commercial radio position through a home study course written for the man who has forgotten higher mathematics and who has had a non-technical education.

This course qualifies you to pass the Federal Radio Telegraph and Telephone examinations.

An easily read, and easily understood course. Moderate tuition fee. Write for particulars.

AMERICAN RADIO INSTITUTE
1123 Broadway New York City

This is YOUR Chance!

No matter what the job is you always get the trained fellow in the best position. This is YOUR CHANCE RIGHT NOW! Radio code operators are wanted by the Army, Navy and in the Commercial Communications fields. Our Merchant Marine wants 40,000 trained radio operators now!

The Candler System has, for over a quarter of a century shown the way to learn code and develop code proficiency at home by their simplified method. Why not write today—there is no obligation, no salesman will call—find out how you too can have a better future.

Get the FREE Book

Drop a post card today for this interesting BOOK OF FACTS which tells you all about the fascinating way to quickly learn code and acquire speed and skill. A copy of this 52-page book is yours—write for it!

CANDLER SYSTEM CO.
Dept. S-5, Box 928, Denver, Colo.

MAKE OLD RADIOS NEW

You can learn quickly to modernize all sets. No more new radios. Cash-in by improving audio circuits, modernizing cabinets, adding features usually found on late model sets. Practical job-sheets with schematics and photographs make the work easy. Complete, 8½ x 11 inches, manual only \$1.00, post-paid. Money back guaranteed.

SUPREME PUBLICATIONS
3727 W. 13th Street, Chicago, Ill.

• LATEST RADIO APPARATUS •

BOOST
Service Profits

**LOWEST PRICES...
 FASTER DELIVERY at
 RADOLEK**

**LARGEST STOCK OF
 EVERYTHING IN RADIO**



Thousands of progressive servicemen rely on Radolek for their complete requirements of repair materials. Radolek has in stock for prompt delivery replacement parts to repair any radio—every type of tube, transformer, speaker, condenser, volume control, resistor, auto radio accessory, etc. Everything you need at lowest prices. You get what you want when you want it—Radolek understands service problems—gets your order to you in double-quick time. Buying from Radolek means Greater Values, Better Service and More Profits. The big new Radolek Radio Service Guide is yours FREE for the asking. Send for your copy today!

**RADOLEK P. A. SYSTEMS
 FOR EVERY REQUIREMENT**



Thousands of successful Radolek P.A. installations are proof of quality, superior design and top performance. Complete systems for permanent, portable or mobile use—wide choice of microphones, speakers and related equipment. Radolek P.A. Systems give you more for your money in Performance, Styling, Dependability and Reserve Power. Select the P.A. apparatus you need from Radolek's big new FREE catalog.

RADOLEK REPAIR SERVICE

Let Radolek repair your damaged or burned out transformers, coils, speakers, test equipment, etc. Many items cannot now be replaced and therefore repairing is the only alternative. Trained craftsmen, using precision tools and factory methods, assure perfect jobs equal to new. Write for prices or better still, send in any article to be repaired. It will be handled promptly.

FREE!



**SEND FOR NEW FREE
 RADIO SERVICE GUIDE**

**RADOLEK CO., Dept. C-66
 601 W. Randolph St., Chicago, Ill.**

Please send the Big FREE Radio Service Guide.

Name

Address

DEALER SERVICEMAN SOUND ENG

SAVE AT RADOLEK

ELECTRONIC AIR RAID SIREN

John Meck Industries, Audiograph Division
 1313 W. Randolph St., Chicago, Ill.

A new electronic type "air raid" siren, designed to give both great volume for alarms as well as a simple method of crowd control, is announced by Audiograph Division of John Meck Industries, Chicago. Called the "Electro-Siren," this unit makes use of a vacuum-tube tone generator which can either duplicate the rising and falling tone of a mechanical siren, or can be set at any pitch for best audibility over traffic or manufacturing noises. It can also be used to send code messages to air raid officials by dots and dashes. Special circuit design allows 50% more power than is possible from an ordinary sound system.

A feature of this new unit is an arrangement so that a microphone can be used for voice announcements over the same system, which takes the place of a public address system. This is important in avoiding confusion and panic in crowded places. A reassuring voice following an air-raid signal may save countless lives.

The electro-siren normally operates from any 110-volt source, but in the case of current failure can be instantly switched to 6 volt storage battery operation. It can also be used in police cars or other vehicles, operating from the car battery.

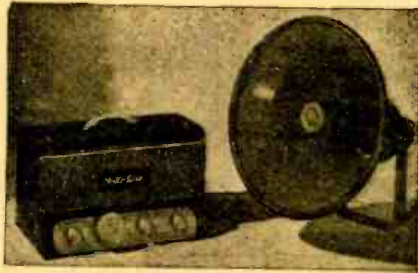

The largest system can be operated continuously for four hours from a fully charged battery.—Radio-Craft.

COMMUNICATING SYSTEM

The Rauland Corp.

4245 No. Knox Ave., Chicago, Ill.

The W-105 is a flexible and useful communicating system for office and industrial application. Warehouses, service stations, small factories, wholesale distributors, professional and business offices will find this system to save much time.

This system consists of a Master, or central control unit, the only amplifier in the entire system. Up to five "remote," or outlying substations can be used. The master or central unit can call and converse with any one of the five remote stations as selected.

A special feature of this system is that the "master" unit can call and "listen-in" or converse with all five remote stations at one time. This is done by means of the sixth, or "all" position on the selector switch.—Radio-Craft.

POLYMET CONDENSERS

Polymet Condenser Company

699 E. 135 St., Bronx, N. Y.

The Polymet Condenser Company has announced a very complete line of high efficiency condensers of all types which they have developed through 21 years of constant research and improvement. The Polymet line includes a long list of electrolytic and by-pass condensers, suitable for replacements in servicing work. A complete list of the various types of condensers this company makes, as well as prices and specifications can be obtained from your local radio dealer, or else by writing direct to the company.

840 Watt Amplifier

● AN 840 watt rack and panel sound amplification unit was recently designed and built by The Rauland Corporation for the new Plum Brook Ordnance plant at Sandusky, Ohio. The equipment comprising that particular installation includes 48 high-powered reproducers and over 16 miles of connecting cable.

The central control unit is capable of sending out all-wave radio programs and phonograph or microphone programs to all of the reproducers and provides audible coverage over an area of more than 80 square miles.

The system is used primarily for instantly locating personnel who might be any point within the limits of the grounds and is instrumental in providing up-to-the-minute broadcasts to all of the employees throughout the plant.

NEW PHONOGRAPH

RCA Mfg. Co., Inc.
 Camden, N. J.

Here's a table-model phonograph with more than ample volume. It is useful for apartments or



homes where space is at a premium, but it will find a place in dormitories, dens, "rumpus rooms," and a score of other locations where music for entertainment or dancing is desired. The instrument is designated as Model R-56. Its motor is self-starting, and the on-off switch and volume control is located handily on the top of the cabinet, serving the dual purpose of a tone arm rest. Either 10- or 12-inch records may be played.—Radio-Craft.

LOW-FREQUENCY LINEAR-TIME-BASE GENERATOR

Allen B. DuMont Labs., Inc.
 2 Main Ave., Passaic, N. J.

For those oscillographic studies requiring sweep frequencies as low as one cycle every few seconds, a Low-Frequency Linear-Time-Base Generator is now announced by Allen B. DuMont Laboratories, Inc., of Passaic, N. J. Used in conjunction with an oscillograph provided with a long persistence cathode-ray tube, or with photographic recording methods, this accessory instrument opens up new fields of investigation of low-frequency transient and recurrent phenomena. Vibration studies stress and strain measurements, low-frequency electrical observation, electrocardiography and electroencephalography, are all facilitated by this new unit. The frequency range of the instrument corresponds to rotating speeds of 12 to 7500 r.p.m., thus permitting the use of an oscillograph for the visual study of certain characteristics of rotating machinery at low and medium speeds. Transient observation is provided for by a single-stroke sweep circuit.

The Type 215 Low-Frequency Linear-Time-Base Generator provides a sweep frequency range of 0.2 to 125 cycles per second. The maximum undistorted output signal is approximately 450 volts peak-to-peak, balanced to ground. The single sweep is initiated either manually or by observed signal. Excellent linearity is assured by a compensating circuit.

Thoroughly portable, the instrument measures 14 3/4" high, 8 13/16" wide, 19 1/4" deep, and weighs 41 lbs. Steel cabinet, black wrinkle finish, with carrying handle. Etched metal black panel. 115 or 230 V. A.C. r.m.s. 40-60 cycle. Power consumption, 50 watts. 1 amp. fuse protection. The primary voltage is selected by a switch in the instrument.—Radio-Craft.

SERVICING BY SIGNAL SUBSTITUTION by G. N. Goldberger, Engineering Division, Precision Apparatus Co. This 120-page book, bound in attractive blue paper covers, contains practical information of interest to radio students and servicemen, in particular. Among the sections noted in this valuable book are—instructions and guide for operation of precision laboratory signal-generator (with diagram of the instrument); the audio test signal and how to use it; how to check tuned R.F. receivers with and without A.V.C.; Super-heterodyne receivers; the adjustment of Frequency Modulation receivers, etc. A closing section deals with the technique of servicing by Signal Substitution, concluding with a chapter entitled "Four Point Rapid Receiver Analysis."

THE SCHOOL SOUND SYSTEM by R. R. Lowdermilk. This book, published by The Federal Radio Education Committee, is interesting to all students of radio and sound applications. It discusses such timely and important topics as Reception of Radio Broadcasts for Classroom Listening; Delayed Radio Broadcast Listening; Administrative Uses; Broadcasting by Students; Problems of Equipment, Design and Arrangement; Provision for the Use of Transcriptions, etc. A valuable section—Part 3—deals with "Student Broadcasting." Here we find some very good discussion on the matter of student announcements, etc.

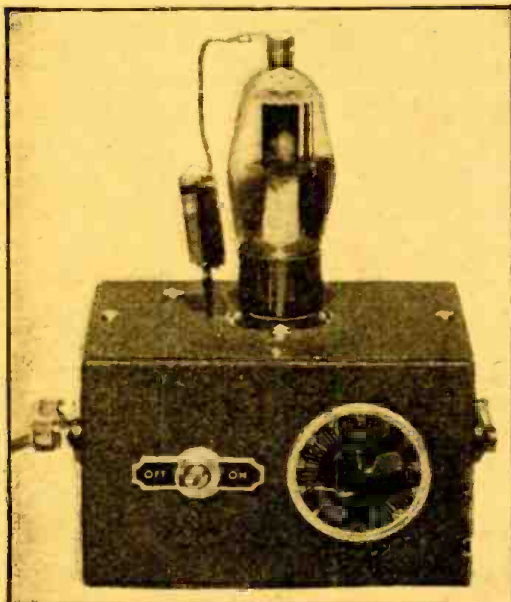

Here is the variable-pitch code oscillator described by Mr. Lee.

An Easy-to-Build A.C. Variable-Pitch CODE OSCILLATOR

This simple one-tube oscillator will be found very efficient and the tone of the note produced by the oscillator may be changed at will. It may be connected with a pair of headphones or a loudspeaker.

J. S. LEE, W8CQP

ALTHOUGH the radio market has been adequately supplied with A.C. operated code practice oscillators for some time, few A.C. outfits of the home-built variety have been described for the would-be radio amateur who desires to own an oscillator and especially one which is not encumbered with batteries. The oscillator to be described has the following worthwhile features:

1. A.C. operation.
2. Variable pitch.
3. Sufficient volume for a small loud-speaker.
4. Inexpensive to build.
5. Neat appearance.

The circuit used incorporates a 12A7 which is a combined pentode and rectifier in one envelope. The rectifier with a simple condenser-resistor filter supplies sufficient direct current to operate the pentode section which is connected as a triode.

The circuit is diagrammed in Fig. 1. Besides the 12A7 tube, the other main piece of apparatus is a midget universal push-pull input transformer of the strap mounted type, that usually sells for about ninety cents. The center-tap connection on the secondary is not used.

The variable pitch feature can be incorporated as desired by the constructor. A five point single pole rotary switch with four small fixed condensers will provide five variations of pitch. Preferences in individual listeners can thus be accommodated. In the original model the high pitch with the switch on the unconnected tap was approximately 1500 cycles per second. The lowest available pitch was about 200 c.p.s.

More than adequate head-phone volume is obtained at the output terminals. A small magnetic speaker or a permanent magnet type dynamic speaker with a matching transformer may be used. This will enable several persons to copy simultaneously.

Mounting the various components in a black crackle case makes a commercial-looking job. However, mounting of the parts on a small board is suitable.

Failure of the circuit to oscillate may be overcome by reversing the secondary leads of the transformer. Correct polarity of the electrolytic filter condensers should also be observed.

The cost of the parts will total about four dollars.

LIST OF PARTS

CONDENSERS

- One 01. mf. paper, 400 volts C_1
- Two 8 mf. electrolytic condensers, 200 volts C_2, C_3
- One .0001 mf. mica C_4
- One .00025 mf. mica C_5
- One .005 mf. paper, 400 volts, C_6
- One .01 mf. paper, 400 volts, C_7

RESISTORS

- One 3 megohms, 1 watt, R_1
- Two 5000 ohms, 1 watt, R_2, R_4
- One 350 ohm line cord resistor, R_3

MISCELLANEOUS

- One 5 point single pole switch with knob and plate, SW
- One Universal midget push-pull input transformer, T

- One 12A7 tube.
- One 3"x4"x5" black crackle can
- One Terminal strip for phones
- One Terminal strip for key
- One Socket, medium 7-prong
- One On-off switch, S

A diagram showing the connections for a loud-speaker is given as Fig. 2. R is a rheostat of approximately thirty ohms which is necessary to provide a load across the speaker output transformer when the circuit is interrupted by the key. The circuit shown provides excellent clean-cut, click-less keying. A "jumper" across the original key terminals is necessary.

Diagram for building the A.C. operated oscillator appears below.

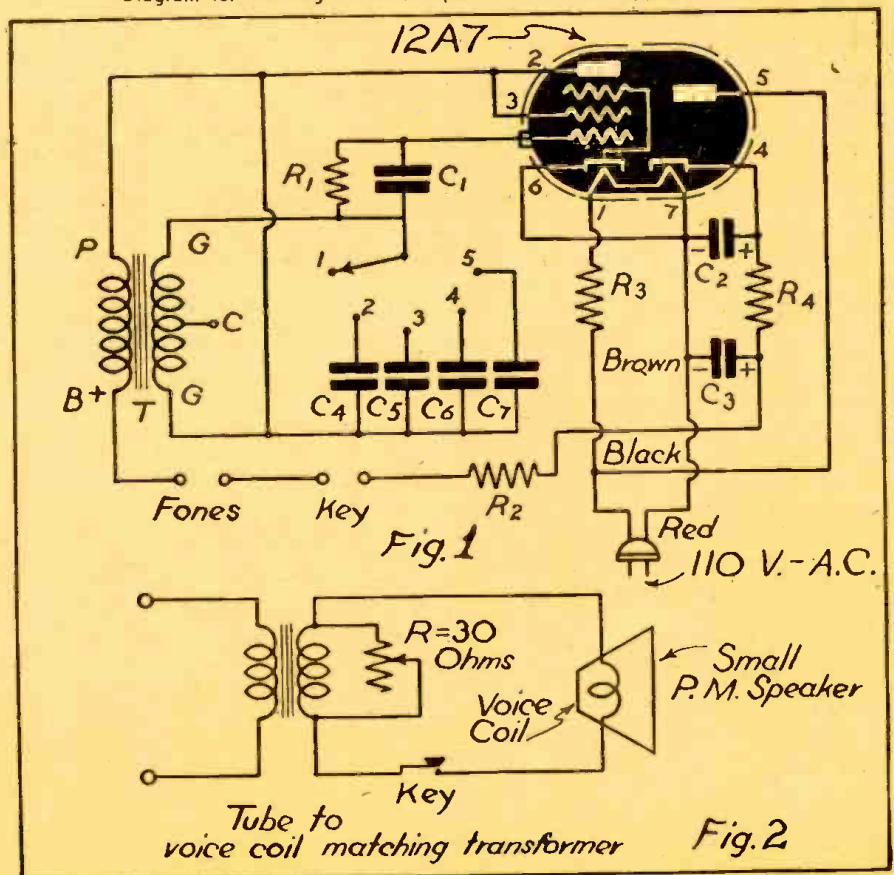

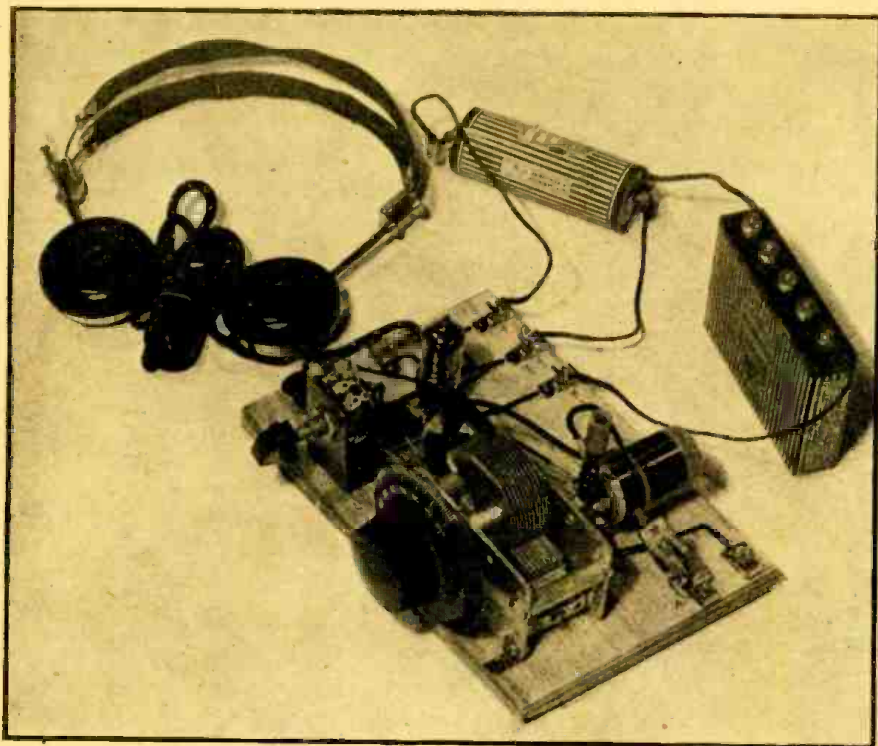

This two-band receiver will appeal by virtue of its simplicity to the radio beginner. It uses a midget-tube, a 1S4, and the set is battery-operated. With a pair of good headphones this makes a dandy portable or "pocket" receiver.

Here is one of the simplest receivers imaginable and "just the ticket" for the radio beginner. It is battery-operated and the cost of the parts is very nominal.

For the Beginner—A 2-BAND MIDGET TUBE Receiver

L. M. DEZETTEL, W9SFW

FOR smoothness of operation and elimination of hum there is nothing like a battery set. The greatest drawback with battery sets is the cost of batteries—the "B" batteries, we mean.

Here is an interesting little set that produces excellent results with earphones and only requires 7½ volts of "B" battery. Fifty-eight cents buys a complete set of batteries, including an oversized 1.5 volt.

Below we see the simple wiring diagram for the one-tube, two-band receiver; the small diagram at the extreme lower right shows coil terminal connections.

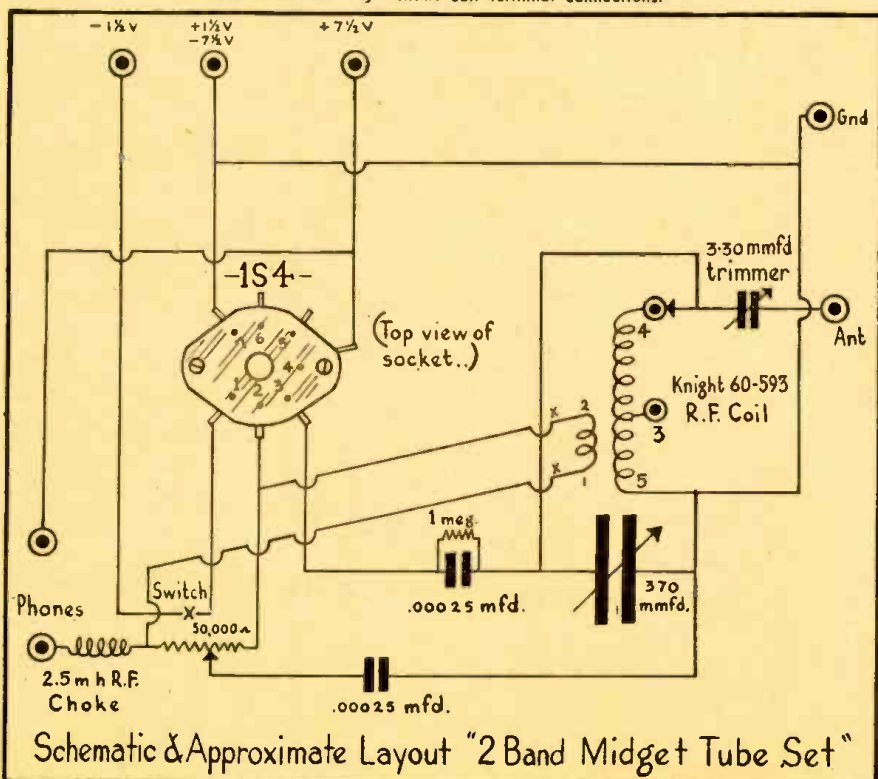

This set uses a 1S4 midget tube in a simple regenerative circuit. It covers the frequencies from 480 kc. to 2.5 mc. in two bands. All parts are standard, of low cost and available at all radio supply houses. An inexpensive tapped R.F. coil (Knight 60-593) was used. This is available in sets of 2 coils only for building TRF sets, but the low price for the set makes it still worthwhile, even though one coil is thrown away. In this application the primary is used as a tickler. A 50,000 ohm regeneration control with a built-on switch makes turning the set on and off more convenient. If you prefer you can use a separate switch or for that matter, no switch at all—merely disconnecting one "A" battery lead to turn the set off.

Actual lay-out of parts is not extremely important for the frequencies this set covers, but it is best to follow the lay-out shown in the photo and diagram. Mount all of the large parts on a 5" x 8" board with No. 6 wood screws. The bracket for mounting the volume control can be purchased ready-made. Use ½" bushings and ⅜" wood screws to mount the tube socket above the base-board. The coil is mounted by its mounting bracket to the variable condenser. A ½" bushing is used here, too. The battery, phones and antenna and ground connectors are Fahnestock

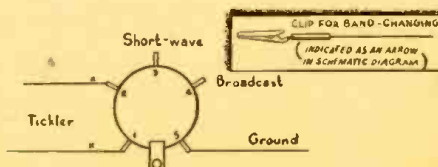

Coil Terminal Connections

spring clips. The band-switching is accomplished by means of an alligator clip, which is merely clipped to the proper terminal of the coil for band-changing.

Good connection to the Fahnestock clips can be made by merely wrapping the hook-up wire one turn under the screw head. All other connections should be securely soldered. Connecting leads should not be excessive in length. The points marked X are the terminals of the tickler winding on the coil. It may be necessary to reverse the connections at these points to obtain oscillation.

Successful operation will depend a great deal on the quality of the ground and antenna. The ground should be a good connection to a cold water pipe or to a 6 ft. rod driven into moist earth. The antenna should be about 100 ft. long and as high as possible. It should be clear of trees and surrounding buildings and well insulated.

With the set wired and batteries, phones, antenna and ground connected, you are ready to try it. The antenna trimmer condenser should be at maximum capacity (screw turned in tight). Set the regeneration control half way on, and the alligator clip on the broadcast band terminal of the coil. As you rotate the main tuning condenser you will hear several squeals, indicating the presence of station signals. Turn the regeneration control slowly to the left—at the same time retuning the condenser. A point will be found where the oscillations cease and the stations will be heard loud and clear. The same procedure should be followed for tuning on the high-frequency band, except that it must be done more slowly. In case it is not possible to maintain oscillation, reduce the capacity of the trimmer condenser. Adjusting the tickler coil up and down on the secondary also helps in obtaining smoother oscillation. Once the proper position of the tickler winding is found, it may be cemented in position.

This article prepared from data supplied through the courtesy of Allied Radio Corporation.

LIST OF PARTS

- 1—3.30 mmf. trimmer condenser
- 1—370 mmf. tuning condenser
- 2—.00025 mfd. mica condensers
- 1—50,000 ohm potentiometer with switch
- 1—1 megohm 1/4 watt resistor
- 1—2.5 mh-RF choke
- 1—Knight 60-593 coil
- 1—Knight 1S4 tube
- 1—Miniature tube wafer socket
- 1—Alligator clip
- 7—Fahnestock clips
- 1—3" tuning dial
- 1—1/4" pointer knob
- 1—Metal bracket for potentiometer (Knight 43-620)
- 1—1 1/2 volt "A" battery
- 1—7 1/2 volt "C" battery (used for "B")
- 1—Pair headphones
- Miscellaneous wire and hardware

BEGINNERS' ARTICLES

WANTED. Come on authors and embryo authors! Send along your pet idea or description of a set which you think will interest the Radio Beginner. Receivers, Converters, Photo-Electric apparatus, Experimental Electrical apparatus, Sound Reproducers (Record Players), etc.

Address all manuscripts to the Editor, Radio-Craft Magazine, 25 West Broadway, New York, N. Y.

FREE!

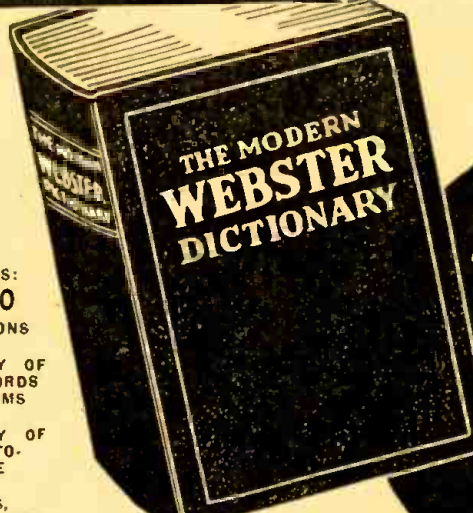

CONTAINS:
22,000 DEFINITIONS
DICTIONARY OF RADIO WORDS AND TERMS
DICTIONARY OF THE AUTO-MOBILE
TABLES, TREATISES, ETC.

FLEXIBLE IMITATION LEATHERETTE COVER. SIZE 5 1/2"x8"

with \$1.00 subscription to RADIO-CRAFT

FULL LIBRARY SIZE MODERN WEBSTER DICTIONARY 416 PAGES

If you will take advantage NOW of our special subscription offer of eight months for \$1.00, we will send you ABSOLUTELY FREE and POST-PAID this 416 page full library size MODERN WEBSTER DICTIONARY—useful and instructive to everyone. This self-pronouncing authoritative dictionary—a new work throughout—contains the most up-to-date words now in common use, 22,000 definitions in all. It also features a Glossary of Radio Words and Terms, Dictionary of the Automobile, Treatises on Practical Syntax, Etymology, Punctuation and Standard English by well known authorities, Metric Tables, Time, State Flowers, National Parks of the U. S., etc.

This is a time limited offer, so don't delay in returning the Coupon.

RADIO-CRAFT

25 WEST BROADWAY NEW YORK CITY

FILL OUT—MAIL THIS COUPON TODAY!

RADIO-CRAFT, 25 West Broadway, New York, N. Y.
 This is a New Order Extend my present subscription
 Gentlemen: Enclosed you will find One Dollar for which enter my subscription to RADIO-CRAFT Magazine for Eight Months. Send me ABSOLUTELY FREE and POST-PAID, my copy of the MODERN WEBSTER DICTIONARY.
 Name
 Address
 City State
 (Remit by check or money order; register letter if you send cash or unused U.S. Postage Stamps) RC-5-42

SPECIAL

ABC OF TELEVISION
 Contains latest material on Television developments. It covers theory of scanning; simple television receiver; how the eye sees; the photo-electric cell; neop lamps; need for broad channel width in transmission of high-fidelity television signals; cathode ray tube and television receivers; Farnsworth system of television transmission; and other important features.

SHORT WAVE GUIDE
 Covers hundreds of short-wave questions and answers; illustrates popular short-wave links; gives explicit instructions for building simple short-wave receivers; instruction on the best type of antenna installation; diagram and construction details for building transmitters.

The books listed below have never been sold by us before. The value of each book is 50c. They are exactly the same as RADIO & TELEVISION'S 50c blue books which have been on the market for years. For a short time only we are selling these at a special reduced price of only 75c for the 3 books. All of the books contain numerous photographic illustrations and diagrams and have stiff flexible cover.

S. W. RADIO QUIZ BOOK
 This book covers questions and answers on transmitters, ultra short-wave receivers, practical winding data; novel hook-ups for experimenters; how to "hook-up" converters, noise silencers, power supplies, modulators, pro-oscillators, antennas, selector, 5-meter receivers.

Popular Book Corp., 25 W. Broadway, New York, N. Y.
 Gentlemen: Enclosed you will find remittance for 75c (cash, new U. S. stamps or money order accepted) for which please send me at once your 3 books ABC OF TELEVISION SHORT WAVE GUIDE S. W. RADIO QUIZ BOOK
 Name
 Address
 City State RC-5-42

HIGH VOLTAGE!

Officials of the British Supply Council disclose an unrecorded incident of Winston Churchill's visit to Canada.

There is a deep plush rug in Government House, Ottawa, famous for generating static electricity in the human body. Sparks are sometimes visible when two persons shake hands. The phenomenon fascinated the Prime Minister. While an officer was explaining that the

sparks were partly due to Canada's cold, dry climate, the young wife of a government official trotted up and introduced herself. As they shook hands, the Prime Minister felt a sharp shock. Wheeling, he asked the officer:

"I say, doesn't this sort of thing make courting rather difficult in Canada?"—New York Daily Mirror.

TALKING ON A LIGHT BEAM

A number of interesting experiments are made possible with the apparatus described by Mr. Solms for the transmission and reception by means of a light beam. This means of communication is particularly interesting at this time, as it does not require a license for its operation and it represents a novel experiment in science.

JAMES SOLMS

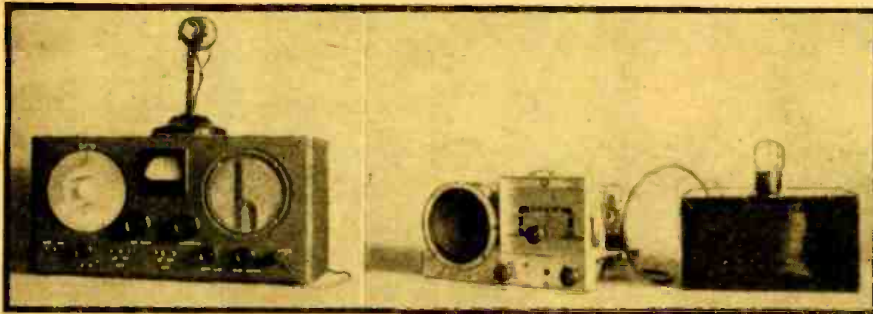

Photo at the left shows microphone and receiver used as a modulator for light beam transmission experiments. Photo at right shows photo-cell and receiver.

must be used to connect the box to the amplifier. The shielding, used as one conductor between the photo-cell and amplifier, is grounded to the box and to the amplifier chassis.

If a special amplifier is not available, a fairly modern receiver may be used instead. The receiver must have at least one stage of pentode amplification preceding the power output tube. Figure 5 shows how to connect the photo-cell receiver to the detector of a t.r.f. or superhet receiver. If the receiver has a separate phono input, the photo-cell apparatus may be connected to it directly. Figure 4 shows an amplifier which can be used for this application and which can be built at low cost.

After the photo-cell receiver has been connected to the amplifier, a loud hum will be produced if light from a lamp connected to an A.C. source is allowed to fall upon the cell. Thumps are heard from the loud speaker when a flashlight beam is swung across the cell. If these effects are produced, the receiver is working correctly.

The reflected beam from the vibrating mirror should now be directed at the cell. The volume control at the transmitter amplifier should be kept at a low level since very little power is required to vibrate the mirror. The greater the distance between the transmitter and receiver, the less will be the modulator power required since at a greater distance the beam will sweep over

THE purpose of the apparatus to be described is the transmission of sound by means of a modulated light beam.

Equipment of this sort may be used for various practical purposes, but the apparatus here described was developed for experimental purposes only.

Here is how the equipment works: A beam of light is deflected from side to side by means of a vibrating mirror mechanism with an amplitude proportional to the amplitude of the transmitted voice or music impulses, and at a speed determined by the frequency of these impulses. The mechanism which causes the mirror to vibrate is connected to an audio amplifier which supplies the power necessary to accomplish this. The light beam, having been modulated, is directed upon a photo-electric cell. Minute electric currents developed by the cell, varying in accordance with the modulation of the light beam, are amplified by amplifying equipment of suitable sensitivity and converted into sound by means of a loud speaker.

Direct sunlight is used as a light source in the experiments. A mirror mounted in a window sill can easily be adjusted to direct light onto the vibrating mirror.

An artificial source of light may also be used. Special light sources, intended for use with photocell equipment, are available from various manufacturers. Direct current must be used for an artificial light source if hum is to be avoided.

An old magnetic loudspeaker is used to make the mirror vibrate. The diaphragm of the magnetic speaker is removed and the speaker is stripped of all unnecessary parts. The connecting rod which transmits vibrations from the speaker coil to the diaphragm should not be damaged. A small chip of mirror about 1/2 in. square should be fastened to the end of the moving rod by a drop of sealing wax.

The author used his Sky Buddy receiver as a source of power for the magnetic speaker. In this case the speaker coil was connected to the headphone jack of the receiver. Figure 2 shows a method of connecting the output of a receiver to the vibrator. Regular broadcast programs may be used

when adjusting the apparatus. If voice transmission is desired, a microphone may be attached to the receiver if the receiver is of suitable design. A wireless phonograph oscillator having provision for a microphone may be used in conjunction with the receiver with good results.

The photo-cell receiver circuit is shown in Fig. 3. A pair of 45-volt "B" batteries are used for the anode voltage of the cell. The batteries and the 3:1 audio transformer must be mounted in a shielding container to avoid hum pickup. An old cookie tin given a coat of black enamel serves well for this purpose. The photo-electric cell is plugged into a four prong tube socket mounted on the top of the metal box. A two foot length of shielded microphone cable

This diagram shows voice modulator made with a vibrating mirror and a modulator, together with photo-cell receiver.

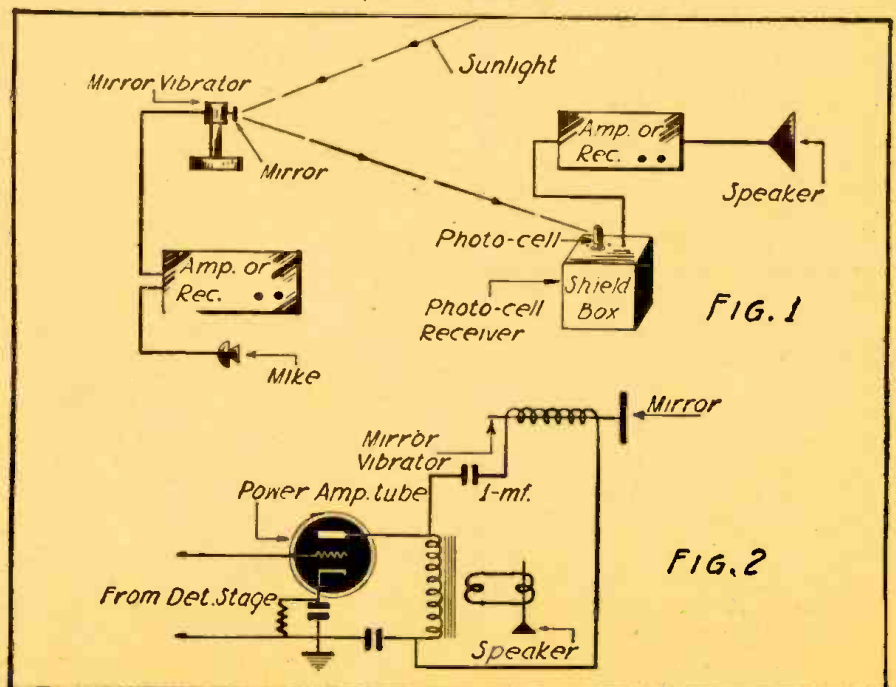

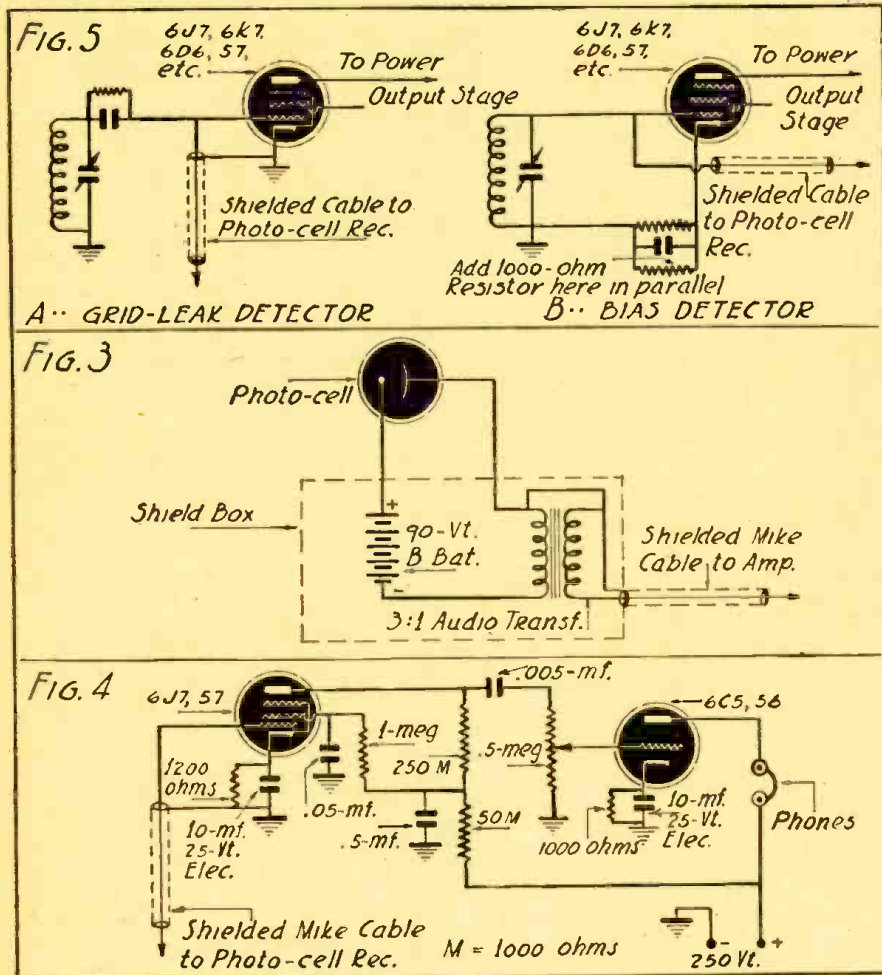

Fig. 5 shows two forms of detector for use with the photo-cell; Fig. 3 shows photo-cell amplifier circuit for use with headphones.

a wider arc. It will usually be necessary to advance the photo-cell receiver volume control to the maximum to provide adequate amplification.

ENEMY CAN'T LOCATE FM STATIONS!

Citing a number of obstacles which FM's inherent vigor had already overcome, Mr. McCanne, assistant general manager of the Stromberg-Carlson Tel. Mfg. Co., told an audience recently that FM was moving now at even more rapid a pace than had been anticipated. Until now, FM had been sold only on its tonal qualities; perhaps its more important advantage, the wiping out of station interference, has remained virtually a mystery to the public. In the future, he said FM would draw a huge audience with this factor alone.

Mr. McCanne told his audience of engineers that FM might draw additional benefit from its usefulness as a "blackout" broadcasting system, since in the opinion of authorities a loop (antenna) could not be focussed on the transmitter and the source of FM broadcasts exactly located by engineers the belief had been expressed by authorities that bombers seeking to locate the source of FM broadcasts could fly over its entire authorized broadcast area, without being aware of its transmitter location.

A Call To Service Men!

The Editors would like to hear from radio men in the service as to what kind of articles they would like to see in RADIO-CRAFT.

Do you want more articles on "how and why"—including the mathematics, of frequency modulation?

Or do you want more Elementary Electricity articles with electrical hints, circuits and constructional data?

Or do you want more articles on Antennas, Ultra Short Waves, etc.?

Let's hear from you and we will endeavor to publish what you most need. A post-card will do. Write to the Editor, RADIO-CRAFT, 25 W. Broadway, New York City.

DISPOSAL SALE
OF RECONDITIONED
AMPLIFIERS & PARTS

IN GUARANTEED PERFECT MECHANICAL AND ELECTRICAL CONDITION

Photo shows 30 watt ampl. # 104A



All ampl. shipped Ready to operate

#102—12 WATT PUSH-PULL 2A3 AMPLIFIER
To be used with one or two 2500 ohm dynamic speakers 16 ohm voice coil. May be changed over to use P.M. speakers. Input for magnetic pickup. Variable tone control. Schematic furnished to change unit over to use crystal pickup, crystal microphone and P.M. speakers. **\$8.75**

#102A—12 WATT PUSH-PULL 2A3 AMPLIFIER
Frequency response plus or minus 2DB. from 30 to 15,000 CPS. bass and treble boost. Inputs for phono pick-up or radio tuner. Output impedance 8 or 16 ohms to P.M. or Electro-Dynamic speakers, supplies field current for one or two 2500 ohm speaker fields. An excellent amplifier for FM or recording. **\$18.45**

Set of Matched Tubes for either #102 or #102A, 1-57, 1-56, 2-2A3, 1-5Z3 **\$1.73**

Shipping Weight 25 lbs. for either of above

#103—20 WATT PUSH-PULL 6L6 AMPLIFIER
To be used with one or two 2500 ohm dynamic speakers 16 ohm voice coil. May be changed over to use P.M. speakers. Input for magnetic pickup. Variable tone control. Schematic furnished to change unit over to use crystal pickup, crystal microphone and P.M. speakers. **\$9.85**

Set of Matched Tubes: 2-6L6, 1-6A6, 1-76, 1-5Z3 **\$1.78**

#103A—20 WATT PUSH-PULL 6L6 AMPLIFIER
Input for one crystal or dynamic microphone. Input for one crystal or magnetic phono pick-up. Full range tone control. Frequency response 30 to 10,000 CPS. Output impedance 8 or 16 ohms to FM or Electric-Dynamic speakers, supplies field current for one or two 2500 ohm speaker fields. **\$15.95**

Set of Matched Tubes: 1-6SF5, 1-76, 1-6A6, 2-6L6, 1-5Z3 **\$2.29**

Shipping Weight 24 lbs. for either of above

#104—30 WATT PUSH-PULL 6L6 AMPLIFIER
Has input for magnetic pickup, volume control, variable tone control. Supplies field current to one or two 2500 ohm dynamic speakers, output impedance 2.6, 3.2, 4, 5.3, 8, and 16 ohms. Full 30 watts output. Schematic furnished to change unit over to use crystal pickup and crystal, dynamic or velocity microphone and change over to use P.M. speakers. **\$12.05**

Set of Matched Tubes: 1-6C6, 1-6A6, 2-6L6, 1-5Z3, **\$1.78**

#104A—30 WATT PUSH-PULL 6L6 AMPLIFIER
Input for two crystal, dynamic or velocity microphones individually controlled. Input for crystal or high impedance phono pick-up. Full range tone control. Frequency response 30 to 10,000 CPS. Output impedance 2.6, 3.2, 4, 5.3, 8 and 16 ohms to P.M. or Electro-Dynamic speakers, supplies field current for one or two 2500 ohm speaker fields. **\$21.45**

Set of Matched Tubes: 2-6SF5, 1-6C6, 1-6A6, 2-6L6, 1-5Z3, **\$2.80**

Shipping Weight 26 lbs. for either of above

All Amplifiers Less Tubes & Speakers.



JENSEN 10 INCH
ELECTRO-DYNAMIC
SPEAKER
2500 OHM FIELD
16 OHM VOICE-COIL

EACH **\$2.95**
Shipping Weight 7 lbs.

ORDERS SHIPPED SAME DAY AS RECEIVED. All goods are sent Express collect if no money for Parcel Post is included in remittance. Customers in Foreign countries are requested to remit in U. S. Currency or International Money Orders and include enough money to ship goods prepaid. Order from this ad.

25% deposit required on all C.O.D. orders.
PEERLESS RADIO
AND SOUND CORP.
25 S. JEFFERSON ST., Dept. 542 CHICAGO, ILL.

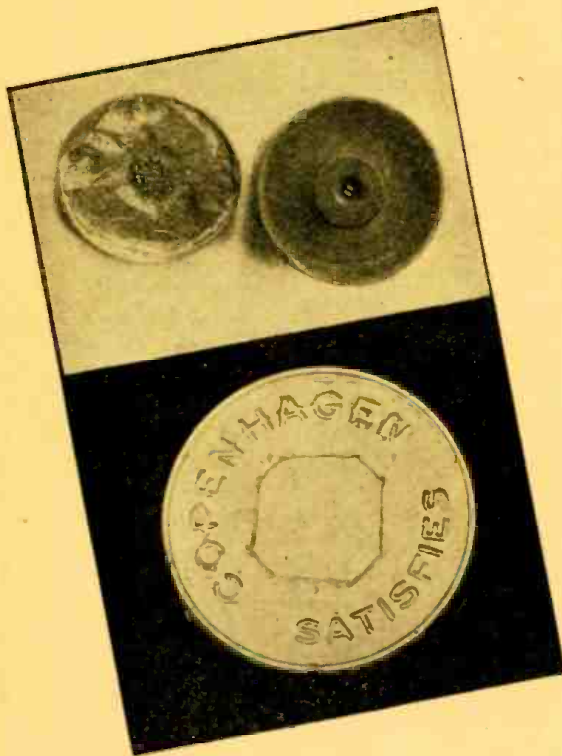

Experimental "Chew-Box" MIKE

Electrical and radio experimenters often require a simple carbon-grain microphone; the author describes how to make such a mike from simple parts to be found in every experimenter's lab.

HOMER L. DAVIDSON

Top photo at left shows carbon grains, tinfoil diaphragm, and felt washer. Lower photo shows appearance of the mike from the front.

WITH a Copenhagen chewing tobacco box and a few tools a beginner can build this carbon "chew-box" mike within one hour. This chew-box mike was made as an experimental venture and results were found to be satisfactory under certain conditions.

We took an old chewing tobacco can, although any tobacco or snuff box will do, and then chiseled out a hole in the tin lid. Looking around we found a small diameter, thick felt washer and drilled a small hole down into it about one-half inch in diameter, then drilled a smaller one one-eighth inch hole clear through the felt washer. Through the felt washer we placed an 8-32 by 1 1/4 inch machine screw, with metal washers on both sides, screwing the washers tight against the felt washer.

Then the felt washer was mounted through a hole in the back of the tobacco container, which is made of cardboard. Push this felt washer up until it is even with the top of the can. A few changes may be necessary to obtain the correct adjustment.

Next we cut a piece of tinfoil just about

one quarter of an inch larger than the tin lid, so that when the cap was placed on the box the foil would stretch. One can also experiment with a light piece of metal if he so desires. Any flexible cord will serve to connect the mike lead to the tin lid.

In our first experiment we tried using

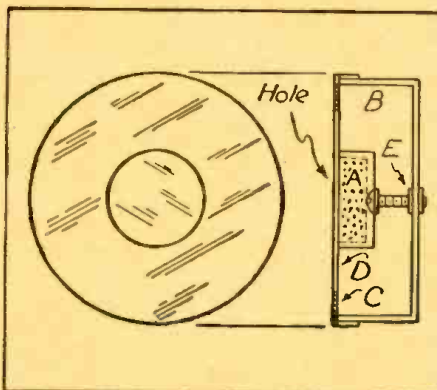

Sectional diagram of the microphone.

crushed carbon obtained from an old flash-light cell and it worked surprisingly well, although polished carbon granules proved 100% better. So if you do not have any granules handy, you can experiment with flash-light rods or take an old pencil, remove the lead and scrape it with a knife. Do not get the cup too full, because this will make the mike pack (dead)! It seemed to give a better tone and quality when about three-quarters full.

After completing the "chew-box" mike it is best to test its sensitivity with an ohmmeter, if one is handy. By placing your ohmmeter leads on to the two mike leads, we now have a complete circuit, in which the ohmmeter contains an e.m.f. in series with meter and mike. Blow upon the chew-box mike and if the needle flicks over, it is ready for a voice test.

If you connect the mike to the grid of the first audio stage of your B.C. receiver, it will be controlled by your present volume control and tone control. By mounting the mike on extender springs, this will eliminate the jar and packing of the granules, which will be amplified into the speaker. Remember this "chew-box mike" is experimental and not a commercial product. Hi!

Can YOU Answer These Radio Questions?

1. How are the circuits changed quickly in a transceiver to talk or receive? (See page 522)
2. Why are servicemen in demand in the aircraft industry? (See page 523)
3. Name at least three points of importance to watch in replacing condensers and resistors in "Wartime" servicing. (See page 524)
4. Why is it essential to test receivers at the normal line voltage for which the set is rated? (See page 526)
5. What are some of the things to watch out for in servicing personal sets in institutions? (See page 530)
6. What is a simple way to connect "hearing aids" in a theater sound-system? (See page 537)
7. Are you familiar with the recording of sound on paper discs? How long a recording can be made on one disc? (See page 538)
8. What is the effect in an electronic organ when the iron cores of the amplifier transformers are saturated with magnetic flux? (See page 540)
9. Why is it important to include "recorder" equipment in school sound-system installations? (See page 544)
10. What happens in resonant circuits? Does the tuned circuit have maximum impedance at resonance? If so, how does the detector receive sufficient energy to operate it? (See page 546)
11. What parts are needed to make a home-made photo-cell? (See page 548)
12. What tube is used to make an automatic voltage regulator? What else is needed besides a tube? (See page 551)
13. How would you construct a D.C. vacuum tube voltmeter? (See page 556)
14. What are the important steps in aligning an "FM" receiver? (See page 557)
15. How would you modulate a light beam with a voice current for an experimental photophone? (See page 566)
16. How does the new Hammond polarized beam tuning system operate? (See page 572)

U.H.F. Oscillator

(Continued from page 555)

parts used in the construction of the oscillator.

LIST OF PARTS

CONDENSERS

- One Hammarlund HF 35 mmf. condenser
- Four Aerovox .1 mf. tubular condensers
- One Aerovox 12 mf. condenser "Dandies"; 200 volts
- One Aerovox 16 mf. condenser "Dandies"; 200 volts
- One Aerovox .002 mf. mica
- One Aerovox .004 mf. mica
- One Aerovox .0001 mf. mica

RESISTORS

- Two I.R.C. 50,000 ohm, 1/4 watt
- One I.R.C. 2 meg. 1/4 watt
- One I.R.C. 50,000 ohm, 1 watt
- One I.R.C. 2250 ohm, 1 watt
- One Ohmite line-cord resistor
- One 280 ohm line-cord resistor

TUBES

- One RCA 25Z5 or 25Z6 rectifier.
- One RCA 6J5G or 6J5 metal tube.
- One Chassis 7x7x2 ins. Electroalloy
- One Kurz-Kasch bakelite vernier dial 3 ins.
- One 3000 ohm volume control and switch
- Two Hammarlund 2.5 mh. R.F. chokes

MISCELLANEOUS

- Wire, solder, bolts, nuts, 2 wafer sockets, 12 phone tips.
- Five Combination jacks, to take phone tips or banana plugs.
- One Clip (for cathode tap).

FM STATION SOUGHT FOR HOUSTON, TEXAS

FREQUENCY modulation for the largest city in Texas has been proposed through an application for an FM construction permit filed by The Houston Printing Corporation, publisher of *The Houston Post* and owner of standard station KPRC.

The new FM outlet would cover an area of 10,500 square miles, serving some 722,600 potential listeners who live within a 60-mile radius of Houston. A channel of 46.5 megacycles has been requested, and it is understood that the station would be an outlet of The American Network.

One other application for FM service in Texas is also on file, seeking a station in Amarillo.

There are now 63 commercial FM transmitters authorized throughout the country. Twenty-four are on regular schedules, along with eleven experimental stations. The latest list of these FM outlets together with applications pending, as compiled by FM Broadcasters, Inc., may be had by addressing the Editor of this magazine.

TELEVISION CONFERENCE CALLED

The Federal Communications Commission met in informal conference with television permittees and licensees and representatives of the Radio Manufacturers Association on April 9, in Washington, D. C., to discuss war-time television problems for the purpose of determining policies that may be followed regarding television broadcasting during the duration of the emergency.

The General Electric Company was granted construction permit (B1-PVB-88) on an experimental basis, for a new television relay broadcast station at New Scotland, N. Y., to operate on Channel No. 8, 162,000-168,000 kilocycles, 50 watts peak power and A-5 emission, for relaying programs to applicant's television station WRGB, replacing experimental relay television station W2XI.

Diagrams for

The Radio Experimenter

This is a new department. If you have a new Hook-Up, send it along; a pencil diagram will do. Be sure to include a brief description.

All diagrams and descriptions accepted and published will be awarded a year's subscription. Diagrams may be for receivers, adapters, amplifiers, etc. Send them to Hook-Up Editor, RADIO-CRAFT, 25 W. Broadway, New York City.

"LUNCH-BOX" RADIO RECEIVER

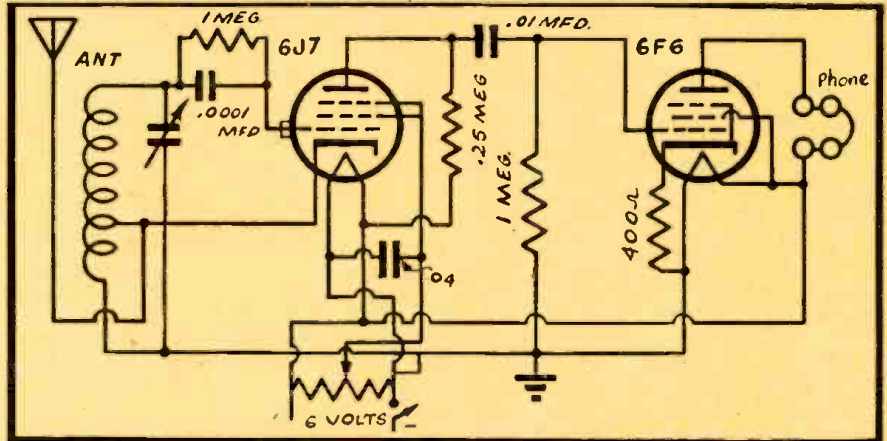

Richard Graham of Teaneck, N. J., sends us the diagram above of a two-tube portable receiver, operated from batteries. The whole outfit can be built into a "lunch-box." The author used different antennas, one of which consisted of a couple hundred feet of insulated wire, wound around a small pole 3 feet long. Another antenna was 40 to 50 feet of wire laid on the ground. The tuned antenna coil shown in the diagram comprises 120 turns of No. 30 enameled copper wire, wound on a 1/2-inch diameter insulated tube. No "B" battery is used.

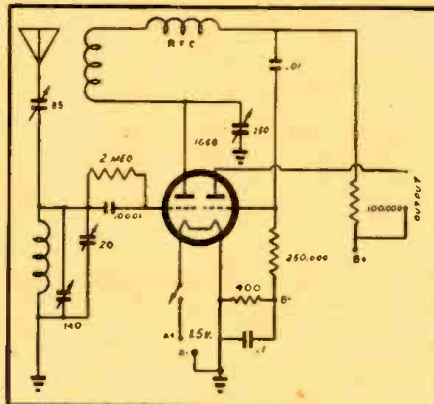

IMPROVED TWINPLEX HOOKUP

The diagram at the left shows an improved Twinplex one-tube receiver circuit devised by Leonard Klaffer of Newark, N. J. The tickler coil shown is connected to the first plate, and placed in an inductive relation to the grid coil.

AN "ALL-PURPOSE" AUDIO AMPLIFIER

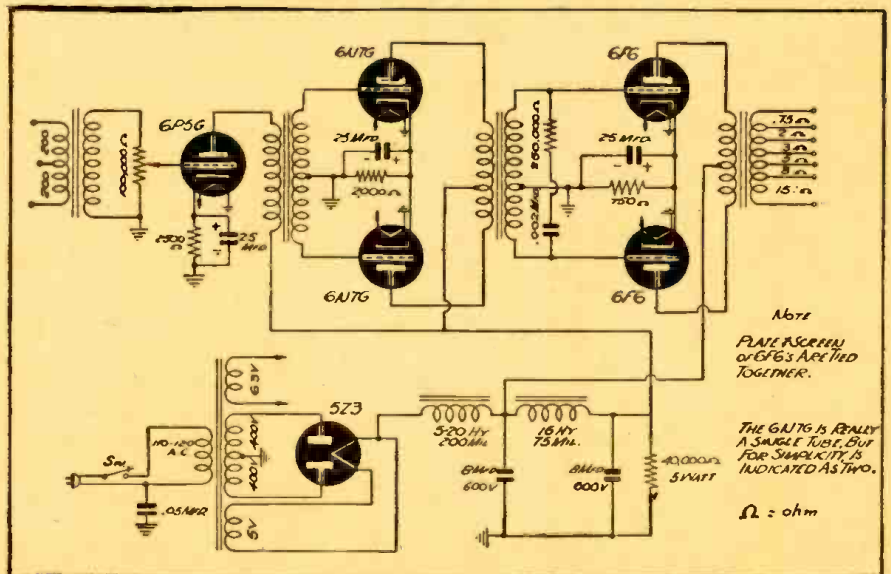

This amplifier can be used with low impedance microphones of the Amperite velocity type and with double-button carbon mikes. An input impedance of 400 ohms can also be obtained which, for all practical purposes, can be used for matching a 500 ohm line. The output transformer is universal and can match several different types of speakers. The power-supply uses an input choke that is capable of carrying 200 mls. Of course, a choke of this size is unnecessary. It is used due to the fact that another amplifier is operated off the same power-supply. The 6N7 is shown as two tubes for simplicity in drawing. The 6F6's have their screens tied to their plates.

Robert L. Cambron,
Gadsden, Alabama.

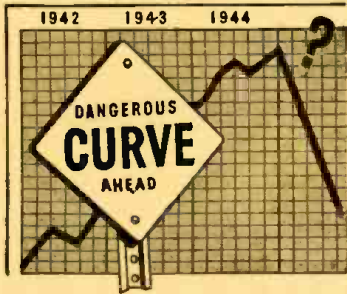

NOW is the time to make sure of the road ahead. After the present emergency, thousands of untrained, unprepared radiomen will be left behind. That's why CREI stresses the need now for a planned program of training . . . to increase your technical ability so that you will be in a position to command an important job when the inevitable readjustment comes after the war. Make your present radio job pay you dividends in the years to come by investing in a CREI home study course in Practical Radio Engineering and prepare for advancement, increased pay and security in your chosen profession.

WRITE FOR FACTS TODAY!

Our free booklet and personal recommendations may hold the answer to your success. In your inquiry, please state briefly your background of experience, education and present position.

CAPITOL RADIO Engineering Institute

Dept. RC-5, 3224 16th Street, N. W., Washington, D.C.

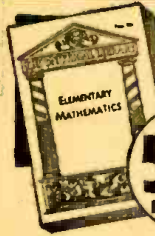

The Book that takes Drudgery out of Mathematics

Only 50c postpaid

SOLVES EVERYDAY PROBLEMS—HELPS YOU GET AHEAD IN LIFE

How many times have you lost money because of a mistake in figuring? Do you know how to figure quickly and correctly? Can you figure discounts, interest rates, taxes and all the other calculations you meet up with in your daily life?

Are you having trouble qualifying for Army or Navy promotion because you're not up on mathematics?

Here is the book that gives you a good background in mathematics; that takes all the irritation and drudgery out of it. You don't need to be scared of mathematics, because here's the subject explained without frills, without useless computations.

Here's the book for men in the armed forces; for business men; technicians and craftsmen, explaining and answering everyday mathematical problems in easy-to-understand words and illustrations.

Yes, it's the key to a simple understanding of mathematics. It's a real home-study course in mathematics for the man who's alert to the importance of mathematics in the world today.

ELEMENTARY MATHEMATICS

EASY—SIMPLIFIED—PRACTICAL

CONTENTS OF BOOK

- CHAPTER I. Arithmetic—Addition—Subtraction—Multiplication—Division.
CHAPTER II. Factoring and Cancellation—Fractions—Decimals—Percentage—Ratio—and Proportion.
CHAPTER III. The Metric System.
CHAPTER IV. How to Measure Surfaces and Capacity (Geometry).
CHAPTER V. Powers and Involutions—Roots and Evolution.
CHAPTER VI. Mathematics for the Manual and Technical Craftsman—Thermometer conversions—Graphs or Curve Plotting—Logarithms—Use of the Slide Rule.
CHAPTER VII. Special Mathematics for the Radio Technician.
CHAPTER VIII. Commercial Calculations—Interest—Discounts—Short Cut Arithmetic.
CHAPTER IX. Weights and Measures—Useful Tables.

ONLY 50c POSTPAID

Send Stamps, Cash or Money Order. Send today for your copy of this indispensable book. It can be carried readily in your pocket. (Size 6 1/2 x 3 1/2.)

TECHNIFAX

1917 S. State St., RC-542, Chicago, Ill.



FOR SUCCESS IN PHOTOGRAPHY

Profit by 32 Years of Experience

Learn quickly at world's largest, best equipped school. Full-time experts coach you INDIVIDUALLY. Quality now for this fascinating, well-paid field—cash in on big part photography plays in wartime industry. Resident or home study. Free booklet.

N. Y. INSTITUTE OF PHOTOGRAPHY, Dept. 11, 10 West 33 St., New York, N. Y.

COIL DATA

In my present receiver (home made) I am using the Pilot Coil switching unit. I believe this unit came out of the Pilot Converter (10 to 160 meters). The coils are wound on 1 inch coil forms and is quite a bulky object. I would like to do something about it.

I have ten quartz-Q coil forms 3/4 inch in diameter. Could you give me the coil data for these 3/4 inch forms, using a 2-gang 140 mmf. condenser?

In the unit I am now using there are three windings, one detector, one oscillator plate, and one oscillator grid. Would I gain by using the so-called Antenna winding on the detector coil? The switch is so built if I wish to use the winding.

The tubes I now use are 6I7 detector, and 6C5 oscillator. In your September "Question Box" you have a diagram of a super-het using a 6K8. I have an HF ceramic base bantam 6K8GT and I also have 2-182s. Would you advise using the one tube, or a single tube in each section?

I also have 2 Meissner 1500 kc. IFTs that I wish to use in place of the present 456 IFTs. Would you advise them?—G. B. Chieves, Bedford, Mass.

Tuning coil sizes for use with 140 mmf. tuning condenser.

Table with 4 columns: Detector Grid, Antenna Coil, Osc. Grid, Osc. Plate. Rows show turn counts for 78, 32, 15 turns and 25, 10, 5 turns for each column.

Detector grid and Osc. grid coils wound with size wire specified, enameled covered. Antenna and Osc. plate coils wound with #28 enameled wire.

You can use the single 6K8 tube as it will be simpler. If you substitute 1500 kc. IFTs, it will be necessary to experiment with the number of turns on the oscillator grid coil for proper "tracking."

AUDIO OSCILLATOR TUBE

Referring to the diagram of the variable tone audio oscillator shown on page 237 of the August issue, the second tube is labeled "76", but the "76" is a triode while the tube shown is a tetrode; can you set me straight on this matter?—L. N. Hultman, Rochester, N. Y.

The tube is actually a "76" but an error was made in showing the cathode as

a first grid. If the tube is recognized as being used simply as a rectifier, with the grid and plate tied together, the error is immediately apparent.

QUARTZ CRYSTAL MOUNTING

When using a tube socket as a receptacle for a plug-in quartz crystal, which two prongs are used?—F. Stark, Calumet, Mich.

When the five-prong socket is used, the plate and cathode contacts are used since these have the correct spacing to engage the crystal mounting pins (3/4" between centers).

PHONO-OSCILLATOR

What size coil forms were used in the Portable Radio-Phono oscillator shown on page 104 of the June issue?—F. Bamford, Orange, N. Y.

The coil form is a Radio-Crafter type "C" form, having a diameter of 3/4 inch and a length of 2 inches.

BAND-SWITCH TROUBLE

I have an 11-tube all-wave receiver that has given me continual trouble at the coil switch. I wonder if I could replace this band-switch with a series of small knife switches?—J. J. Meehan, Morton, Pa.

It would be practically impossible to replace the rotary coil switch with a number of knife switches, because of the much greater space that would be taken up by the knife switches. The lengthened leads also would result in much poorer operation due to higher losses, besides the inconvenience of so many switches to operate. Why not replace the old switch with a modern low-loss band-switch?

CRYSTAL TO WORK SPEAKER

Can you supply a diagram of a crystal receiver capable of operating a loudspeaker?—C. Caldwell, Tallahassee, Fla.

Without additional amplification, requiring the use of tubes, it is usually impossible to operate a loudspeaker from a simple crystal receiver.

10 BEST RADIO BOOKS 10 CENTS EACH

RADIO FANS EVERYWHERE—these fine ten cent text books give you an excellent foundation for the study of RADIO. They are clearly written, profusely illustrated and contain over 15,000 words in each book. You'll be

- No. 1—HOW TO BUILD FOUR DOERLE SHORT WAVE SETS
No. 2—HOW TO MAKE THE MOST POPULAR ALL-WAVE 1- AND 2-TUBE RECEIVERS
No. 3—ALTERNATING CURRENT FOR BEGINNERS
No. 4—ALL ABOUT AERIALS

amazed at the wealth of information contained in these handy books. Excellent for reference—ideal for every technical library. YOUR MONEY BACK if you are not satisfied. PROMPT SHIPMENTS

- No. 5—BEGINNERS' RADIO DICTIONARY
No. 6—HOW TO HAVE FUN WITH RADIO
No. 7—HOW TO READ RADIO DIAGRAMS
No. 8—RADIO FOR BEGINNERS
No. 9—SIMPLE ELECTRICAL EXPERIMENTS
No. 10—TELEVISION

BOOKS ARE ALL UNIFORM

Every book in the GERNSBACK EDUCATIONAL LIBRARY has 32 pages—with illustrations varying from 30 to 66 in number. Each title volume contains over 15,000 words. Positively radio's greatest book buys! If you do not think these books worth the price asked, return them in 24 hours and your money will be instantly refunded.

RADIO PUBLICATIONS • 25 WEST BROADWAY • NEW YORK, N. Y.

RADIO PUBLICATIONS, Dept. RC-5-42, 25 WEST BROADWAY, NEW YORK, N. Y.

Gentlemen: Please send immediately, POSTPAID, the book numbers circled below. I am enclosing cents—each book being 10c.

1 2 3 4 5 6 7 8 9 10
NEW NEW

Send FREE listing of 48 new 10c publications.

Name Address

City State
Remit by check or money order—register letter if you send cash or unused U. S. postage stamps.

MAIL COUPON TODAY!

AN AUSTRALIAN RECEIVER HOOK-UP

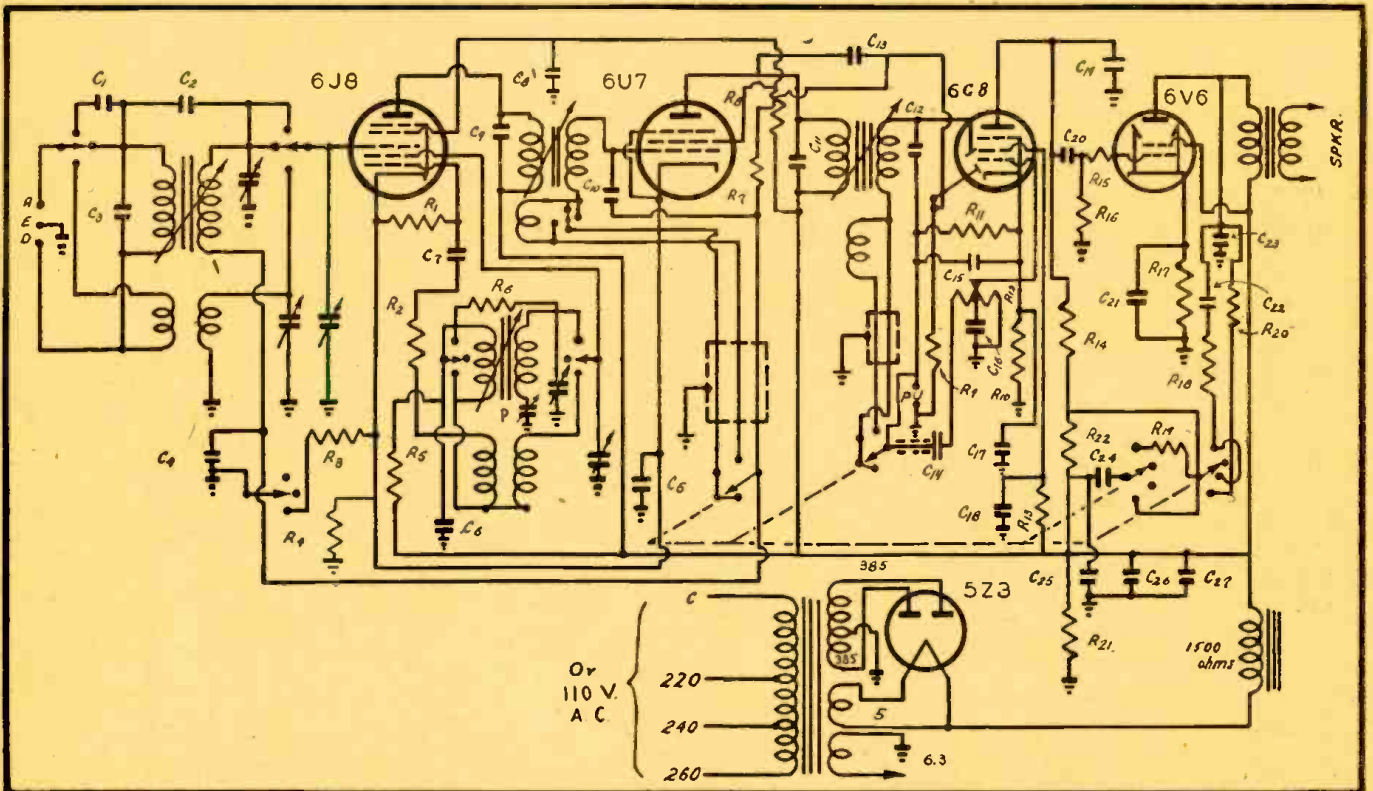

5-Tube, Dual Wave Receiver.

● IF you want a \$150 receiver such as are commercially sold for that figure in Australia, follow this diagram taken from an article by A. G. Hull in *Australasian Radio World*. It is known as The Breville Radio, Model 237.

The author points out that while it appears to be an ordinary 5-tube dual-wave receiver, it has several improvements which make a very real contribution to the set's performance. He states that it has plenty

of sensitivity on the short waves, with sharp selectivity and really high fidelity reception on the broadcast band.

The 6J8G is mounted in a special cushion socket and gives frequency stability down to 13 meters. Easy tuning on the short waves is obtained through variable selectivity IFT's. On the short wave setting of the wave band switch, these transformers are automatically switched to give maximum gain and broadest tuning, so that the set

is not too critical on the high frequencies. They also help in getting high fidelity on broadcast programs.

Inverse feedback, tone control and compensated volume control are used in the audio amplifier to assure full brilliance even at low settings of the volume control. The tone control functions on the inverse feedback circuit and can be set to attenuate the middle register, thus affording exceedingly brilliant response. The values of all components are shown in the diagram.

RADIO PATENT REVIEW

Radio Tuning Apparatus

2,250,761 issued to Edmund A. Gschwind, Chicago, Ill.

● A NEW and improved push button tuning mechanism, and more particularly a tuning mechanism especially adapted for use with radio receiving sets.

The present commercial type of radio broadcast receiver comprises a tuning element, such as a variable condenser, which requires very accurate adjustment to tune in a desired station properly and with good tone quality. A push button tuner for such sets must therefore be capable of rotating or otherwise moving the associated tuning element with a great degree of accuracy and with uniformity of movement in repeated use. Cost limitations in commercial practice require a tuner to be produced in quantities at a minimum of expense. This requires in turn that the parts of the tuner

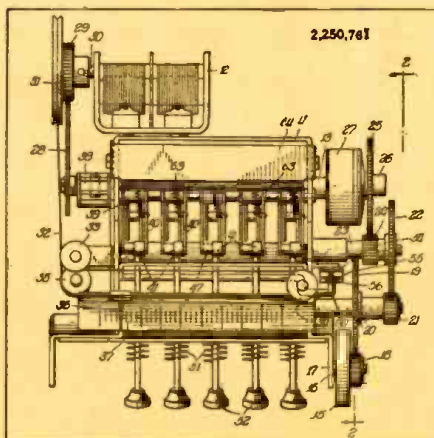

The drawing above shows an improved push button tuning device for use with radio receivers. The push button rods are independent of the mechanism which rotates the tuning condenser.

be capable of production without working to extremely close tolerances.

It is an object of the present invention to provide a new and improved push button tuner which is simple in design and operation and adapted for commercial production.

Another provision is a construction in which the push rods or push button slides are independent of the mechanism for rotating the tuning element.

A third feature gives a construction in which separately supported actuating members are interposed between the push rods and the rotary cam shaft connected to the tuning element.

Independently supported and co-acting operating levers actuated jointly by the push rods, is another purpose of this invention; also parts which do not require close dimensional tolerances to operate accurately and uniformly.

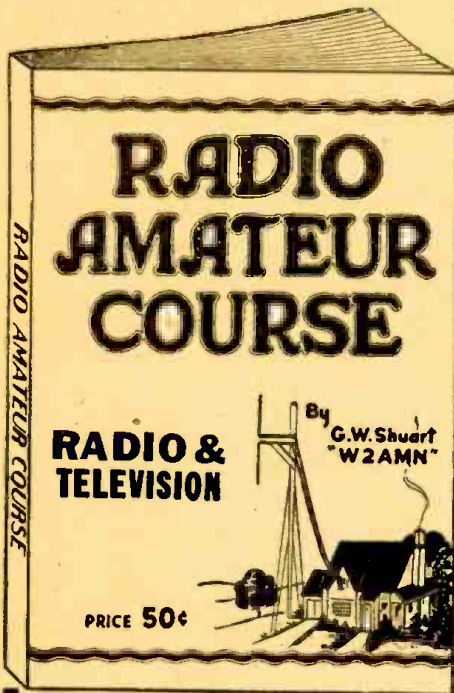

Your Money Back—
 If the **RADIO AMATEUR COURSE** does not represent the greatest book value ever offered to the radio "fans" for **50c**

To convince you that there isn't a better book buy today, the publishers of the **RADIO AMATEUR COURSE** make the sensational offer of a money-back guarantee on such a low-priced book. Stop in at any of the many dealers handling this book and examine it. See for yourself if the **RADIO AMATEUR COURSE** isn't just the book you've always wanted.

Printed on the finest coated paper—well illustrated attractive 4-color cover—complete with radio information you must have. It contains a step-by-step program for obtaining a short-wave radio education.

Written by **George W. Shuart, W2AMN**
 foremost short-wave authority

148 PAGES
 6 x 9 INCHES

OVER 150 RADIO DIAGRAMS
 and **TECHNICAL PHOTOGRAPHS**

RADIO AND TELEVISION
 25 West Broadway New York, N. Y.

RADIO AND TELEVISION
 25 West Broadway, New York, N. Y.

Gentlemen: I enclose herewith my remittance of Fifty Cents (50c) for which please send me **POST-PAID**, my copy of the **RADIO AMATEUR COURSE**. (Remit by check or money order; register letter if you send cash or unused U. S. Postage stamps.)

Name

Address

City State RC-5-42

POLARIZED TUNING SYSTEM

No. 2,272,839 issued to John Hays Hammond, Jr., Gloucester, Mass.

This invention pertains to an improved radio transmission system for producing two carrier waves of the same frequency, but with different planes of polarization, the phases of the radiations having any desired relations.

The invention also provides polarized receiving means, which may be rotated so as to eliminate any undesired interference, without interfering with the reception of the desired signal.

The present method accomplishes selectivity of transmission against intentional or other interference by similar signals of the same carrier frequency, and may be practised with any type of communication such as continuous wave telegraphy or telephony, facsimile transmission, etc.

In the diagram shown an ultra shortwave transmitter is provided with two radiators or antennas, one transmitting a beam of waves in a horizontally polarized plane,

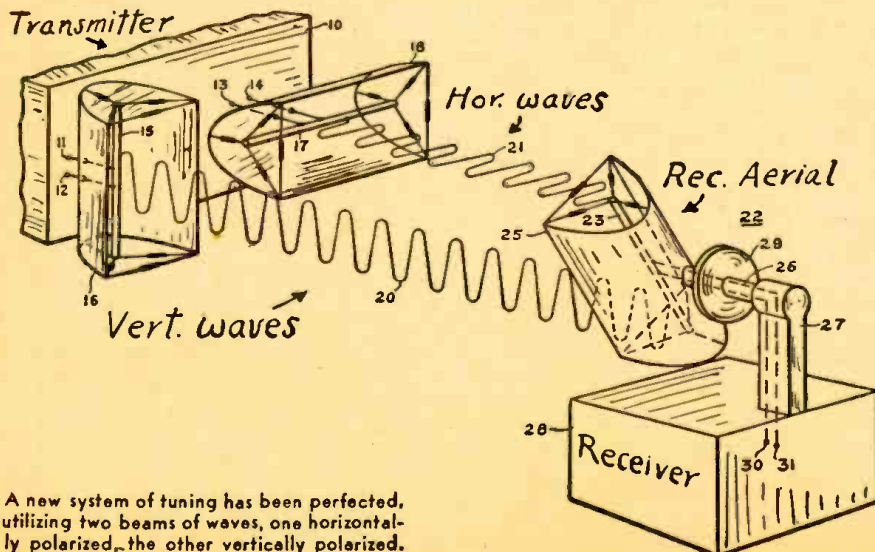

A new system of tuning has been perfected, utilizing two beams of waves, one horizontally polarized, the other vertically polarized.

while the other transmits a beam of waves vertically polarized. By suitably turning the radiators and their reflectors, the respective polarization plane of either of the wave beams may be changed. The two radio beams are concentrated on to a single collecting antenna system, shown at the right and the receiving antenna and its reflector may be rotated to any required angle. By rotating the receiving antenna and its reflector, it becomes possible to make the receiver respond to either the vertically polarized or the horizontally polarized radiation, or in part to both.

Since interference in general is usually of plane polarized nature, it is evident that by rotating the collecting antenna system until its axis is perpendicular to the plane of polarization of the interference, it is possible to eliminate this interference almost entirely, without affecting the intensity of the desired signal from the transmitter.

It is thus seen that this arrangement provides a means of transmission and reception quite free from disturbances of plane polarized radiation, of the same frequency and general nature as those being conveyed; thus an added method of selectivity is provided over and above any selectivity which may be provided by the nature of the transmitting and receiving circuits.

TELEVISION IMAGE PROJECTOR

No. 2,276,750 issued to Manfred von Ardenne.

This invention covers a television image projection system, wherein optical means are provided for projecting a television

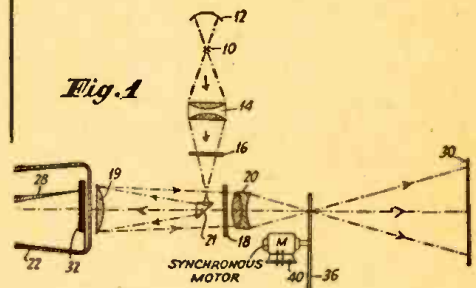
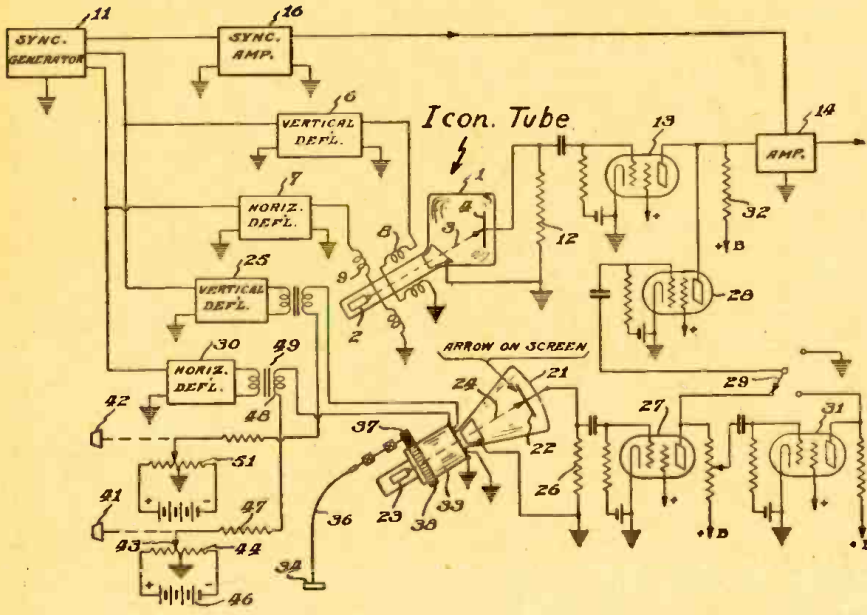

image upon a viewing screen. Contrary to the usual television projection method, with this invention the image is sustained uniformly as a whole on the projection screen. The disappearance or absence of each individual line of the entire screen occurs during a brief time period only, as compared to the customary duration of the individual lines, which for example, may be only 5 to 10 percent of the duration of the frame image.

Despite the briefness of this period of darkness in the devices disclosed, says the inventor, a flickering is noticeable, especially where the field or frame frequency is low (for instance 25 and less). This condition persists even though the period of darkness does not occur simultaneously over the entire image but exists in the form of a moving dark band over the image field in accordance with the formation of the image in a line by line manner. The elimination of this disturbance is of particular importance because with such elimination the operation can be carried out with the smallest number of images or frames per second which is possible to reproduce the movement so that an especially narrow frequency band of the transmission channel will be sufficient. Furthermore, lower carrier frequencies may be used.

It is proposed to eliminate the disturbance due to flickering by introducing an intermittent projection similar to that in ordinary moving picture projectors.



TELEVISION INDICATOR

No. 2,275,026 issued to Alda V. Bedford, Collinswood, N. J.

Often times it is desirable to point out a certain figure or object on a television image screen by means of an arrow, during a lecture, for example. This invention provides an electrical means whereby an indicating arrow may be caused to appear on the television screen at the receiver and at any desired location on the screen. The inventor does this by utilizing a second cathode ray tube in which the position of an arrow can be selectively picked up and the currents corresponding to this arrow (image) superimposed on the signal emanating from the iconoscope or regular image pickup tube. By providing the proper deflection control means, associated with the cathode ray tube generating the signal representative of the

arrow, the transmitter operator may position the arrow at will in the field of the television picture. In the case of the auxiliary cathode ray tube in which the image of the arrow is scanned, the deflection of the scanning ray is accomplished by means of a pair of deflecting coils, located in a deflecting yoke, which is rotatably mounted on the neck of the cathode ray tube. The arrow or other indicating symbol may be rotated at the will of the operator by means of a suitable control knob; this knob when rotated also causes the deflecting yoke to be rotated. Means are also provided for moving the indicating symbol sideways or up and down on the picture at will; by adding or subtracting a stage of amplification, the arrow may be made black or white.

RADIO DISTANCE METER

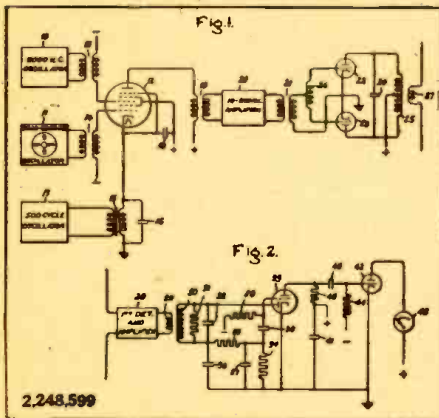

2,248,599 issued to E. F. W. Alexander, Schenectady, N. Y.

IT has been found that radio waves may be used to measure the distance between two points with very simple apparatus, by the use of a new and fundamentally different method. In practicing the present invention, waves of very high frequency are propagated toward the object whose distance from the observer is to be measured and standing waves are thus created. The frequency of the propagated waves is varied

cyclically with such extreme rapidity, that the waves which have been transmitted and reflected back to the transmitter arrive at it at the instant, when it is again transmitting waves having a recognizable frequency characteristic with respect to the reflected waves. The frequency with which the frequency of the radiated waves is varied is then a measure of the desired distance.

In Fig. 2 there is illustrated a receiver which is designed to indicate the intensity of beat frequency components between the transmitted wave and the wave reflected from the surface whose distance is being measured. When the frequency of the reflected wave returning to the receiver corresponds closely at all times to the frequency of the wave passing directly from the transmitter to the receiver, there are a minimum of beat frequency or heterodyne components. Conversely, when the frequency of the oscillator of Fig. 1 varies at such speed that the reflected wave reaching the receiver attains its lowest frequency, at the instant when the wave coming directly from the transmitter attains its highest frequency, there are a maximum of beat frequency components. Either of these conditions may be used to indicate distance.

AIRCRAFT NAVIGATION

2,245,246 issued to Ernst F. W. Alexander, Schenectady, N. Y.

THIS invention is a system comprising a series of trail transmitter stations spaced at relatively wide intervals along the predetermined cross-country flying course or trail, and arranged to transmit course radio signals and altitude radio signals, and similar transmitter stations, located at the landing fields and arranged to transmit course signals and altitude signals along the predetermined glide paths leading to the landing fields from the cross-country course or trail.

The course signal antennas at each station both along the cross country trail and at the glide paths are preferably so arranged as to provide at each station two beams directed horizontally with vertical polarization, the beams being directed respectively a predetermined number of degrees to the right and left of the course. A dot-dash method of keying the course signal antennas is preferably employed.

The altitude signal is radiated at each station by two antennas, spaced apart in the direction of the course, and each providing a radiation directed upwards with a sharp directivity in the direction of the course but spreading fan-shape along the course. The two altitude beams at each station create an interference pattern in space, so that the signal periodically disappears when the plane flies through the pattern.

The system provides, on the aircraft, a course and altitude signal receiving means which preferably comprises a single receiver apparatus. For the course signal indication the receiver apparatus includes a visual course indicator of the dot-dash type, wherein the instrument needle goes to the right or to the left if the aircraft is off course, but remains on neutral when the aircraft is on course. For the altitude signal indication the receiver apparatus includes means, preferably providing a visual indication, responsive to the pulses created in the radio receiver by the interference pattern which is set up by the altitude signal transmitter. The altitude indicating means is so arranged that in flying the aircraft through an interference pattern of a given form, for a predetermined ground speed, the instrument indicates directly in response to the pulsation frequency whether the aircraft was at the correct altitude as it passed through this interference pattern.

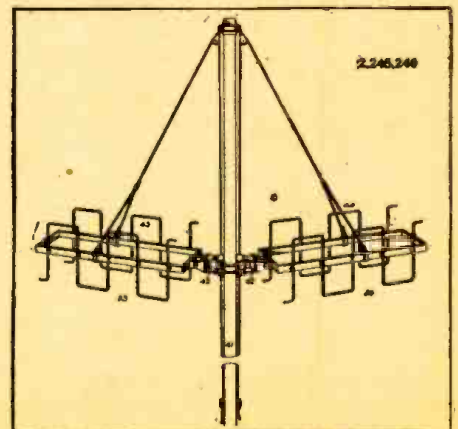

DATAPRINTS



TESLA-LOUDIN COILS

20c Ea. in order for 10
(Data and Drawings only.)
36" Sp'k Tesla-Oudin Coil 40c
(1 K.W. Exc. Trf. Data incl.)
8" Sp'k Tesla-Oudin Coil 40c
(1/4 K.W. Exc. Trf. Data incl.)
3/4 Sp'k Oudin; 110 Vt.
"Kick Coil" type.... 40c
8" Tesla Works on Ford
Coil..... 40c
1" Sp'k Vibrator Hi-Freq. Coil 40c

NEW! 5 ft. Sp'k. Oudin Coil & Exciter
Data 75c



Induction PIPE & ORE LOCATOR

Induction Type. Data 40c
Radio Type 40c

More DATAPRINTS 40c each!

5 Meter Superhet.	Electric Refrigerator
1/2 Meter Tr. & Rec.	Wheatstone Bridge
20 A.C. Probs. & Ans.	Weld. Transf. 2 K.W.
20 Telephone Hook-ups	Rewinding Armatures
100 Mech. Movements	String Galvanometer
20 Motor Hook-ups	20 Simple Bell Circuits
Television Hook-up	Steel Wire Recorder I
20 Elec. Party Tricks	Water Wheels
Solenoids and Magnets	Water Turbines
-get list.	Photo Cell and Relay
Fry Eggs on Ice!	Ring 4 bells: 2 Wires
Experimental Photophone	20 Tesla Tricks
Radio Control for Models	Polarized Relay
Diathermy Apparatus	Induction Balance
Inductor Organ	Electric Pipe Thawer

Special Prices: 4 prints \$1.00; 10 for \$2.00;
Single, 40c each. Get New Catalog 100 A.

The DATAPRINT Co.

Lock Box 322D, Ramsey, N. J.

OPPORTUNITY AD-LETS

Advertisements in this section cost 15 cents a word for each insertion. Name, address and initials must be included at the above rate. Cash should accompany all classified advertisements unless placed by an accredited advertising agency. No advertisement for less than ten words accepted. Ten Percent discount six issues, twenty percent for twelve issues. Objectable or misleading advertisements not accepted. Advertisements for June, 1942 issue, must reach us not later than May 10, 1942.

Radio-Craft - 25 W. B'way - New York, N. Y.

EDUCATIONAL COURSES

CORRESPONDENCE COURSES AND EDUCATIONAL
books, slightly used. Sold, Rented, Exchanged. All subjects. Satisfaction guaranteed. Cash paid for used courses. Complete details and bargain catalog FREE. Write NELSON COMPANY, 509 Sherman, Dept. C-242, Chicago.

ONE, TWO AND THREE-TUBE SET PLANS: "Tello", "Tellotron", "Tello-Bulldog", "Radio-Bulldog", "Radio-Tello"—All 25c. Telloradio, 524 Fairbanks Avenue, Oakland, California.

WANTED: RIDER MANUALS, TESTING EQUIPMENT,
etc. Walter Wiehner, Bloux Falls, S. C.

SPOT CASH UP TO \$5.00 FOR NEW RADIO INVENTIONS. Tellotron, 524 Fairbanks Avenue, Oakland, California.

Do you need BINDING POSTS?



The XL PUSH POST with its Spring Action assures Constant Contact and quick connection.
Manufactured in All Aluminum Type M at 12c each.
Aluminum Body, Bakelite Top Type S1 at 12c each.
Types CP or MP. ALL BRASS-STAINLESS STEEL SPRING & PIN. PROVEN BY 240 HR. SALT SPRAY TEST as NON-CORROSIVE at 25c each.

Manufacturers and Dealers Liberal Discounts

X. L. RADIO LABORATORIES

420 West Chicago Ave., Chicago, Ill.

Correspondence Courses in RADIO and ELECTRICAL ENGINEERING

ELECTRICAL ENGINEERING Get good grasp of wide electrical field. Prepare yourself, at Low Cost, for secure future. Modern equipment included. COURSE IN RADIO. **RADIO ENGINEERING** Extra fine course in radio, plus license. Includes address, photo-electric work. Trains you to be super-service man, real vacuum tube technician. Exper. kits furnished. Diploma on completion. **Tuition, \$25**, either course. Deferred payment plan. **FREE** Get school catalogs, student magazines, complete details. **SEND NOW!**

LINCOLN ENGINEERING SCHOOL Box 931-C48, LINCOLN, NEBB.

Plaque Award Announcement

THE editors are pleased to announce that the handsome plaque previously awarded for photos of the best amateur radio station will be hereafter awarded to the person submitting the best photo of a Radio Listening station (or post). If you are a short-wave listener, here is a good opportunity to win the plaque which this magazine will award each month for the best photo received. The photo should be accompanied by a 300-word description, explaining the type of aerial or aerials used, their dimensions and arrangement, the make of receiver used and whether or not any recording device is available for making

a record of code or phone messages picked up.

If the owner of the "listening post" is a member of a local defense unit, he should also state this in his letter. (The editors will be pleased to receive articles on the subject of local defense, written from a radio listening post angle.)

The photos of your "listening post" should include the owner's picture or otherwise a small photo of the station owner may be enclosed with the picture of the outfit. The pictures must be sharp and clear and should not be smaller than 5 x 7 inches.

Here is the "Award of Honor" Plaque which measures 5" x 7" in size. It is handsomely executed in colors on metal, and is framed, ready to hang on the wall. The name of the winner will be suitably inscribed.

FOR THE DURATION OF THE WAR—Plaque will be awarded for best "Listening Post" photo.

Attach a brief description not longer than 300 words, describing the general line-up of the apparatus employed, the size, type and number of tubes, the type of circuit used, name of commercial receiver — if not home-made.

State briefly the number of continents heard, the total number of stations logged or contacted, and other features of general interest. Mention the type of aerial system.

Important — Enclose a good photograph of yourself, if your likeness does not appear in the picture!

You do not have to be a reader of RADIO-CRAFT in order to enter the contest.

Address all photos and station description to Editor, "Listening Post" Photo Contest, c/o RADIO-CRAFT, 25 West Broadway, New York, N. Y.

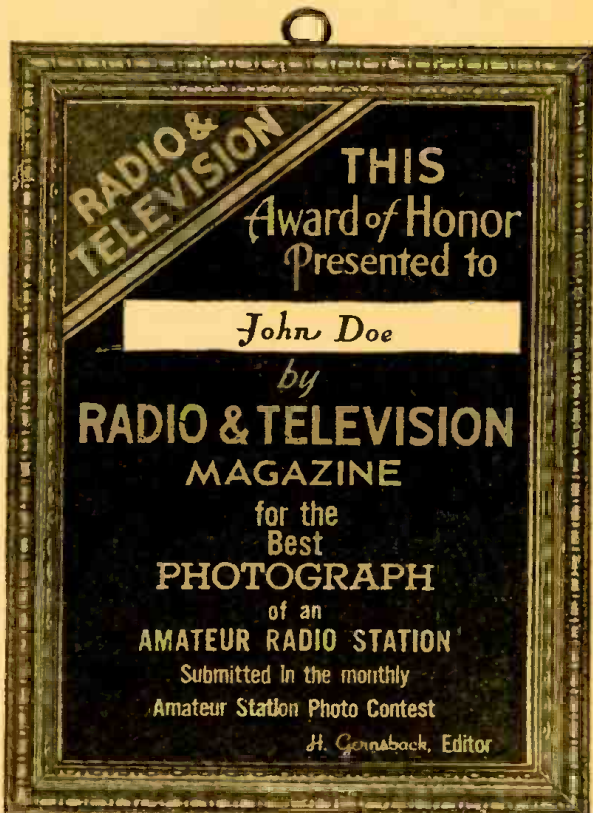

MORE "HAM" LICENSES ISSUED

The F.C.C. is now ready to issue the 1500 operator licenses which have been earned since December 7 and which have been held on their desks since that date. This number will bring the total number of amateurs close to 60,000. Of this number, it is estimated that more than 10,000 are already in military communications service. The object of this release of licenses to successful candidates is to replenish the supply of technicians and communicators for both military and non-military radio openings.

A "ham ticket" has long been recognized as the "open sesame" to a good radio job; today it is the virtual equivalent to a diploma or even a college degree, if one may judge by the special ratings and pay open to hams in military service and the number of calls for qualified amateurs received from the radio industry daily at the headquarters office of A.R.R.L. "Ham tickets" can be used as qualification for admission to advanced military grades. The Navy grants immediate rating as radioman, second class, equal to four full promotions over the normal entrance rank, to holders of amateur Class A or B. Likewise, the Army offers specialist ratings in communi-

fications work in its signal corps for qualified amateurs.

Non-military government radio openings also often specify the holding of an amateur license: One bureau wants qualified amateur radio operators capable of handling 25 w.p.m. in code. The F.C.C. wants amateurs "to augment the Commission's staff in patrolling the radio spectrum and detecting and locating illegal and subversive radio stations." When the supply of professional radio engineers was exhausted many months ago, the radio industry turned to the amateur body as constituting the only other personnel trained in radio communication. In particular, amateurs are being called for by companies engaged in the production of "radiolocator" gear, an entirely new radio technique, since hams have long been noted for their ability at improvisation and quickness to grasp new ideas.

If you need more information concerning the jobs, both military and non-military, contact A.R.R.L., giving such salient facts as your qualifications, the kind of job preferred, salary expected, etc.—(From A.R.R.L., with interscription by the editor of "The Arc," Asheville, N. C.)

A FEW DUMMY ANTENNAS

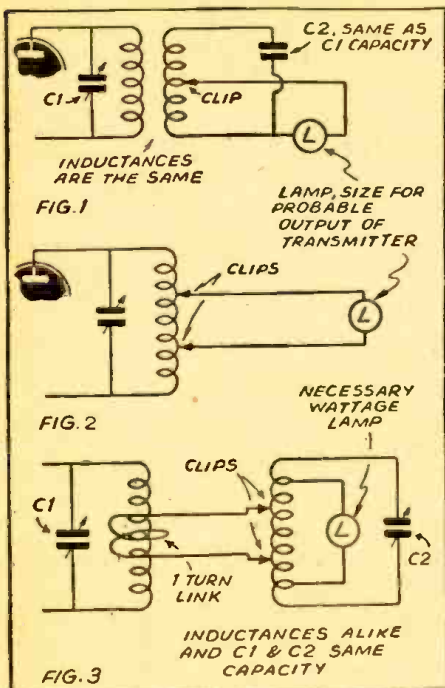

Various hook-ups of dummy antennas.

● THE office of a dummy antenna is to save "jamming" the air with test signals and to act with similar characteristics as the antenna, so tests can be made in tuning up the rig. Its make-up is a matter of resistance and capacity to match the "sky-wire" and can be composed of pure resistance such as the non-inductive type or an electric lamp which is better for amateur use because it gives visual indication. The capacity can be any suitable condenser. An inductance should be used to match that of the transmitter tank.

In No. 1 a second inductance is used similar to the tank coil with a variable condenser the same as C1. The lamp is in circuit with a clip on the inside lead. This is clipped at various points along the coil until the transmitter final is drawing the rated number of mils. At the same time the lamp should reach a peak brilliancy. Compared to its brilliancy on the light lines will indicate roughly the output of the rig.

In No. 2 is indicated a simple rig, untuned. When the lamp's brilliancy reaches maximum with the tube plate running at normal such a dummy is functioning properly.

No. 3 shows a dummy antenna that better approaches the desired state of efficiency. A link connects the tank circuit to the dummy inductance. Both inductances are alike, as are C1 and C2. One or two turns of the link are wrapped around the cold end of the tank and by means of clips, attach to as many turns as are necessary on the dummy inductance. One or two each side of the center is about right. Sufficient lamp wattage is then clipped to the inductance as indicated. The lamp wattage should approach that of the transmitter's output. When the condenser C2 is operated and the clips are properly placed, with the tube drawing normal currents, such a dummy will more truly function as a normal antenna—without radiating. Its action is sharper than the two former and resonance with the transmitter more clearly defined.

A good dummy antenna is as necessary to a station as a good monitor and frequency meter. Tests can be carried on for hours without interfering with others on the air and the transmitter brought to a stage of perfected operation, just as though the regular antenna was being used.—L. B. Robbins.

17 CENTS PER FOOT ANTENNA!

Here's a wonderful vertical antenna which costs less than 17c per foot. The only materials needed are as follows:

- 1 Permax 10 meter vertical steel mast (No. 318-M)
- 1 twenty foot 2" x 2" wood pole
- Enough single or double transmission line to receiver
- Sufficient guy wire to hold mast steady when winds blow
- You will also need 3 pieces of wood size 4 x 6 x 1 boiled in paraffin.

The diagram illustrates everything in the construction of this antenna. A few pointers, however—it would be advisable to give the wooden pole two coats of paint to resist the weather. Care should be taken when putting up the mast, as it isn't quite as easy as it looks. Perhaps you can get someone to help you and do the job right. The antenna I have here has been in use close to about one year and the results have been amazing, not only on the ultra high frequencies, but on the other bands as well. I have even used this antenna to transmit, as it radiates well on the ultra high frequency bands. It can be used 1/4 wave on 10 and 20, and 1/2 wave on 5 and 10.—Biago Trimboli

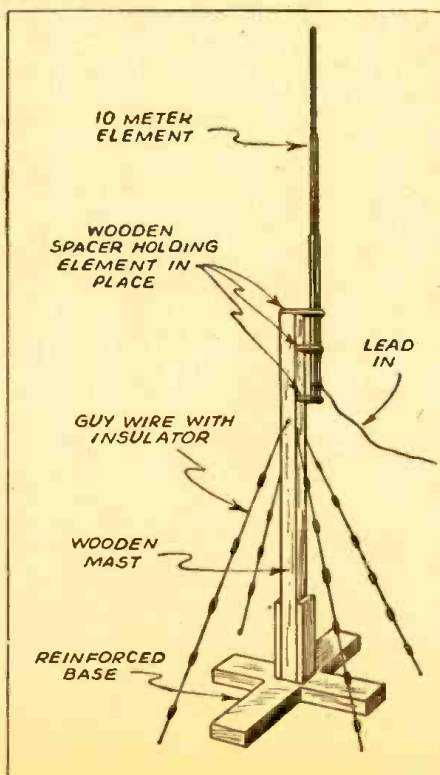

Yes! There's a SHORTAGE of RELAYS by GUARDIAN now being diverted to DEFENSE...

★ Guardian products and Guardian engineering have been recognized and accepted by the U. S. Armed Forces to such an extent—that unless yours is a defense job, we find it impossible to furnish some of the best relays Guardian has ever produced. If we only could, Man, what a rig you'd have!

A year ago, you couldn't have bought relays with the high capacity and small size that Guardian is furnishing to our fighting forces today. So, keep a date with the best relays ever built when you're back at your rig in 1947.

RELAYS by GUARDIAN

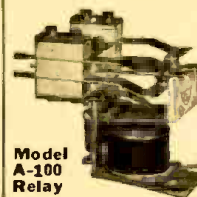

Model A-100 Relay

Guardian's contributions to radio defense are in the "walkie-talkie", tank radios, radio directional navigation, and a lot of "gimmicks" and "gadgets". They have more of a lead on old practices than the retreating Nazis* have on the Russians!

*Guardian is going ahead!

RADIO AMATEUR RELAYS

- Standard A-100, A-100-C, Antenna Relays AISIMag Insulated Operate on 110 V.—50 to 60 cycles A.C.
- A-100 Double Pole—Double Throw
- A-100-C Single Pole—Double Throw
- (R-100 Relay AISIMag Insulated. Same Rating as the A-100 Relays.)
- R-100-C Single Pole—Double Throw
- R-100 Single Pole—Single Throw

See Your Jobber Before Stock on Hand Is Depleted.

GUARDIAN ELECTRIC

1622 West Walnut Street Chicago, Illinois
DEFENSE
LARGEST LINE OF RELAYS SERVING AMERICAN INDUSTRY

Headset Headquarters



Our Headphones are used by the United States, Canadian, New Zealand and South African Governments as well as other Governments not directly in the war. Folder C-5 illustrates rugged, unusually sensitive, dependable Cannon-Ball Headsets. Write ..

Scientifically Built Heavy horn magnets greatly increase their efficiency.

C. F. CANNON COMPANY SPRINGWATER, N. Y.

RADIO ENGINEERING,

broadcasting, aviation and police radio, servicing, marine radio telegraphy and telephony. Morse telegraphy and railway accounting taught thoroughly. 48 weeks' Engineering course equivalent to 3 years of college radio work. All expenses low. Catalog free. School established 1874. The Dodge Institute, Monroe St., Valparaiso, Ind.

**NOW—A REALLY HIGH-POWERED—
Radio Engineering
Library**

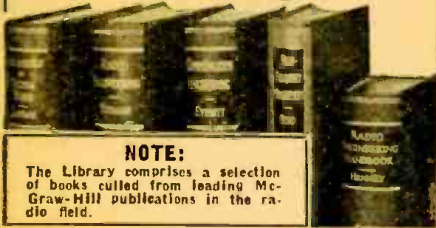

NOTE:

The Library comprises a selection of books culled from leading McGraw-Hill publications in the radio field.

- especially selected by radio specialists of McGraw-Hill publications
- to give most complete, dependable coverage of facts needed by all whose fields are grounded on radio fundamentals
- available at a special price and terms

THESE books cover circuit phenomena, tube theory, networks, measurements, and other subjects—give specialized treatments of all fields of practical design and application. They are books of recognized position in the literature—books you will refer to and be referred to often. If you are a practical designer, researcher or engineer in any field based on radio, you want these books for the help they give in hundreds of problems throughout the whole field of radio engineering.

5 VOLUMES, 3319 PAGES, 2289 ILLUSTRATIONS

1. Eastman's FUNDAMENTALS OF VACUUM TUBES
2. Terman's RADIO ENGINEERING
3. Evertitt's COMMUNICATION ENGINEERING
4. Hund's HIGH FREQUENCY MEASUREMENTS
5. Henney's RADIO ENGINEERING HANDBOOK

10 days' examination. Easy terms. Special price under this offer less than books bought separately. Add these standard works to your library now; pay small monthly installments, while you use the books.

10 DAYS' FREE EXAMINATION—SEND COUPON

McGraw-Hill Book Co., 330 W. 42nd Street, N. Y. C.

Send me Radio Engineering Library, 5 vols., for 10 days' examination on approval. In 10 days I will send \$3.00 plus few cents postage, and \$3.00 monthly till \$24.00 is paid, or return books postpaid. (We pay postage on orders accompanied by remittance of first installment.)

Name

Address

City and State

Position

Company RC-5-42

**MATHEMATICS
FOR RADIO**

AND COMMUNICATION

by **GEORGE F. MAEDEL, A.B., E.E.**
Chief Instructor, N.Y. School, RCA Institutes

To master the technicalities of radio—to read engineering literature intelligently—you must have the mathematical groundwork covered by these absorbing books prepared for home study. Book I (314 pp.) covers the algebra, arithmetic, and geometry; Book II (329 pp.) covers the advanced algebra, trigonometry, and complex numbers; necessary to read technical books and articles on radio.

MAEDEL PUBLISHING HOUSE Room 117
593 East 38 Street, Brooklyn, New York
Send me Mathematics for Radio and Communication as checked below. I enclose payment therefor with the understanding that I may return the book(s) within 5 days in good condition and my money will be refunded.

Name

Address

- Book I at \$3.75 plus 3c postage
- Book II at \$4.00 plus 3c postage
- Books I and II at \$7.75 postage prepaid (Price in Canada, 25c higher per volume.)

Hints for "FM" Listeners

MR. J. O'CONNOR
Zenith Radio Corp.

DURING the past several years certain foreign critics have put themselves on record with the assertion that America is a nation of "tin ears." It is true that we have grown up more than any other social group with radio and have accepted the standard radio reception, lacking the nuances and the fine filigree of tone that stopped short of the air waves, as a standard for our musical appreciation.

The result is that many, upon hearing FM for the first time, find it somewhat brittle. This is especially true of those whose tone controls are always set for the heaviest bass. Some conditioning is necessary before these persons really appreciate the realistic qualities of frequency modulation broadcasts.

Everyone interested in FM demonstration—salesman or proud FM radio owner—should make note of this fact. Wherever possible choose an FM program that is also being aired over the standard station, and tune sharply from FM to AM. The result is immediately noticeable and conclusive.

* * *

Zenith FM engineers have found a simplified means of overcoming interference in areas distant from the transmitter, although not at extreme range. By simply connecting two wires, 5½ feet long to the FM antenna posts and extending them in a vertical position, they gain much the effect of an outside antenna without undertaking the difficult installation.

* * *

When we speak of "extreme range" or "horizon" we speak of no set radius from the transmitter. Unlicensed FM sets tested by Zenith engineers in the laboratories and in the field were found to have greatly reduced horizons to those which contained all of the elements of the Armstrong circuit. Interference centers also shorten the range of all receivers, but of course this too is in proportion to the extreme range under ideal conditions.

The simple antenna installation mentioned above will be of great benefit to reception under many conditions. There is no substitute for the outside antenna, however.

In erecting the outside antenna, the polarization of the transmitters must be kept in mind. Virtually all of the American FM stations are to have horizontal polarization, although many of the "experimental rigs" are using "buggy whips" with vertical polarization temporarily.

Correct polarization and height above the ground are two most important qualifications for the FM antenna. Another is the length of the lead-in, which should be as short as possible.

For extreme ranges a reflector in addition to the standard dipole antenna will give even greater signal-to-noise ratio.

One quality of FM much appreciated by the average listener is its ability to give the reproduction its full sound complement at reduced volume. A second feature is the penetration of this sound, which coming from speakers incorporating the high frequency diffuser, permeates several rooms without objectionable volume.

* * *

The realistic qualities of FM herald a revolution in the quality of all broadcasting of the future. Better music with finer and more complete orchestras will be demanded more and more by the listening public. The Federal Communications Commission has set high standards of FM transmission that has put the listener and prospective listener entirely on his own.

BIG FREE CATALOG

EVERYTHING IN RADIO

Sets, parts, supplies, public address systems, amateur equipment, testers, kits and fluorescent lighting at lowest prices. Huge stocks, bought months ago... ready for shipment the same day your order is received. The Defense Program is making big demands on our industry but because of our advance buying we are able to fill your orders promptly and efficiently.

BURSTEIN-APPLEBEE COMPANY
1012-14 McGEE, KANSAS CITY, MO.

RADIO CATALOG NO. 58
164 PAGES
SETS-PARTS
SUPPLIES
FLUORESCENT

Burstein-Applebee Co.

"Lum and Abner" BIG PRIZE CONTEST

54 wonderful prizes—\$100 U.S. Defense Bond, 7-Tube All-Wave Radio, Set of Aviation Books, Woodworking Lathe, Model Gas Engine, Power Scroll Saw, Daisy Air Rifle, and many other prizes valued at \$400.00 given away FREE.

CONTEST OPEN TO ALL
Costs nothing to enter. With a valuable prize. Get Science and Mechanics at your newsdealer today for full details. Or send 15c direct to Science and Mechanics, Dept. A-5, 800 North Clark St., Chicago, for a copy.

SCIENCE AND MECHANICS
On Sale at All Newsdealers

Index to advertisers

Allied Radio Corp.....	560
American Radio Institute.....	561
Amperite Corp.....	529
Amplifier Co. of America.....	541, 542
Arrow Radio Company.....	536
Theo. Audel & Co.....	553
Burstein-Applebee Co.....	576
Candler System Co.....	561
C. H. Cannon Co.....	575
Capitol Radio Engineering Institute.....	570
Chartered Inst. of America.....	542
Commercial Radio Institute.....	553
Coyne Electrical School.....	558
Data Print Co.....	574
Dodge's Institute.....	575
Guardian Electric Co.....	575
Harrison Radio.....	558
Hudson Specialties Co.....	555
Hygrade Sylvania Corp.....	516
International Resistance Co.....	518
Lancaster, Allwine & Rommel.....	542
Lincoln Engineering School.....	574
Maedel Publishing House.....	576
McGraw Hill Book Company.....	576
Meissner Mfg. Co.....	549
Murdock Mfg. Co.....	Inside Front Cover
National Company.....	572
National Radio Institute.....	513
National Union Radio Corp.....	525
Nelson Company.....	542
New York Institute of Photography.....	570
Peerless Sound & Radio Co.....	567
Polymet Condenser Co.....	529
Popular Homecraft.....	553
Radercraft Publications, Inc.....	543
Radio Corp. of America.....	Inside Back Cover
RCA Manufacturing Company.....	Back Cover
RCA Institutes.....	529
Radolek Company.....	562
Readrite Meter Works.....	560
Schott Co., Walter L.....	541
Science & Mechanics.....	576
Solar Manufacturing Co.....	541
Sprague Products Company.....	527
Sprayberry Academy of Radio.....	561
Supreme Instruments Corp.....	541
Supreme Publications.....	561
Technifax.....	517, 570
Telex Company.....	558
Treasury Department.....	559
Triplet Electrical Instrument Co.....	515
Tri-State College.....	553
University Laboratories.....	542
X.L. Radio Laboratories.....	574

(While every precaution is taken to insure accuracy, we cannot guarantee against the possibility of an occasional change or omission in the preparation of this index.)

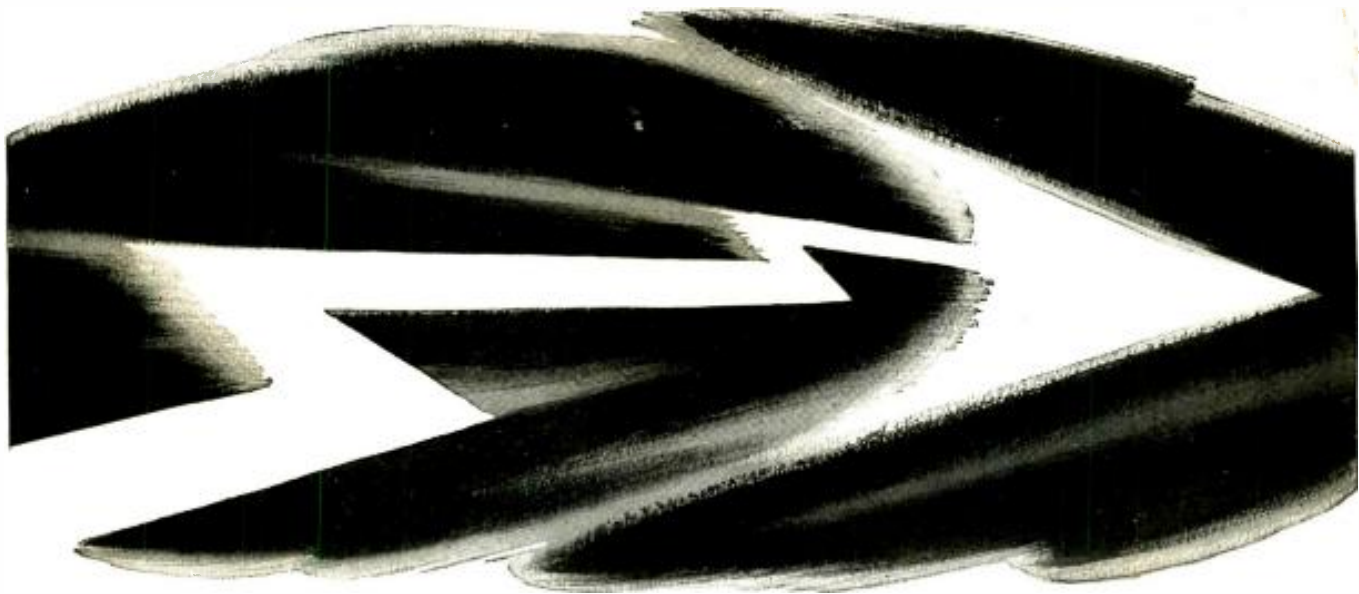

RADIO: SPEARHEAD OF VICTORY!

COMMUNICATION, swift and certain — to coordinate every unit in action — is the first requirement of modern “lightning” warfare. Radio is keyed to the demands of such communication. And, fortunately, America has the greatest radio equipment in the world . . . thanks to research and engineering.

R.C.A. Communications, Inc., transmits and receives messages regularly and reliably to and from more than 45 foreign countries. Equally efficient is the ship-to-shore service of Radiomarine Corporation of America. In the plants of RCA Manufacturing Company, radio equipment for military purposes is coming off the production-

lines in volume—equipment that could not have been constructed in any quantity only a few short years ago! Through the National Broadcasting Company and the Blue Network, radio serves on still another front—keeping Americans unified and informed, through 55 million radio receivers!

On the overseas front, NBC operates two powerful short-wave stations — WRCA and WNBI at Bound Brook, N. J. They help to hurl America’s answer in the “war of words.” Their short-wave beams carrying authentic news, are spearheads of truth through the darkness of war. Today freedom rides America’s radio beams to all the world.



RADIO CORPORATION OF AMERICA

Radio City, New York

The Services of RCA:

RCA Manufacturing Co., Inc. • R.C.A. Communications, Inc. • Radiomarine Corporation of America
RCA Laboratories • National Broadcasting Co., Inc. • Blue Network Co., Inc. • RCA Institutes, Inc.



Tanks get there the hard way

...and RCA Metal Tubes go with them!

You'll find RCA Metal Tubes in the transmitters and receivers of American tanks, British tanks, Russian tanks! For metal tubes afford greater ruggedness under shock and vibration—the positive pin-contact, the self-shielding and compactness—that have helped make Allied military radio equipment the finest in the world.

RCA is now turning out metal-envelope tubes at the fastest pace

in history—for radio equipment in tanks accounts for only part of the demand. Metal tubes by the millions are serving on land, at sea and in the air...meeting the rigid requirements of the armed services. Wherever radio reception must be most reliable—wherever

the going is hardest—you'll find that "metal" means *modern!*

With vast emergency demands by no means unusual today, you may find difficulty in securing metal tubes. We're doing the best we can—we're doing more than ever before—but some delays and shortages may be unavoidable. For, obviously, war equipment comes first . . . and war equipment needs *metal* tubes!



METAL TUBES

ADV Plans, LLC

Copyright Notice:

The entire contents of this CD/DVD are copyright 2014 by ADV Plans, LLC. All Rights Reserved.

Reproduction or distribution of this disk, either free or for a fee is strictly prohibited. We actively monitor and remove listings on eBay thru Vero.

You are free to copy or use individual images in your own projects, magazines, brochures or other school projects.

Only the sellers listed here are authorized distributors of this collection:
www.theclassicarchives.com/authorizedsuppliers

Please view our other products at
www.theclassicarchives.com,
or our ebay stores:

[TheClassicArchives](#)
[ADVPlans](#)
[SuperShedPlans](#)

